

Data sheet

Part number : DRD1204W-TR

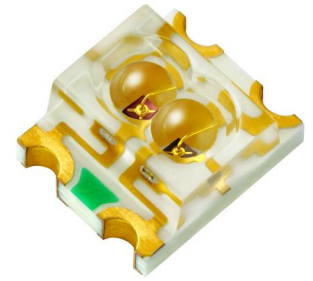

Package	Bi-color emitting LED (Red / Yellow Green) Outer dimension: 3.0 x 2.5 x 1.5mm (L x W x H)
Product features	<ul style="list-style-type: none">•Lead-free soldering compatible•RoHS2 compliant

Recommended applications

- Light source for various indicator, switch etc.

Outline dimensions

DRD1204W-TR

Unit : mm
 Weight : 0.013g
 Tolerance : ±0.2

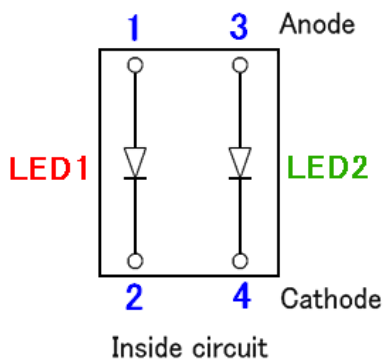
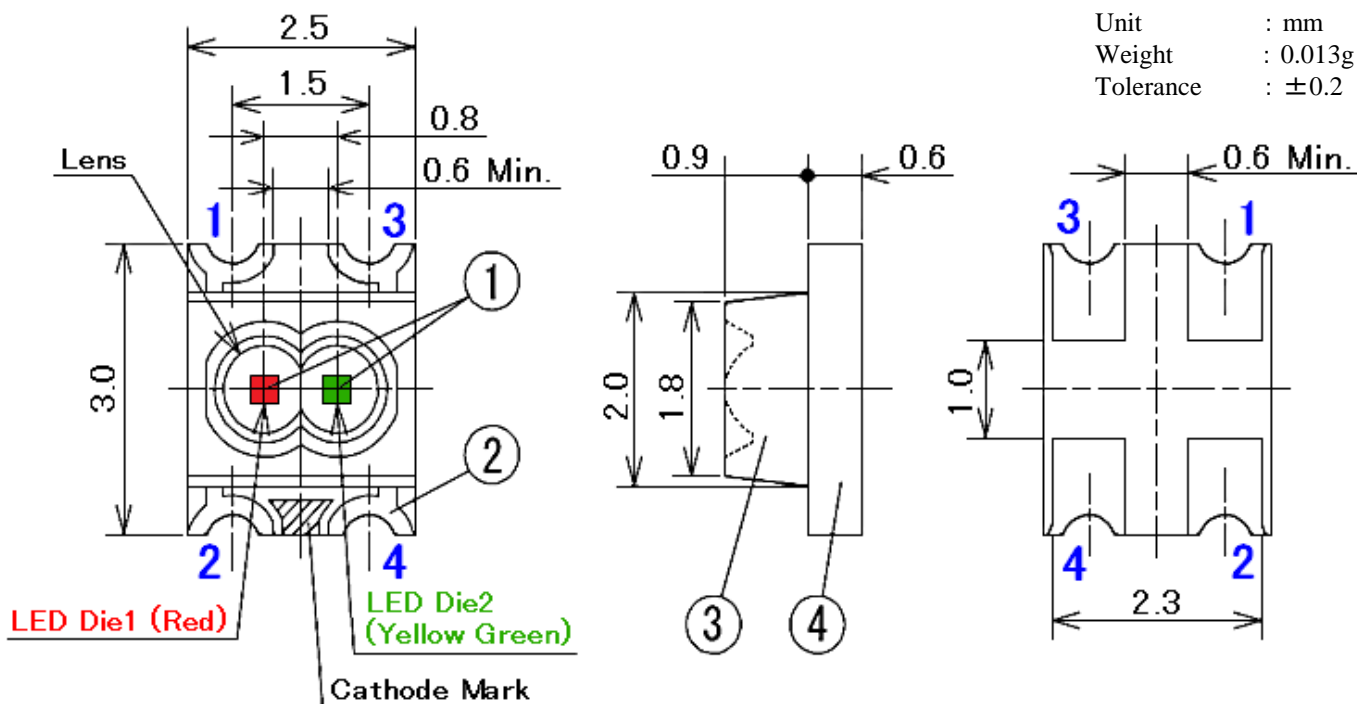

No.	Item	Material	Qty.
①	LED Die	AlGaInP	2
②	Electrode	Copper (Au Plating)	4
③	Mold Resin	Epoxy Resin	1
④	PCB	Glass fabrics	1

Recommended Soldering Pattern

Unit : mm

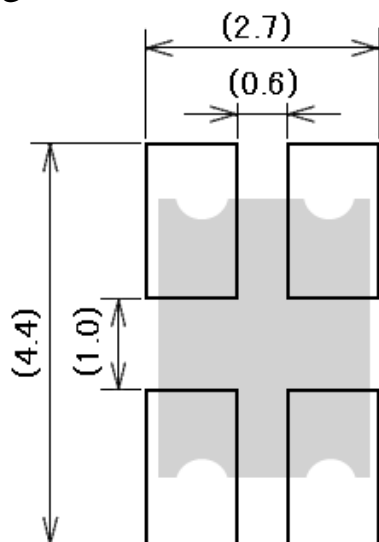

Specifications

DRD1204W-TR

【 Product Overview 】

ITEM	LED Die 1	LED Die 2
DIE MATERIAL	AlGaInP	
EMITTING COLOR	RED	YELLOW-GREEN
RESIN COLOR 【EMITTING AREA】	WATER CLEAR	

【 Absolute Maximum Ratings 】

ITEM	SYMBOL	MAXIMUM RATINGS		UNITS
		LED Die(1)	LED Die(2)	
Power Dissipation	P_d	78		mW
Forward Current	I_F	30		mA
Repetitive Peak Forward Current "1ms, 1/20duty"	I_{FRM}	100		mA
I_F Derate Linearly from "25°C"	ΔI_F	0.43		mA/°C
I_{FRM} Derate Linearly from "25°C"	ΔI_{FRM}	1.33		mA/°C
Reverse Voltage	V_R	5		V
Operating Temperature	T_{opr}	-40 to +85		°C
Storage Temperature	T_{stg}	-40 to +100		°C
Soldering Temperature "Reflow Soldering"	T_{sld}	260°C MAX		

(Ta=25°C)

Notes 1

Notes 1

Notes 2

Notes

1. Each value described on a list is rating at the time of the single color lighting.

The absolutely maximum rating in the simultaneous lighting, the values should be applied 50% Max. of each values.

2. Please refer to page 9, Soldering Conditions.

Specifications

DRD1204W-TR

【 Electro and Optical Characteristics 】

LED Die(1)

(Ta=25°C)

ITEM	SYMBOL	CONDITIONS	MIN.	TYP.	MAX.	UNITS
Forward Voltage	V_F	$I_F = 20\text{mA}$	-	2.0	2.4	V
Reverse Current	I_R	$V_R = 5\text{V}$	-	-	100	μA
Luminous Intensity	I_V	$I_F = 20\text{mA}$	100	-	340	mcd
Peak Wavelength	λ_p	$I_F = 20\text{mA}$	-	635	-	nm
Dominant Wavelength	λ_d	$I_F = 20\text{mA}$	621	626	634	nm
Spectral Line Half Width	$\Delta\lambda$	$I_F = 20\text{mA}$	-	15	-	nm

LED Die(2)

(Ta=25°C)

ITEM	SYMBOL	CONDITIONS	MIN.	TYP.	MAX.	UNITS
Forward Voltage	V_F	$I_F = 20\text{mA}$	-	2.0	2.4	V
Reverse Current	I_R	$V_R = 5\text{V}$	-	-	100	μA
Luminous Intensity	I_V	$I_F = 20\text{mA}$	70	-	240	mcd
Peak Wavelength	λ_p	$I_F = 20\text{mA}$	-	575	-	nm
Dominant Wavelength	λ_d	$I_F = 20\text{mA}$	566	572	578	nm
Spectral Line Half Width	$\Delta\lambda$	$I_F = 20\text{mA}$	-	15	-	nm

Notes

Above the table of Luminous Intensity (I_V) values and Dominant wavelength (λ_d) values are the setup value of the selection machine. 【Tolerance : $I_V \dots \pm 10\%$, $\lambda_d \dots \pm 2\text{nm}$ 】

Specifications

DRD1204W-TR

【 Sorting For Luminous Intensity and Dominant Wavelength 】

LED's shall be sorted out into the following ranks of Luminous Intensity and Dominant Wavelength.

Luminous Intensity (I_v) Rank

Rank	I_v (mcd)				CONDITIONS
	LED Chip 1 (Red)		LED Chip 2 (Yellow-Green)		
	MIN.	MAX.	MIN.	MAX.	
AA	100	150	70	105	$I_F = 20\text{mA}$ $T_a = 25^\circ\text{C}$
AB			105	160	
AC			160	240	
BA	150	225	70	105	
BB			105	160	
BC			160	240	
CA	225	340	70	105	
CB			105	160	
CC			160	240	

Dominant wavelength (λ_d) Rank LED 2 (Yellow-Green)
--

Rank	λ_d (nm)		CONDITIONS
	MIN.	MAX.	
A	566	570	$I_F = 20\text{mA}$ $T_a = 25^\circ\text{C}$
B	570	574	
C	574	578	

Notes

Above the table of Luminous Intensity (I_v) values and Dominant wavelength (λ_d) values are the setup value of the selection machine. 【Tolerance : $I_v \dots \pm 10\%$ 、 $\lambda_d \dots \pm 2\text{nm}$ 】

Technical Data

DRD1204W-TR

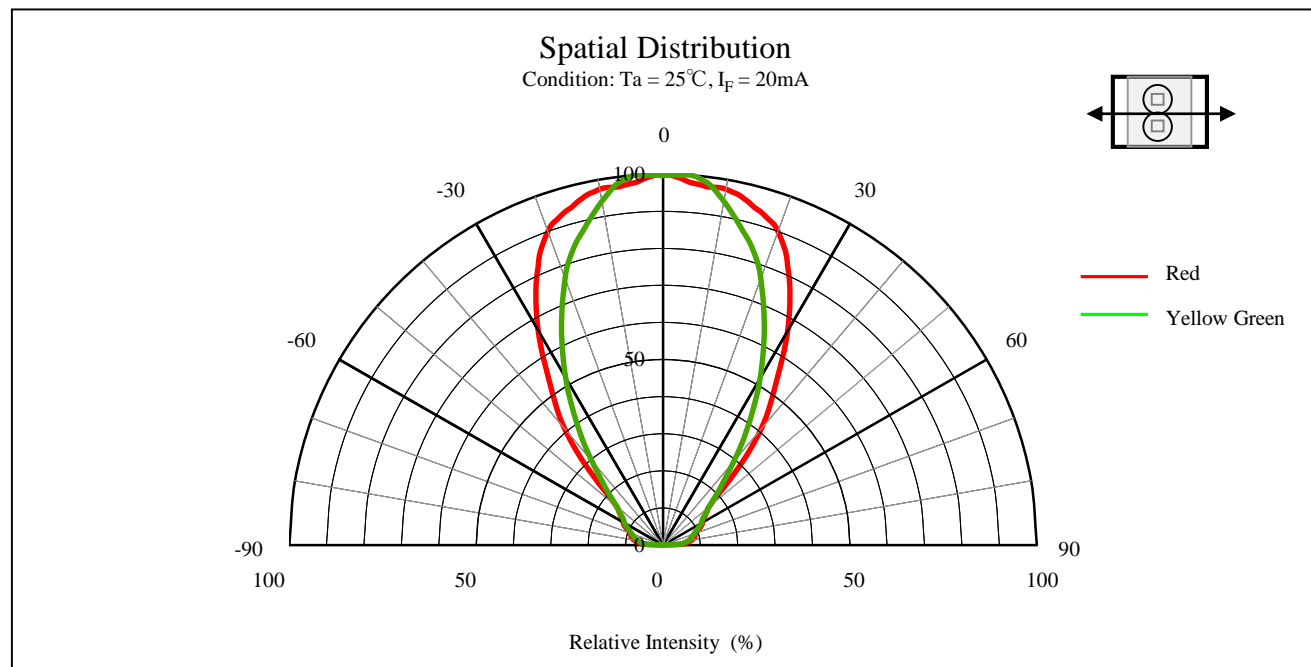
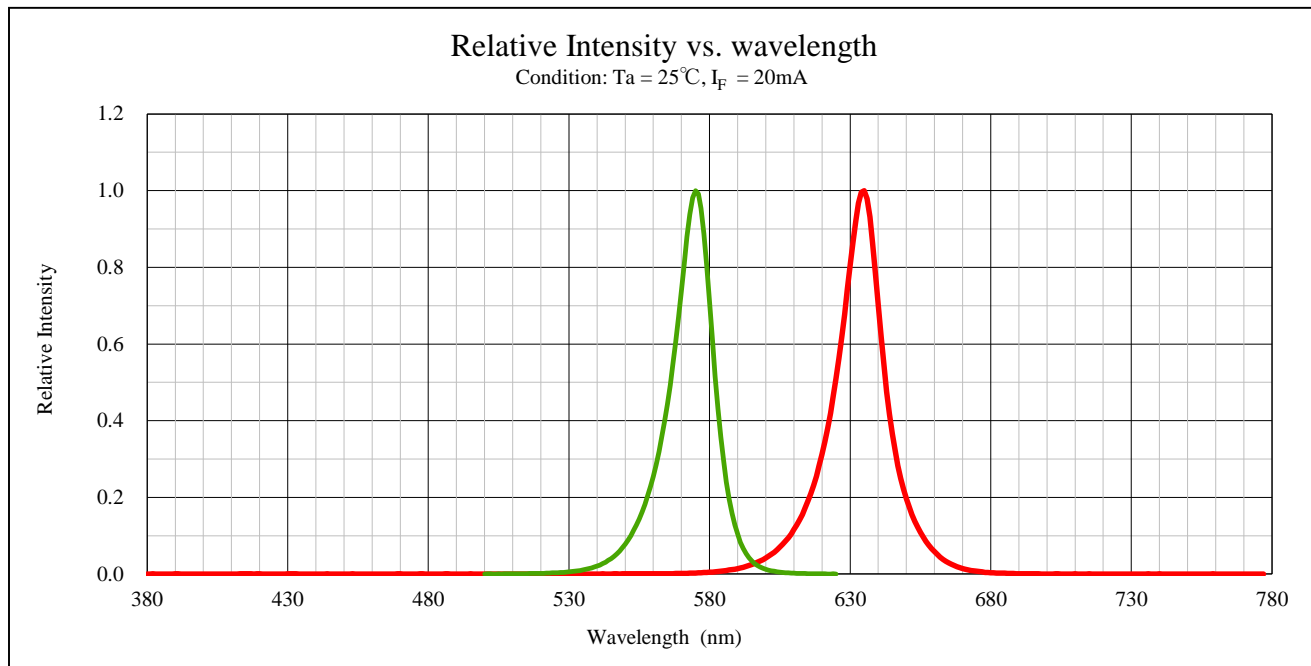

Technical Data

DRD1204W-TR

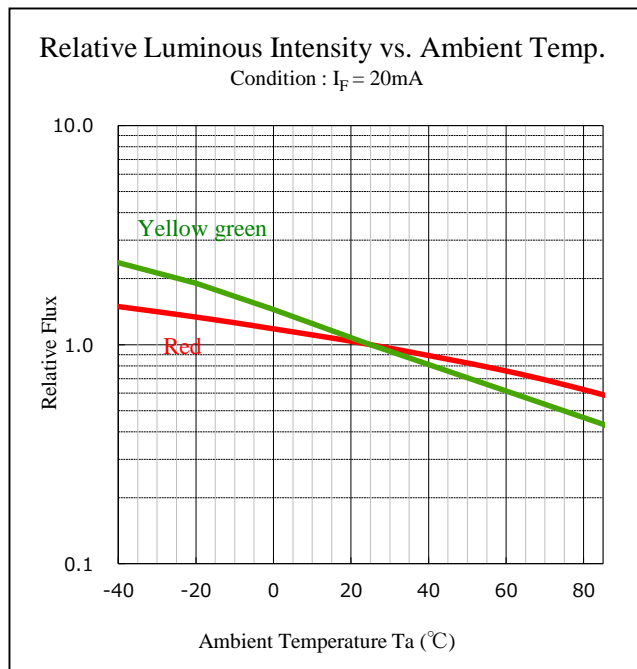
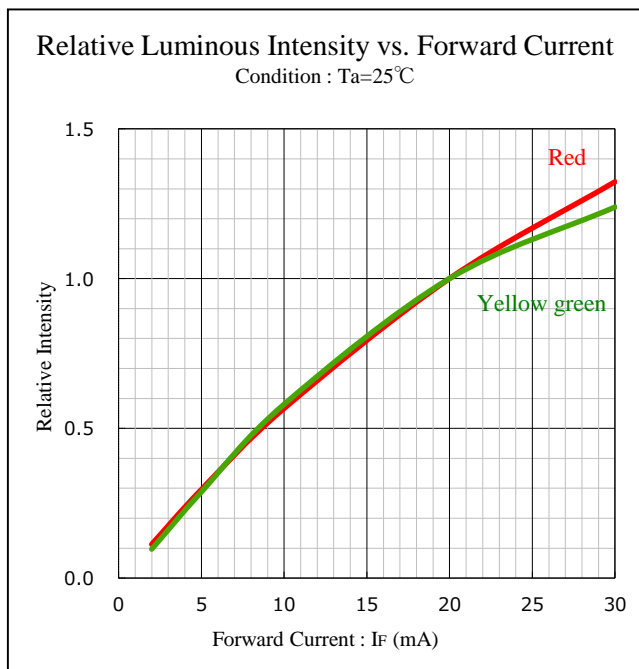
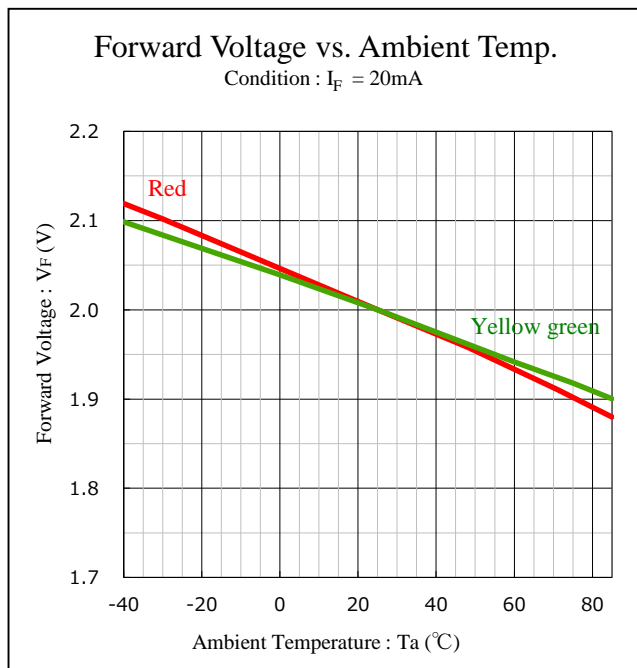
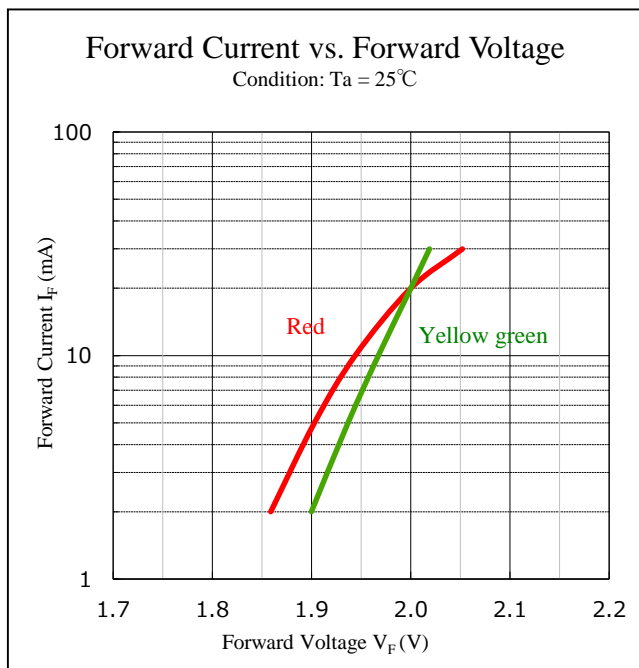

Technical Data

DRD1204W-TR

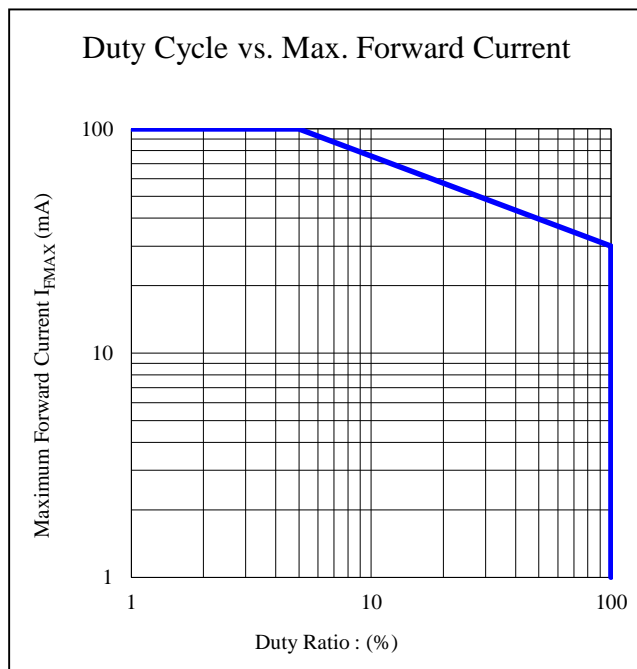
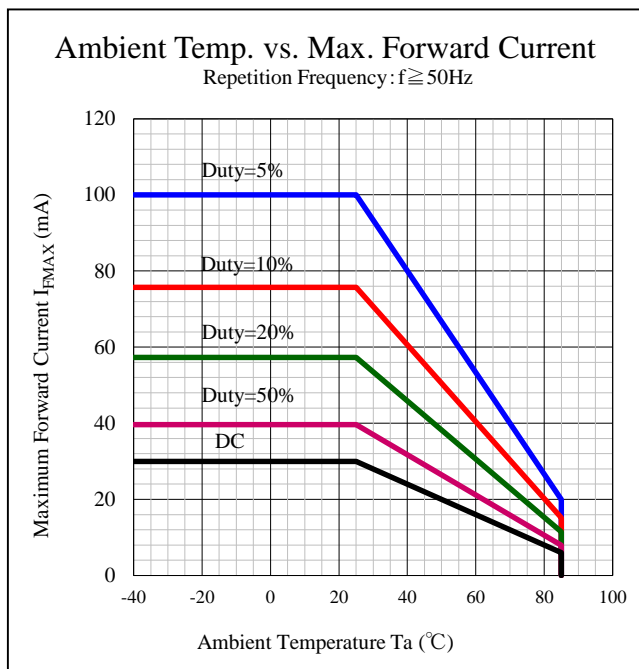
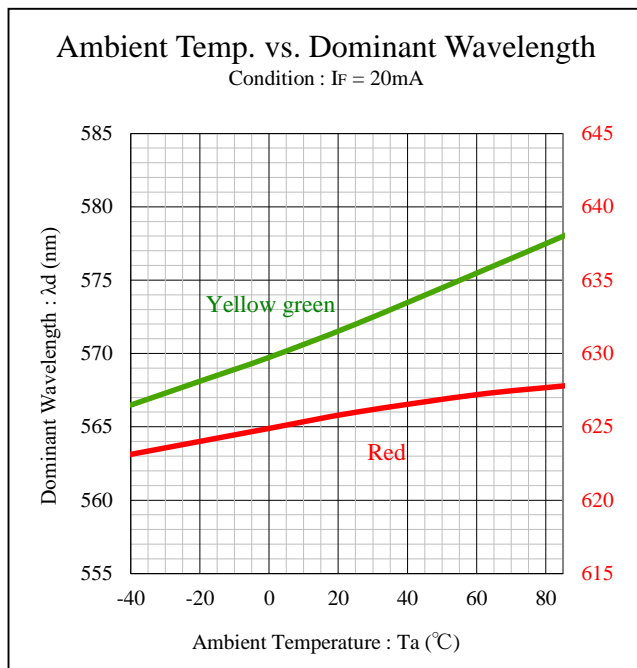
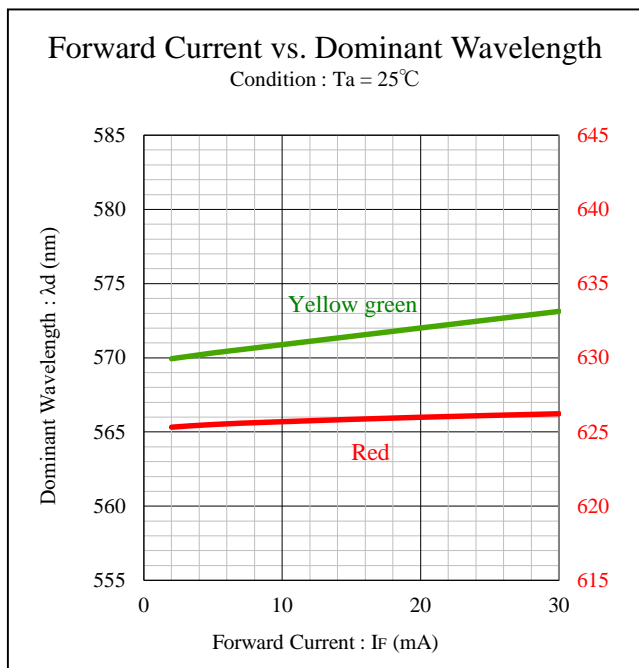

Soldering condition

DRD1204W-TR

【Soldering Precaution】

(acc.to EIAJ-4701/300)

- Heat stress during soldering will influence the reliability of LEDs, however that effect will vary on heating method. Also, if components of varying shape are soldered together, it is recommended to set the soldering pad temperature according to the component most vulnerable to heat (e.g., surface mount LED).
- LED parts including the resin are not stable immediately after soldering (when they are not at room temperature), any mechanical stress may cause damage to the product. Please avoid such stress after soldering, especially stacking of the boards which may cause the boards to warp and any other types of friction with hard materials.
- Recommended temperature profile for the Reflow soldering is listed as the temperature of the resin surface. Temperature distribution varies on heating method, PCB material, other components in the assembly, and mounting density.
Typically, when FR-4 PCB is mounted with one LED and heated via far infrared and hot air, the difference in temperature between PCB and LED resin will be around 5 to 10°C.
Please do not repeat the heating process in Reflow process more than twice.

【Recommended reflow soldering condition】

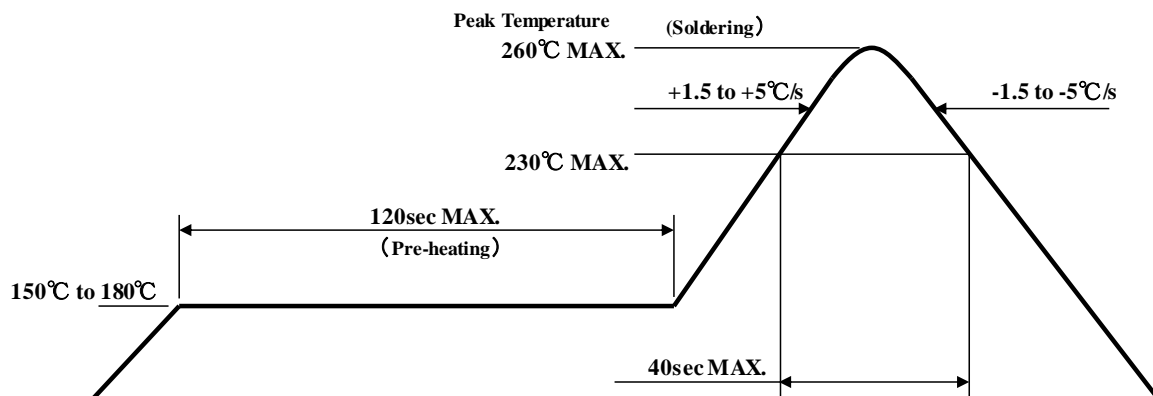

- Note 1 Temperature Profile for the reflow should be set to the surface temperature of resin which is on the top of LED. This should be the maximum temperature for soldering. Lowering the heating temperature and decreasing heating time is very effective in achieving higher reliability.
- Note 2 The reflow soldering process should be done up to twice (2 times Max). When second process is performed, interval between first and second process should be as short as possible to prevent absorption of moisture to resin of LED. The second soldering process should not be done until LEDs have returned to room temperature (by nature-cooling) after first soldering process.

Soldering condition

DRD1204W-TR

4. If soldering manually, Stanley recommends using a soldering iron equipped with temperature control. During the actual soldering process, make sure that the soldering iron never touches the LED itself, and prevent the LED's electrode heating temperature from reaching above the heating temperature of the solder pad. All repairs must be performed only once in the same spot; please avoid reusing components.
5. During soldering process, immediately after iron tip is cleaned please make sure that the soldering iron reaches the appropriate temperature before using. Also, please avoid applying any types of pressure to the soldered components before the solder has cooled down and hardened, as it may deteriorate solder performance and solder quality.

【Recommended manual soldering condition】

Temperature of iron tip	350°C Max.
Soldering duration, time	3sec.Max.,1 time

6. When using adhesive material for temporary fixing, thermosetting resin or Ultraviolet radiation (UV) setting resin with heat is recommended.
《Curing conditions, Temperature:150°CMax./Time:120sec.Max.》
7. Flow soldering (dip soldering) is not recommended for this product.
8. Isopropyl alcohol is recommended for cleaning. Some chemicals, including Freon substitute detergents, might corrode the lens or the casing surface, which might cause discoloration, clouding, cracks and so on. Please review the reference chart below before cleaning. If water is used to clean (including the final cleaning process), please use pure water (not tap water), and completely dry the LED before using. Ultrasonic cleaning is not recommended.

Cleaning agents	Recommended / Not recommended
Isopropyl alcohol	✓ Recommended
Ethyl alcohol	✓ Recommended
Pure water	✓ Recommended
Trichloroethylene	x Not recommended
Chloroethene	x Not recommended
Acetone	x Not recommended
Thinner	x Not recommended

Handling precautions

DRD1204W-TR

【Other Precautions】

1. The products are designed to achieve higher performance reliability, however, they can be influenced by usage conditions.
2. Absolute maximum ratings are set to prevent LED products from failing due to excess stress (temperature, current, voltage, etc.). These ratings must never be overrun even for a moment.
3. To achieve the highest performance reliability, it is necessary to take into account, factors such as forward voltage adjusted to the usage temperature condition, derating of the power consumption, and other variable factors.
4. Please insert Straight Protective Resistors into the circuit in order to stabilize LED operation and to prevent the device from igniting due to excess current.
5. Please check the actual performance in the assembly because the Specification Sheets are described for LED device only.
6. Please refrain from looking directly at the light source of LED at high output, as it may harm your vision.
7. The products are designed to operate without failure in recommended usage conditions. However, please take the necessary precautions to prevent fire, injury, and other damages should any malfunction or failure arise.
8. The products are manufactured to be used for ordinary electronic equipment. Please contact our sales staff beforehand when exceptional quality and reliability are required, and the failure or malfunction of the products might directly jeopardize life or health (such as for airplanes, aerospace, transport equipment, medical applications, nuclear reactor control systems and so on).
9. When there is a process of supersonic wave welding etc. after mounting the product, there is a possibility of affecting on the reliability of junction part in package (junction part of die bonding and wire bonding). Please use after affirming beforehand there is no problem.
10. The formal specification sheets shall be valid only by exchange of documents by both parties.

Handling precautions

DRD1204W-TR

This products are baked (moisture removal) before packaging, and are shipped in moisture-proof packaging (as shown below) to minimize moisture absorption during transportation.

However, in regards to storing the products, the use of dry-box under the following conditions is recommended. Moisture-proof bag as the packaging is made of anti-static material but packaging box is not.

【Recommended Storage Condition / Products Warranty Period】

Temperature	+5~30°C
Humidity	Under 70%

In the case of the package unopened , 6 months under 【 Recommended Storage Condition 】.

Please avoid rapid transition from low temp. condition to high temp. condition and storage in corroding and dusty environment.

【Time elapsed after Package Opening】

The package should not be opened until immediately prior to its use, and please keep the time frame between package opening and soldering which is **【maximum 72 h】**. If the device needs to be soldered twice, both soldering must be completed within 72h.

If any components should remain after their use, please seal the package and store them under the conditions Described in the 【 Recommended Storage Condition 】.

The product must be required to perform baking process (moisture removal) for **at least 10h and not exceed for 12h , at 60+/-5 degrees C** if following conditions apply.

1. In the case of color of indicators (those are in the package of desiccant) change or lose its blue color.
2. In the case of time is passed for 72h after the package is opened once.

Please backing process must be performed after putting out from package.

Baking may be performed in the tape-reel form, however if it is performed with the reel stacked over one another, it may cause deformation of the reels and taping materials, which may cause problems during production. Please make sure that the product has cooled to normal temperature after performing the baking process. Provided that, baking process shall be 2 times MAX.

Packaging specifications

DRD1204W-TR

【Moisture-proof Packaging Specification】

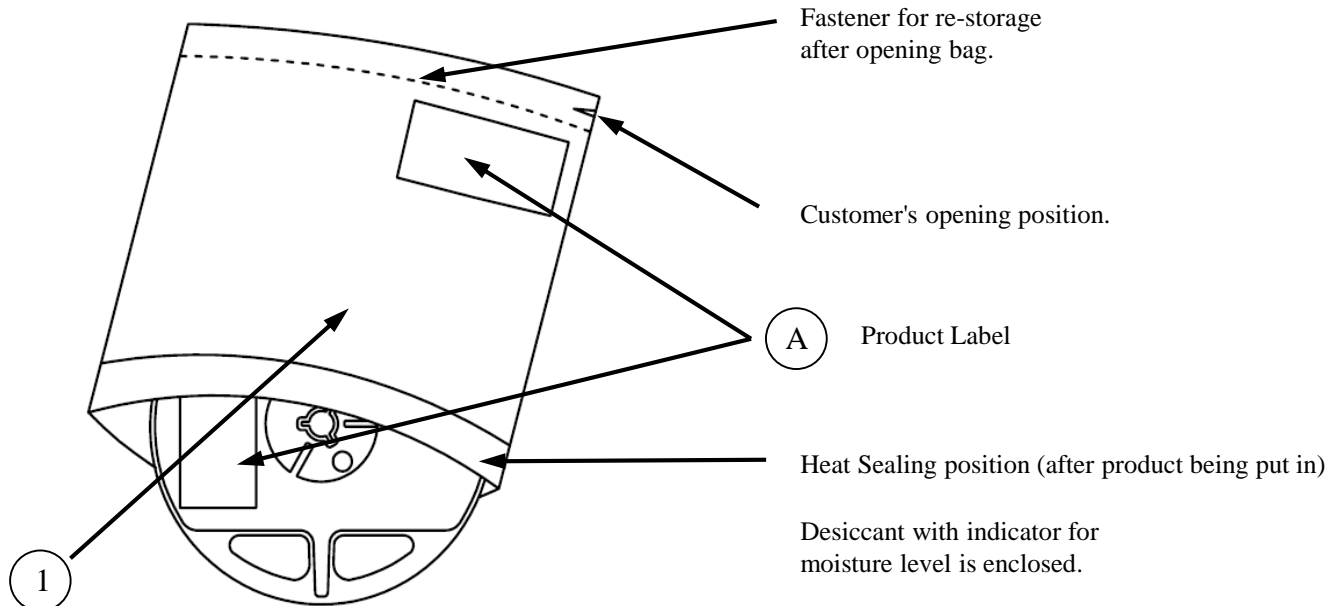

NO.	PART NAME	MATERIALS	REMARKS
①	Moisture-proof bag with Aluminum layer	PET+Al+PE	with ESD protection

【Flow Chart-package Opening to Mounting】

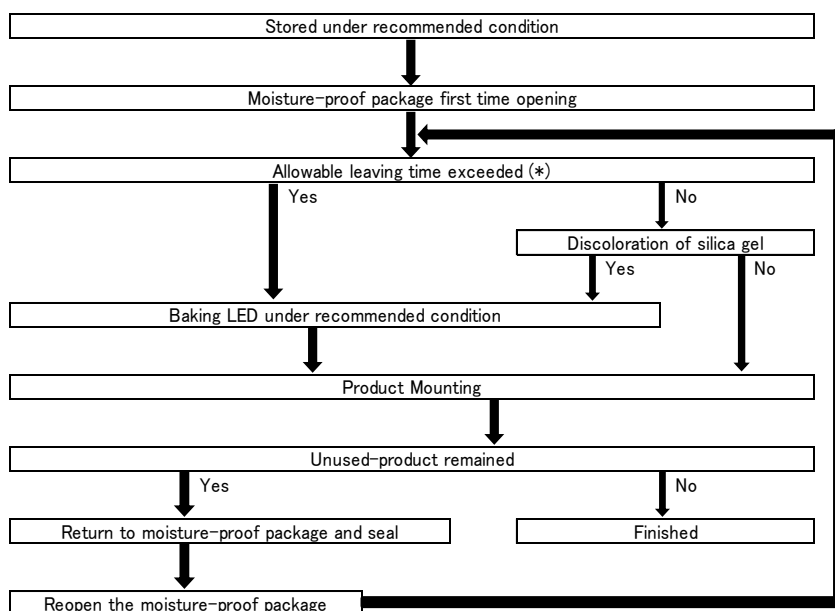

Allowable leaving time means the maximum allowable leaving time after opening package, which depends on each LED type. The allowable leaving time should be calculated from the first opening of package to the time when soldering process is finished. When judging if the allowable leaving time has exceeded or not, please subtract the soldering time. The allowable leaving time after reopening should be calculated from the first opening of package, or from the time when baking process is finished.

Packaging specifications

DRD1204W-TR

【Packing box】

(RoHS2 / ELV Compliant)

Box TYPE	Outline dimension L × W × H (mm)	Capacity of the box
Type A	280 × 265 × 45	3 reel
Type B	310 × 235 × 265	15 reel
Type C	440 × 310 × 265	30 reel

The above measure is all the reference value.

The box is selected out of the above table by shipping quantity.

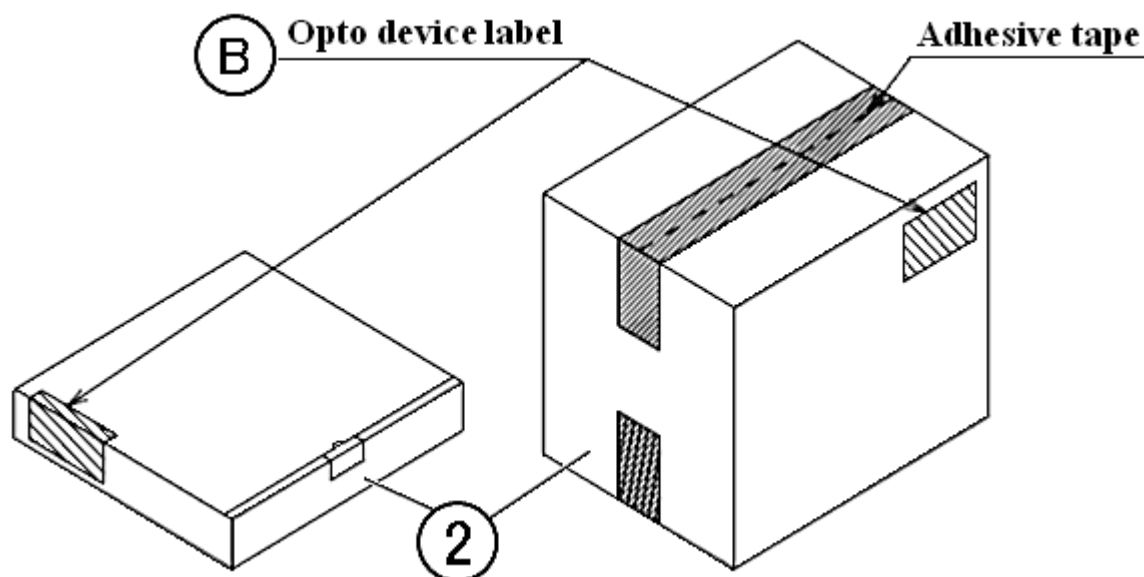

Type A

Material / box : Cardboard C5BF

Type B,C

Material / box : Cardboard K5AF
Partition : Cardboard K5BF

NO.	PART NAME	MATERIAL	REMARKS
②	Packing Box	Corrugated Cardbord	without ESD protection

Packaging specifications

DRD1204W-TR

(acc.to JIS-X0503(Code-39))

【Label Specification】

A Product label

The diagram shows a rectangular label with the following layout:

- Top header: **STANLEY -STANLEY ELECTRIC CO.,LTD.-**
- Field A: A box containing a barcode.
- Field B: A box containing a barcode.
- Field C: A box containing a code, followed by a closing parenthesis **)**.
- Field D: A box containing a code, followed by **PCS**.
- Field E: A box containing a barcode.
- Field F: A box containing a code, preceded by **Lot No.**.
- Field G: A box containing a barcode.

- A. Parts number
- B. Bar-code for parts number
- C. Parts code (In-house identification code for each parts number)
- D. Packed parts quantity
- E. Bar-Code for packed parts quantity
- F. Lot number & Rank
- (Please refer to Lot Number Notational System for details)
- G. Bar-Code for Lot number & Rank

B Opto device label

The diagram shows a rectangular label with the following layout:

- Top header: **STANLEY OPTO DEVICES**
- Field A: A box containing a code, followed by the Japanese characters **御中**.
- Field B: A box containing a code.
- Field D: A box containing a code.
- Field C: A box containing a code, followed by a closing parenthesis **)**.
- Field E: A box containing a code, followed by **PCS**.
- Field G: A box containing a code.
- Field F: A box containing a code, preceded by **C/NO**.
- Field H: A box containing a barcode.
- Bottom header: **STANLEY ELECTRIC CO.,LTD.**

- A. Customer Name
- B. Parts Type
- C. Parts Code
- D. Parts Number
- E. Packed Parts Quantity
- F. Carton Number
- G. Shipping Date
- H. Bar-Code for In-house identification Number

<Remark> Bar-code font : acc.to Code-39(JIX0503)

Taping and reel specifications

DRD1204W-TR

(acc.to JIS-C0806-03)

【Appearance】

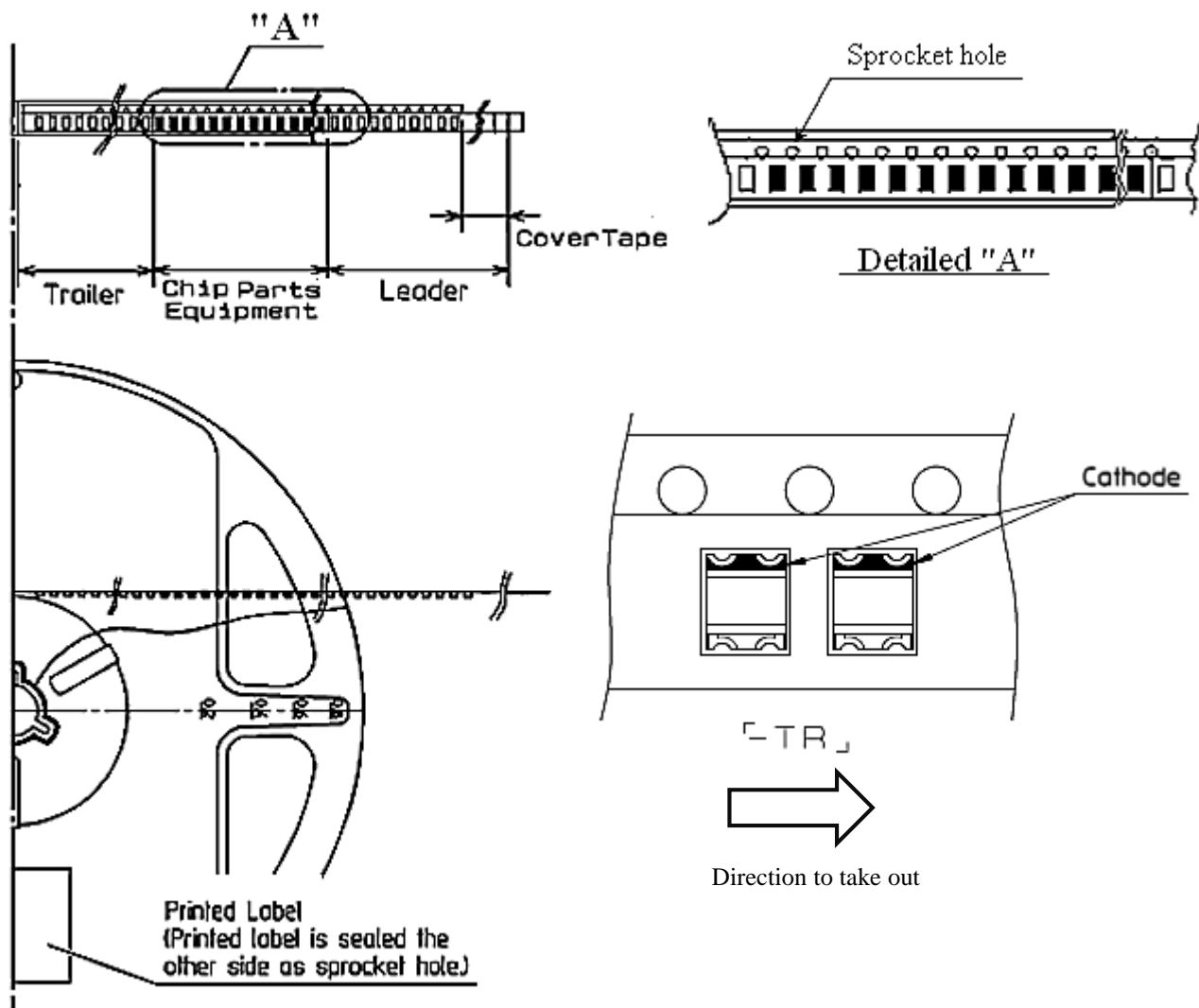

Note

"-TR" means Cathode Side of LEDs should be placed on the sprocket-hole side.

Items		Specifications	Remarks
Leader area	Cover-tape	Cover-tape shall be longer than 200mm without carrier-tape	The end of cover-tape shall be held with adhesive tape.
	Carrier-tape	Empty pocket shall be more than 10 pieces.	Please refer to the above figure for Taping & reel orientation .
Trailer area		Empty pocket shall be more than 15 pieces.	The end of taping shall be inserted into a slit of the hub.

Taping and reel specifications

(acc.to JIS-C0806-03)

DRD1204W-TR

Unit :mm

【Taping Dimensions】

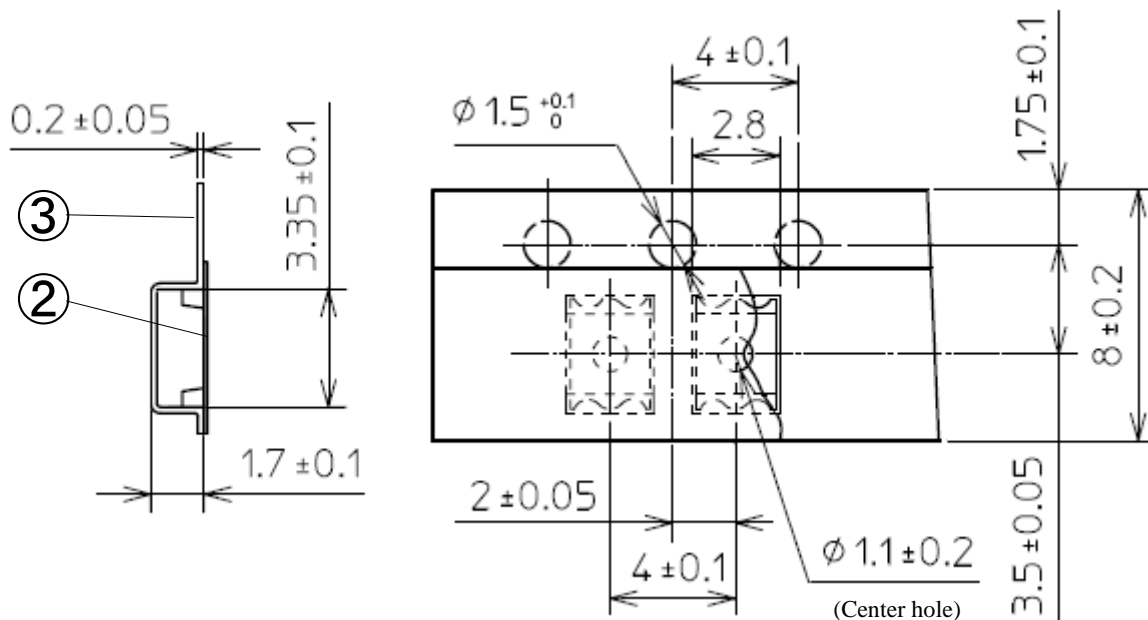

【Reel Dimensions】

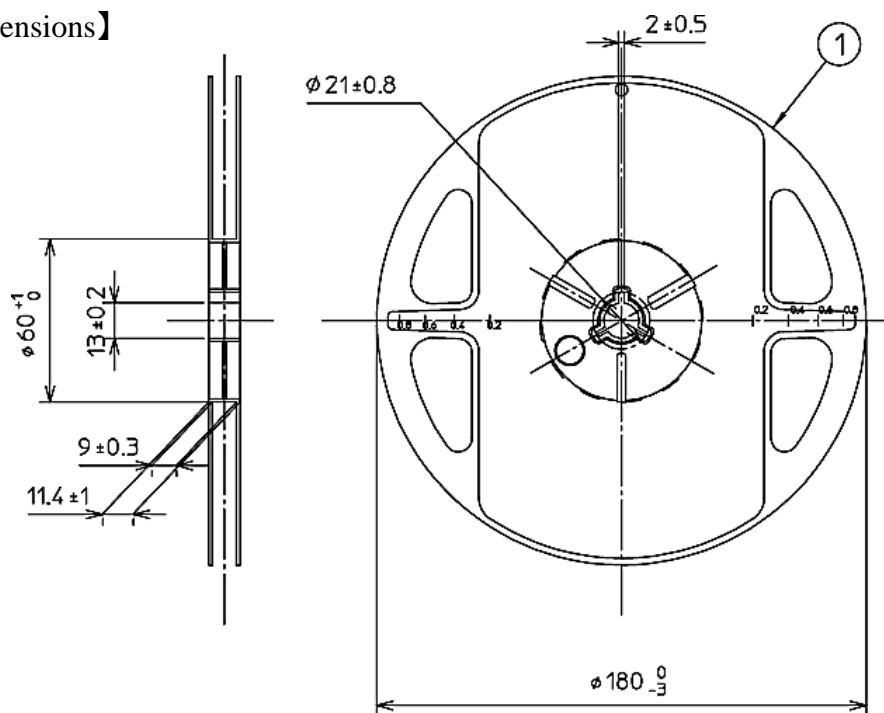

NO.	PART NAME	REMARKS
①	Carrier reel	with ESD protection
②	Cover tape	with ESD protection
③	Carrier tape	with ESD protection

Taping and reel specifications

DRD1204W-TR

(acc.to JIS-C0806-03)

【 Qty. per Reel】

2,500 pcs./ reel

【Mechanical strength】

Cover-tape adhesive strength shall be 0.1~1.0N (An angle between carrier-tape and cover-tape shall be 170 deg.).
Both tapes shall be so sealed that the contained parts will not come out from the tape when it is bent at a radius of 15mm.

【 Others】

- Reversed-orientation, Up-side down placing, side placing and out of spec. parts mix shall not be held.
- The number of empty pockets within a reel is made into 5pcs. or less and no more than 1 connecting empty pockets of taping.

Lot number notational system

DRD1204W-TR

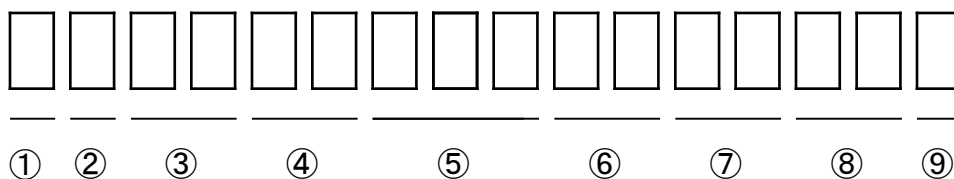

① - 1digit : Production location (mark identify alphabet)

② - 1digit : Production year (The last digit of production year 2024→4, 2025→5, 2026→6, 2027→7 …)

③ - 2digits : Production month (Jan. to Sep. , should be 01,02,03 …)

④ - 2digits : Production date

⑤ - 3digits : Serial number

⑥ - 2digits : Tape and reel following number

⑦ - 2digits : Total power rank.

(If total power rank is 1 digit, "-" shall be dashed on the place for the second digit.

If there is no identified rank, "- -" is used to indicate.)

⑧ - 2digits : Wavelength rank

(If wavelength rank is 1 digit, "-" shall be dashed on the place for the second digit.

If there is no identified rank, "- -" is used to indicate.)

⑨ - 1digit : VF Rank (If rank is not defined, "-" is described.)

Compliance with RoHS2/ELV

DRD1204W-TR

This product is in compliance with RoHS2/ ELV.

Prohibition substance and it's criteria value of RoHS2/ ELV are as follows.

- RoHS2 instruction ... Refer to following 1 to 10.
- ELV instruction ... Refer to following 1 to 4.

No.	Substances	Threshold
1	Lead and its compounds	0.1% (1,000ppm)
2	Mercury and its compounds	0.1% (1,000ppm)
3	Cadmium and its compounds	0.01% (100ppm)
4	Hexavalent chromium compounds	0.1% (1,000ppm)
5	PBB : Polybrominated Biphenyls	0.1% (1,000ppm)
6	PBDE : Polybrominated Biphenyl Ethers	0.1% (1,000ppm)
7	DEHP : Bis (2-ethylhexyl) phthalate	0.1% (1,000ppm)
8	BBP : Butyl benzyl phthalate	0.1% (1,000ppm)
9	DBP : Dibutyl phthalate	0.1% (1,000ppm)
10	DIBP : Diisobutyl phthalate	0.1% (1,000ppm)

Reliability testing result

DRD1204W-TR

1. Reliability testing result

Test Item	Standard	Test Condition	Duration	Failure
Operating Life	EIAJ ED-4701 /100(101)	$T_a = 25^{\circ}\text{C}$, $I_F = 30\text{mA}$	1,000h	0 / 25
High Temperature Storage Life	EIAJ ED-4701 /200(201)	$T_a = 100^{\circ}\text{C}$	1,000h	0 / 25
Low Temperature Storage Life	EIAJ ED-4701 /200(202)	$T_a = -40^{\circ}\text{C}$	1,000h	0 / 25
Wet High Temperature Storage Life	EIAJ ED-4701 /100(101)	$T_a = 60^{\circ}\text{C} \pm 2^{\circ}\text{C}$, $R_h = 90\% \pm 5\%$	1,000h	0 / 25
Thermal Shock	EIAJ ED-4701 /100(105)	$T_a = 100^{\circ}\text{C}$ to -40°C (each 15min)	5 cycles	0 / 25
Resistance to Reflow Soldering	EIAJ ED-4701 /300(301)	Preheating : 150 to 180°C 120s Max. Soldering : 230°C 40s Max. Peak Temperature : 260°C	2times	0 / 25
Vibration, Variable Frequency	EIAJ ED-4701 /400(403)	$98.1\text{m/s}^2(10\text{G})$ $100 \sim 2,000\text{Hz}$ 20min Sweep XYZ direction	2h of each direction	0 / 10

2. Failure criteria

Item	Symbol	Condition	Failure Criteria
Luminous Intensity	I_V	20mA	Testing Min. Value $<$ Standard Min. Value $\times 0.5$
Forward Voltage	V_F	20mA	Testing Max. Value \geq Standard Max. Value $\times 1.2$
Reverse Current	I_R	$V_R = 5\text{V}$	Testing Max. Value \geq Standard Max. Value $\times 2.5$
Cosmetic appearance	-	-	Notable, decollation, deformation and cracking

Special Notice to Customers Using the Products and Technical Information Shown in This Data Sheet

- 1) The technical information shown in the data sheets are limited to the typical characteristics and circuit examples of the referenced products. It does not constitute the warranting of industrial property nor the granting of any license.
- 2) For the purpose of product improvement, the specifications, characteristics and technical data described in the data sheets are subject to change without prior notice. Therefore it is recommended that the most updated specifications be used in your design.
- 3) When using the products described in the data sheets, please adhere to the maximum ratings for operating voltage, heat dissipation characteristics, and other precautions for use. We are not responsible for any damage which may occur if these specifications are exceeded.
- 4) The products that have been described to this catalog are manufactured so that they will be used for the electrical instrument of the benchmark (OA equipment, telecommunications equipment, AV machine, home appliance and measuring instrument).
The application of aircrafts, space borne application, transportation equipment, medical equipment and nuclear power control equipment, etc. needs a high reliability and safety, and the breakdown and the wrong operation might influence the life or the human body. Please consult us beforehand if you plan to use our product for the usages of aircrafts, space borne application, transportation equipment, medical equipment and nuclear power control equipment, etc. except OA equipment, telecommunications equipment, AV machine, home appliance and measuring instrument.
- 5) In order to export the products or technologies described in this data sheet which are under the “Foreign Exchange and Foreign Trade Control Law,” it is necessary to first obtain an export permit from the Japanese government.
- 6) No part of this data sheet may be reprinted or reproduced without prior written permission from Stanley Electric Co., Ltd.
- 7) The most updated edition of this data sheet can be obtained from the address below:
<http://www.stanley-components.com/en/>

Mouser Electronics

Authorized Distributor

Click to View Pricing, Inventory, Delivery & Lifecycle Information:

[Stanley Electric:](#)

[DRD1204W-TR](#)