

UNIT:MM

REVISION INFORMATION

Rev.	Rev. Date	Modified By	Brief Description
A/0	18-07-30	T0730A	NEW DRAWING

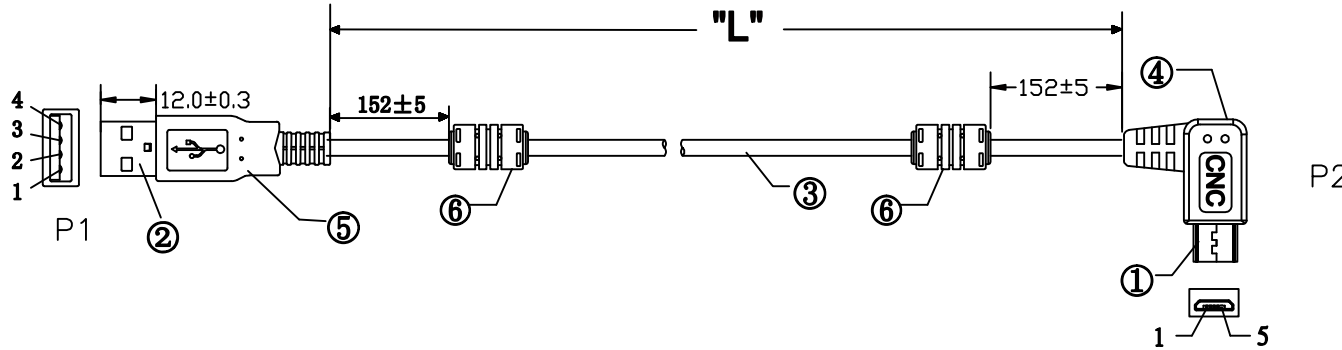

PIN ASSIGNMENT:

P1		P2
1	RED	1
2	WHITE	2
3	GREEN	3
4	BLACK	5
SHELL DRAIN+BRAID		SHELL

Electrical test:

- 100% short, open, miswire test
- Conduct resistance: 2 Ohm(max)
- Insulation resistance: 10Mohm(min)
- dielectric test: DC 300V

CABLE WHITE PRINT

E166160 AWM 2725 80°C 30V  
28AWGX1P+24AWGX2C USB2.0

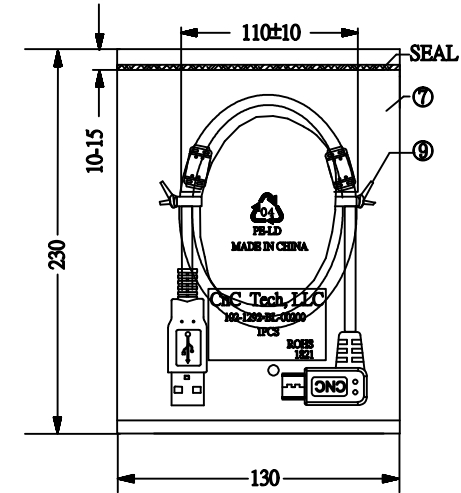

PART NO	WIRE LENGTH "L"	BUYER COLOR	VENDOR COLOR	CUT LENGTH
102-1292-BL-00200	2000±20		BLACK	2070-2080MM

⑨	TIE	2	BLACK L=90mm
⑧	PE BAG	1/10	CLEAR SIZE:280X330X0.05mm PRINT BLACK"MADE IN CHINA"+"10PCS".
⑦	PE BAG	1	CLEAR SIZE:130X230X0.05mm PRINT BLACK"MADE IN CHINA"+"1PC".
⑥	OUT JACKET	18g	BLACK 45P PVC(MOLD NO:CH003)
	FERRITE	2	CORE OD12*5.6*L20
⑤	OUT JACKET	6g	BLACK PVC-40P (MOULD NO:2002-527)
④	OUT JACKET	6g	BLACK PVC-40P (MOULD NO:NM-130 & WM-251)
③	CABLE	1	BLACK USB2.0 UL2725 28#/1P+24#/2C+AEB OD:4.7mm
②	CONN	1set	USB A MALE SHELL:NICKEL PIN:G/F 3PCS TYPE INSULATOR COLOR:WHITE
①	CONN	1	MICRO USB 5P B/M SOLDER TYPE SHELL:NICKEL PIN:G/F INSULATOR COLOR:BLACK

NO.	NAME	QTY	SPECIFICATION
-----	------	-----	---------------

CnC Tech, LLC  
Industrial Cable and Connector Technology

DRAWN BY:	DATE: 2018/07/30	DESCRIPTION: 4C CABLE USB A/M+MICRO 5P
CHECKED BY:	SHEET 1 of 1	ITEM NO. As above
APPROVED BY:	SCALE 1:1	REV. A/0 UNIT: mm