

# TO-3228BC-BF-1

## Surface Mount Device LED

Part Number	Chip		Lens Color
	Material	Source Color	
TO-3228BC-BF-1	InGaN	Blue	Water Clear

### Features

- IC compatible
- Compatible with automatic placement equipment
- Compatible with infrared and vapor phase reflow soldering process
- Top view type
- Pack in 8 mm tape on 7" diameter reel
- RoHS compliant
- Moisture sensitivity Level: level 3

### Dimensions

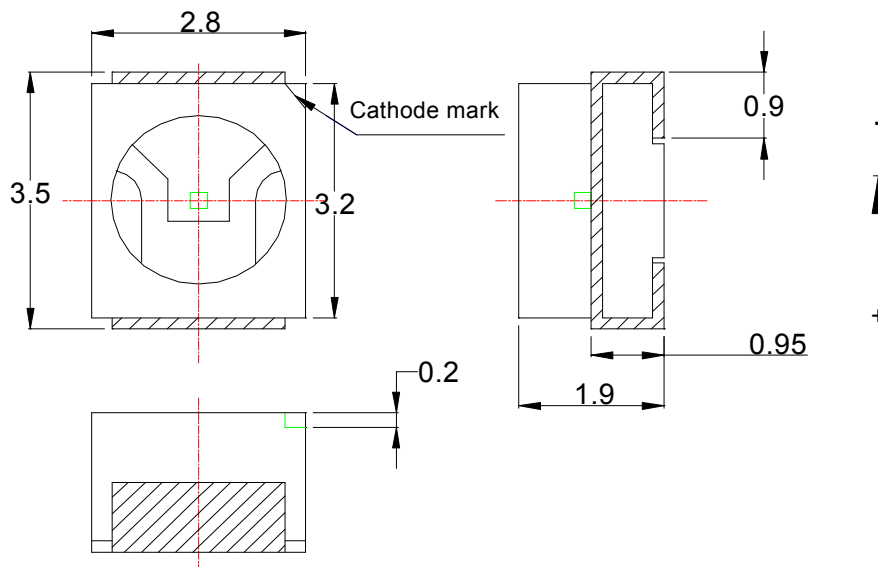

#### Notes:

1. All dimensions are in millimeter.
2. Tolerance is  $\pm 0.1$ mm unless individual mark noted.

### Absolute Maximum Rating @ Ta=25°C

Parameter	Maximum Rating	Unit
Peak Forward Current (1/10 Duty Cycle, 0.1ms Pulse Width)	80	mA
Power Dissipation	105	mW
Continuous Forward Current	25	mA
Reverse Voltage	5	V
Operating Temperature Range	-55°C to +85°C	
Storage Temperature Range	-55°C to +105°C	
IR Reflow Soldering Profile For Lead Free Soldering	260°C	

### Electrical / Optical Characteristic @ Ta=25°C

Parameter	Symbol	Min.	Typ.	Max.	Unit	Test Condition
Luminous Intensity	I <sub>v</sub>	112		321	mcd	I <sub>F</sub> =20mA
Viewing Angle	2θ <sub>1/2</sub>		120		deg	I <sub>F</sub> =20mA
Forward Voltage	V <sub>F</sub>		3.2		V	I <sub>F</sub> =20mA
Dominant Wavelength	λ <sub>d</sub>		468		nm	I <sub>F</sub> =20mA
Spectral Line Half-Width	Δλ		26		nm	I <sub>F</sub> =20mA
Reverse Current	I <sub>R</sub>			10	μA	V <sub>R</sub> =5V

## Bin Code List for Reference

Luminous Intensity		Unit : mcd@20mA
Bin Code	Min	Max
F2	190	247
F3	247	321
F4	321	417

Tolerance of Luminous Intensity on each bin is  $\pm 15\%$

Dominant Wavelength		Unit : nm@20mA
Bin Code	Min	Max
464466	464	466
466468	466	468
468470	468	470
470472	470	472
472474	472	474

Tolerance of Dominant Wavelength on each bin is  $\pm 1\text{nm}$

Forward Voltage		Unit : nm@20mA
Bin Code	Min	Max
V1	2.8	3.0
V2	3.0	3.2
V3	3.2	3.4
V4	3.4	3.6

Tolerance for each Forward Voltage Bin is  $\pm 0.1\text{V}$