

För icke direkt toleranssatta mått gäller toleransklass  
 General tolerances if not otherwise stated

NOM DIM MM		TOL CLASS		
From	To	A	B	C
(1)	6	±0.05	±0.1	±0.2
(6)	30	±0.1	±0.2	±0.5
(30)	100	±0.15	±0.3	±0.8
(100)	300	±0.2	±0.5	±1.2
(300)	1000	±0.3	±0.8	±2

Hål / Holes H13

Skarpa kanter brutna där ej annat anges.  
 No sharp edges unless otherwise specified.

Övriga generella toleranser enligt ritning 4100-4644.  
 Additional general tolerances in accordance with drawing 4100-4644.

Rev	Change order	Change: A = Added W = Was D = Deleted	Date	Sign
5	1014994000	4100-4100 ÄNDRAD/CHANGED	021009	SE
6	1016307000	BILDVY FÖR SKRUV INFÖRD/ PICTURE OF SCREW ADDED	030424	TGW
7	1016252000	4100-4099 ÄNDRAD/CHANGED 4100-0213 A	030505	SE

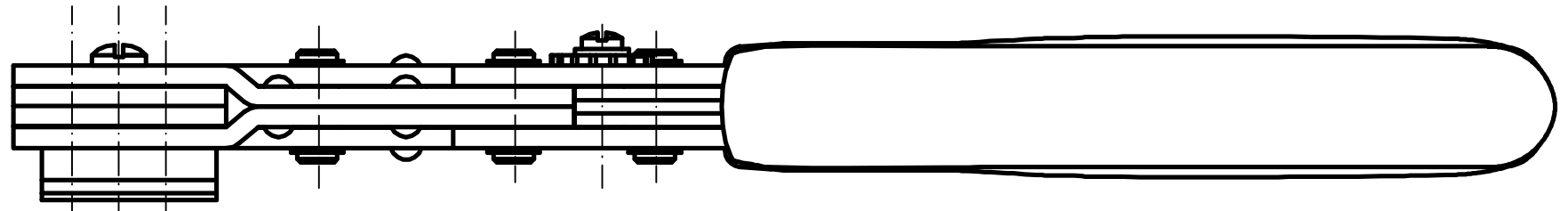

Denna ritning är Pressmaster AB:s egendom. Skyddad av gällande lag.  
 This drawing is the property of Pressmaster AB. Protected in accordance with prevailing law.

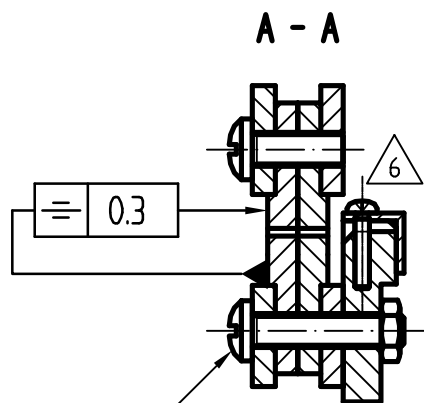

- 4100-0016
- 4100-0152
- 4100-1426 C
- 4100-2382
- 4100-2444

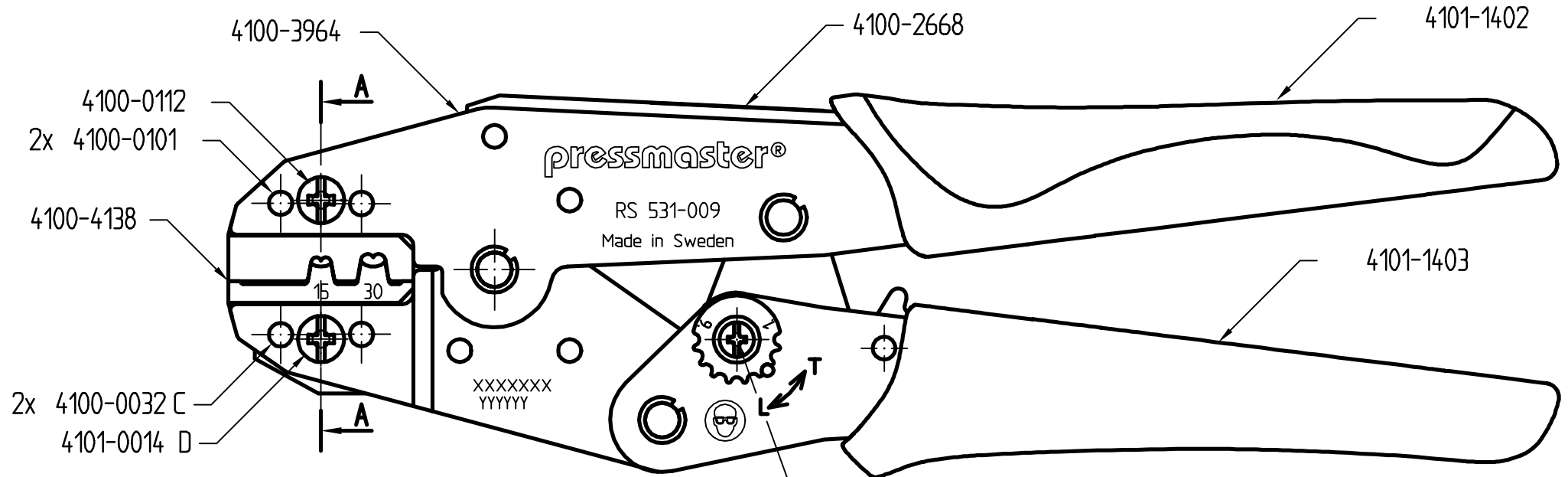

FÖRSPÄNNING / PRELOAD : 200±40 N

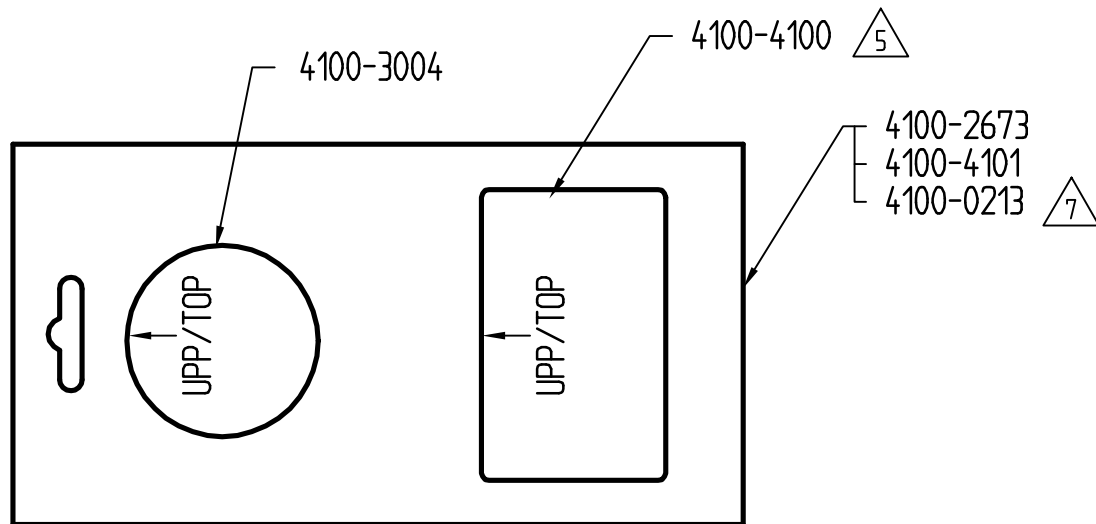

LASERMÄRKT ENLIGT RITNING: 4100-4099  
 LASERMARKED ACCORDING TO DRAWING: 4100-4099

Material		Behandling/Treatment			Status Prel.utc.	
Konstr./Design HL	Ritad/Drawn HL	Datum/Date 9/10/14	Skala/Scale 1:1	Kontr./Checked	Godk./Approved	Anne/Blank
<b>pressmaster®</b>				Benämning/Denomination Krimptång 531-009		Vikt/Weight, gram Art grp 012
REG NR FM13687				CRIMPING TOOL		Ritn nr/Drawing no 43001025 REV 007