

Dec.1.2019 Copyright 2019 HIROSE ELECTRIC CO., LTD. All Rights Reserved.  
In case of consideration for using Automotive equipment / device which demand high reliability, kindly contact our sales window

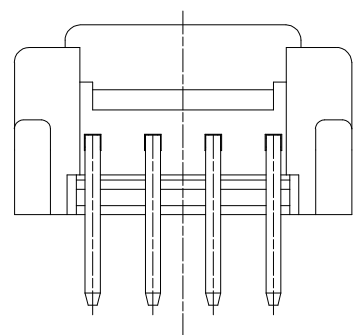

POLARIZATION MARK

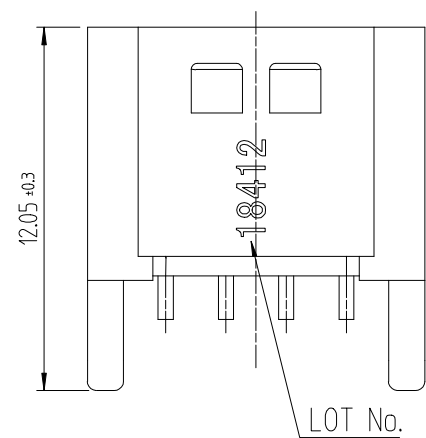
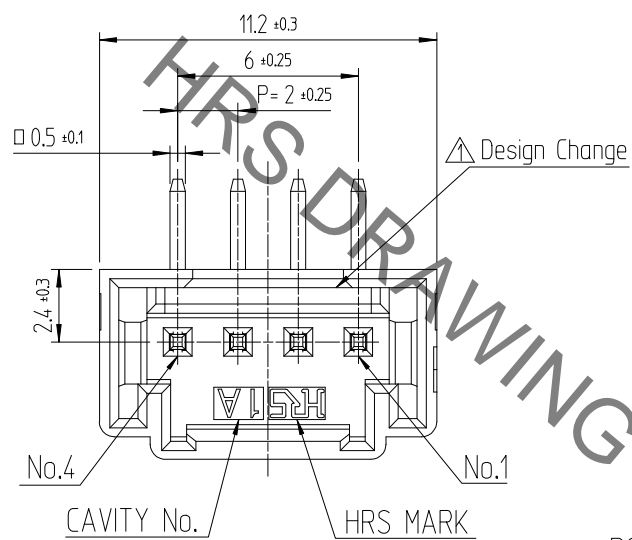
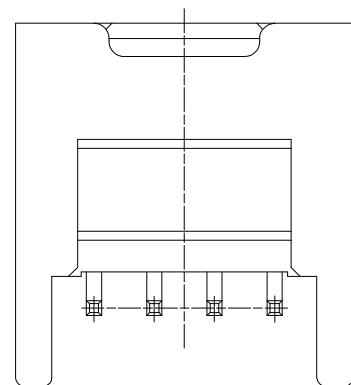
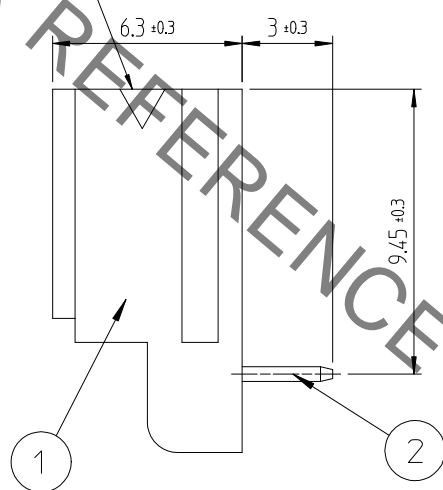

RECOMMENDED LAND PATTERN (FREE)  
(PCB THICKNESS t=1.6mm)

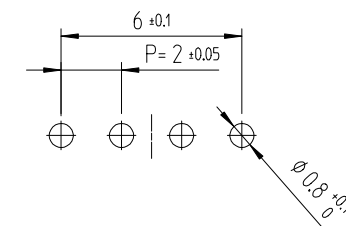

ENGAGEMENT FIGURE (2:1)

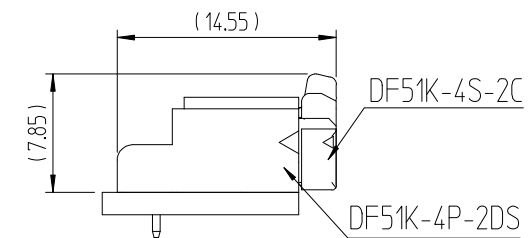
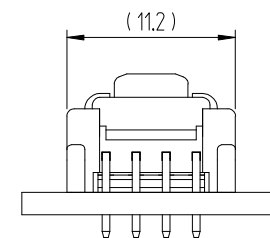

△數 COUNT	訂正事項 DESCRIPTION OF REVISIONS	擔當 B Y	檢圖 CHKD	年月日 DATE	△數 COUNT	訂正事項 DESCRIPTION OF REVISIONS	擔當 B Y	檢圖 CHKD	年月日 DATE
1	RE-6-1150	K.I.Y	L.S.M	18. 07. 04					

NOTE 1. 1TRAY CONTAINS 270PCS.  
2. ( )DIMENSIONS ARE ONLY REFERENCE.

1	PBT	UL94V-0, BLACK	2	BRASS	GOLD PLATING 0.1μm MIN, OVER NICKEL 0.5μm MIN		
NO.	MATERIAL	FINISH,REMARKS	NO.	MATERIAL	FINISH,REMARKS		
CODE NO. (OLD)			DRAWN	DESIGNED	CHECKED	APPROVED	RELEASED
			CHOI 18.03.02 J.S	CHOI 18.03.02 J.S	LIM 18.03.02 S.M	KANG 18.03.02 T.S	
DRAWING NO. EDC3-632473			PART NO. DF51K-4P-2DS (805)				
SCALE 4:1			CODE NO. CL 6652-0061-3-805				
UNITS mm			HIROSE KOREA CO.,LTD.				
						1	1