

Panasonic

PIR Motion Sensor

(((PaPIRs)))

Special Designs from Panasonic that Provide High Sensitivity and Reliability



Motion Sensor

PIR Motion sensors (Passive Infrared or Pyroelectric) from Panasonic for optimal usability and reliability

Panasonic develops and produces PIR Motion sensors, which combine easy integration, high reliability and environment-friendly materials.

The Panasonic PIR Motion sensors abbreviated as PaPIRs, has three series of products, including

- EKMB (WL) with low current consumption
- EKMC (VZ) for general use
- AMN (NaPiOn), the traditional type. Various lenses, digital and analog types are available:

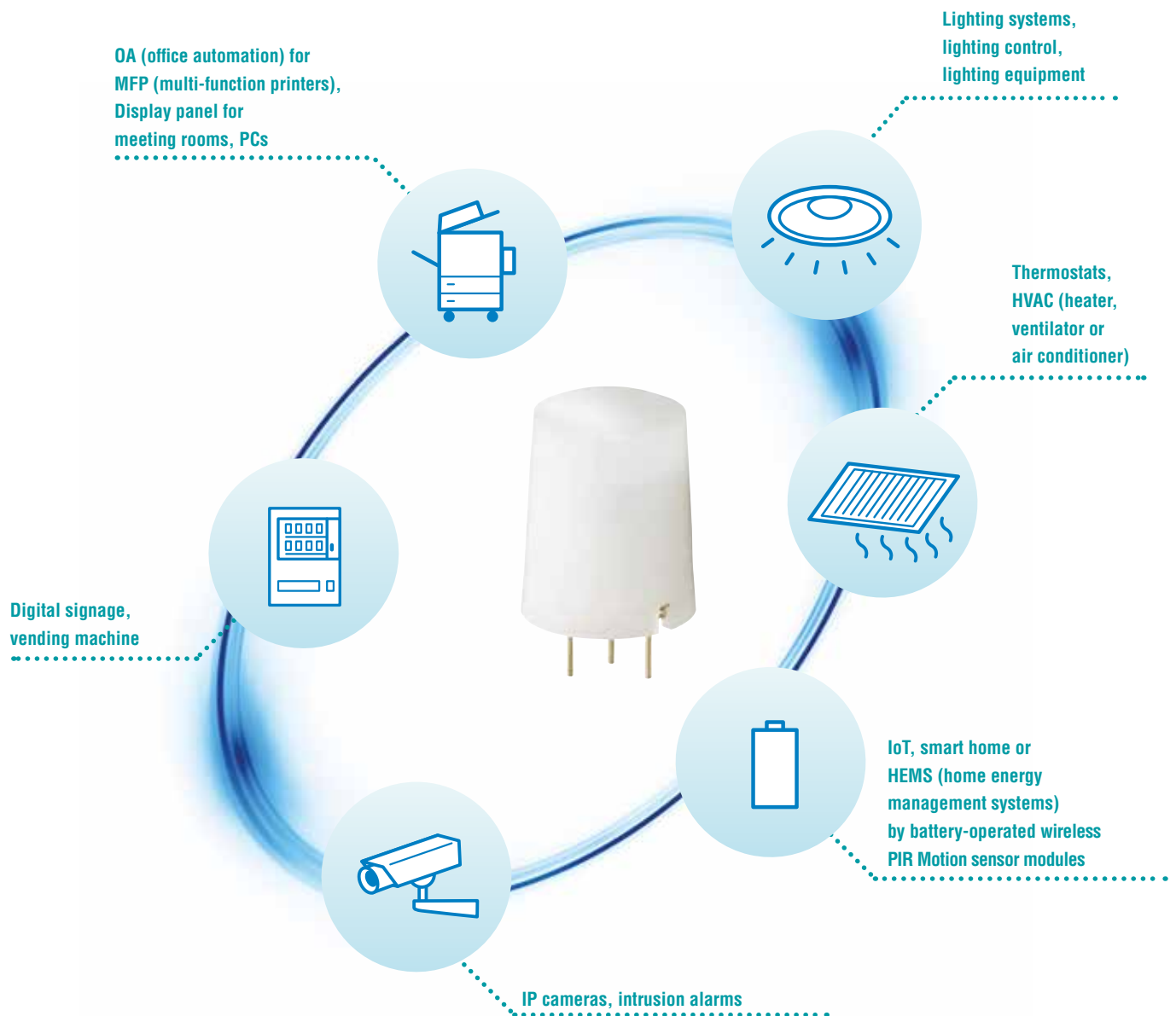

Unique design to satisfy market demand

The PIR Motion sensors from Panasonic offer crucial advantages over conventional PIR Motion sensors.

The unique design concept (explained below) ranges from the production of the pyroelectric sensing devices to the internal signal processing, thus guaranteeing an optimal detection capability and high reliability.

Easy design-in, save design costs by excellent radiation noise resistance

The integrated amplifier /comparator circuit inside a TO-5 metal can (digital type) prevent interferences caused by electromagnetic fields, such as those generated by cell phones and wireless devices. A special differential circuit design is introduced for the EKMB 6μA type for applications where a high noise resistance is required (up to GHz range).

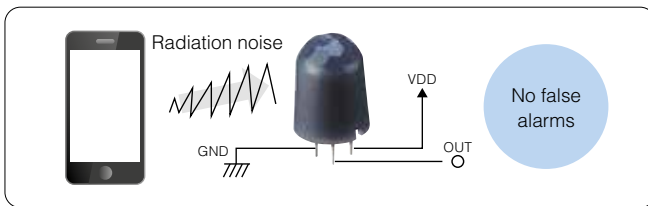
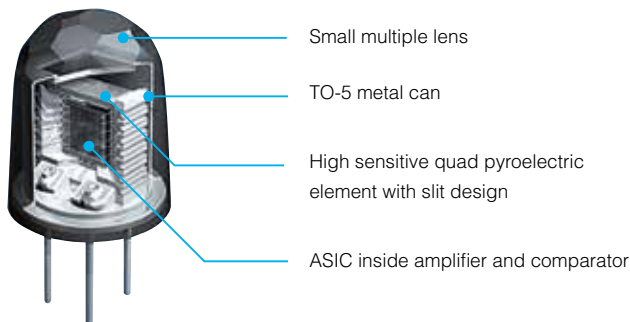

2 times better sensitivity

The sensitivity has been significantly improved thanks to a unique slit design of the pyroelectric elements. The separated sensing areas prevent thermal crosstalk between the single sensing elements. Therefore, reliable detection is possible even if the temperature difference between the background (e.g. floor /wall) and the target object (human) is small. (e.g. $\Delta T = 4 \text{ degC}$)

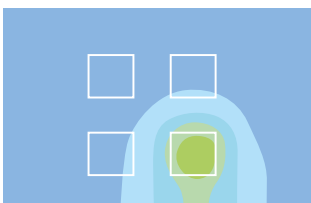

Temperature distribution of conventional pyroelectric sensors without slit

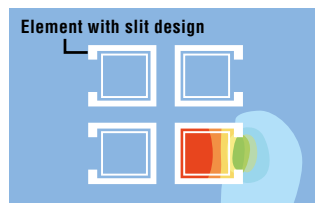

Temperature distribution of Panasonic's pyroelectric infrared Ssensors with slit design

Lead-free pyroelectric element

A ferroelectric LiTaO₃ single lead-free crystal is used as the pyroelectric element for Panasonic PIR Motion sensors. Conventional PIR Motion sensors normally use a ceramic base material (e.g. PZT) for the pyroelectric element, which contains lead in many cases.

Small and fancy lens design

Thanks to the special design of the small pyroelectric elements, it is possible to use a smaller lens size while keeping the same detection area compared to conventional sensors.

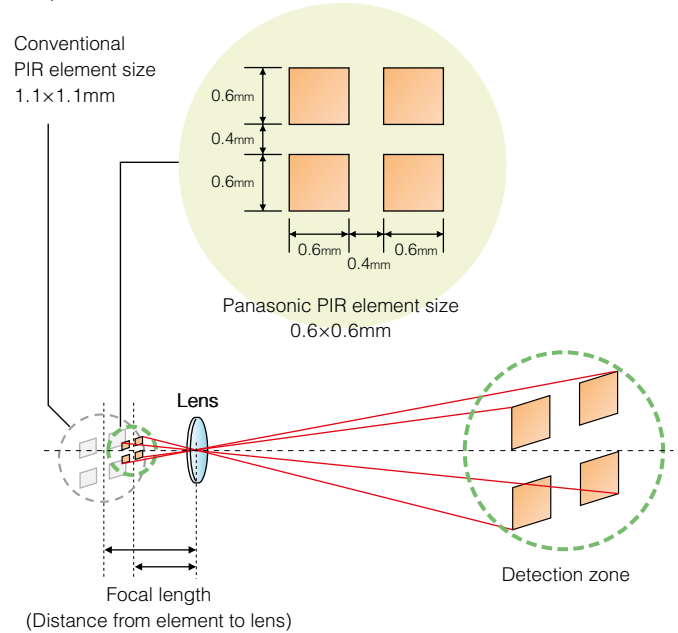

4 times better signal-to-noise ratio

Improved signal-to-noise ratio thanks to a special I/V circuit which is used for converting a current signal from the pyroelectric element to voltage. Panasonic PIR Motion sensors perform by the feedback capacitor and the operational amplifier, different from the conventional FET-type, thereby decreasing the probability of false alarms due to temperature fluctuation.

[PaPIRs] High S/N (= smaller steady noise)

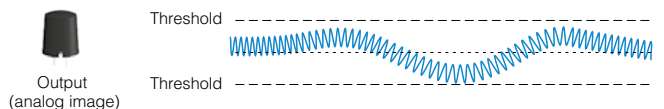

[Conventional Type] Low S/N (=bigger steady noise)

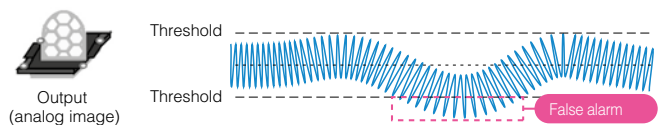

Low current consumption [EKMB(WL) series only]

Reduction of current consumption (1, 2 or 6μA) thanks to the special circuit design technology allows battery life to be extended for battery-driven products including wireless devices etc.

Extensive line-up to satisfy a variety of applications

Please choose based on your application and/or environmental requirement

((PaPIRs)) motion sensor

EKMB(WL) series

- > Low current consumption for battery-driven applications
- > A special differential input circuit design is introduced for the EKMB 6 μ A type for applications where a high noise resistance is required (up to GHz range)

NEW New type P.14

► Choose by lens

Lenses for the EKMB/ EKMC series



Standard detection type



Long distance detection type



Wall installation type

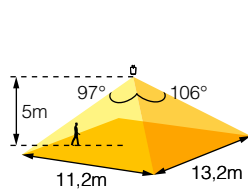

Standard detection type

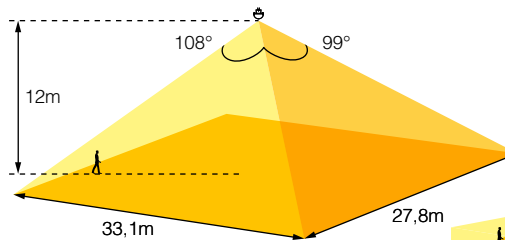

Long distance detection type

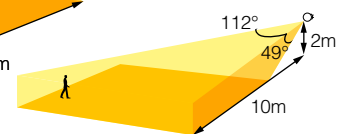

Wall installation type



Standard detection type



Long distance detection type



Wall installation type

► Choose by the current consumption in standby mode (1 μ A type: in sleep mode)

1 μ A

2 μ A

6 μ A

1 μ A

2 μ A

6 μ A

1 μ A

2 μ A

6 μ A

► Choose by output

Digital

► Choose by lens color

White

EKMB1101111 EKMB1201111 EKMB1301111K EKMB1103111 EKMB1203111 EKMB1303111K EKMB1104111 EKMB1204111 EKMB1304111K

Black

EKMB1101112 EKMB1201112 EKMB1301112K EKMB1103112 EKMB1203112 EKMB1303112K EKMB1104112 EKMB1204112 EKMB1304112K

Pearl white

EKMB1101113 EKMB1201113 EKMB1301113K EKMB1103113 EKMB1203113 EKMB1303113K EKMB1104113 EKMB1204113 EKMB1304113K

► Reference page

P. 5

and/or environmental requirements

EKMC(VZ) series

> Economy type suitable for a wide range of applications

NEW New type P.14

Lensless type available

The EKMB/EKMC series also offers a lensless type for those customers who design their own lens.

EKMB series

1 μ A type: EKMB1100100

2 μ A type: EKMB1200100

6 μ A type: EKMB1300100K



EKMC series

170 μ A type: EKMC1600100

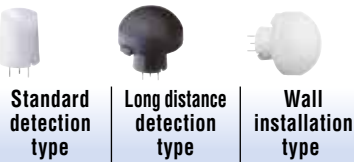

Standard detection type

Long distance detection type

Wall installation type

AMN(NaPiOn) series

> Line-up with special detection lenses for slight motion or narrow spot detection
> Digital and analog output types available

Lenses for the AMN series



Standard detection type



Slight motion detection type



Spot detection type



10m detection type

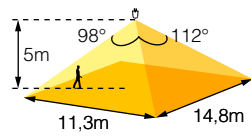

Standard detection type

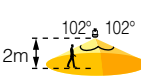

Slight motion detection type

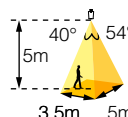

Spot detection type

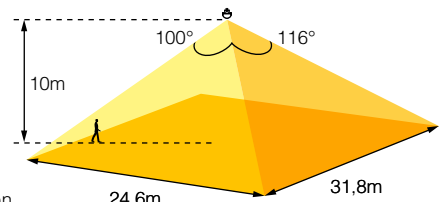

10m detection type



Standard detection type



Slight motion detection type



Spot detection type



10m detection type

170 μ A

170 μ A

Digital

Digital

Analog

Digital

Analog

Digital

Analog

Digital

Analog

EKMC1601111 EKMC1603111 EKMC1604111

AMN31112 AMN21112 AMN32112 AMN22112 AMN33112 AMN23112 AMN34112 AMN24112

EKMC1601112 EKMC1603112 EKMC1604112

AMN31111 AMN21111 AMN32111 AMN22111 AMN33111 AMN23111 AMN34111 AMN24111

EKMC1601113 EKMC1603113 EKMC1604113

P. 7

P. 9

EKMB(WL) series

Current consumption **1/2/6 μ A**

Digital output



Standard detection type



Long distance detection type



Wall installation type

- > Low-current consumption for battery-driven applications
- > A special differential input circuit design (EKMB 6 μ A type only) for applications where a high-noise resistance is required (up to GHz range)

Recommended applications

IoT, occupancy sensor module for smart home, battery-driven applications, wireless devices

Lensless type available

1 μ A type: EKMB1100100
2 μ A type: EKMB1200100

6 μ A type: EKMB1300100K

EKMB series

Specifications

Detection performance	Model no.	Current consumption	Lens color	Output type	Detection distance	Detection area		Detection zones
						Horizontal	Vertical	
Standard detection type 	EKMB1101111	1 μ A	White	Digital	5m	94° (106°)	82° (97°)	64
	EKMB1101112		Black					
	EKMB1101113		Pearl white					
	EKMB1201111	2 μ A	White					
	EKMB1201112		Black					
	EKMB1201113		Pearl white					
	EKMB1301111K	6 μ A	White					
	EKMB1301112K		Black					
	EKMB1301113K		Pearl white					
Long distance detection type 	EKMB1103111	1 μ A	White	Digital	12m	102° (108°)	92° (99°)	92
	EKMB1103112		Black					
	EKMB1103113		Pearl white					
	EKMB1203111	2 μ A	White					
	EKMB1203112		Black					
	EKMB1203113		Pearl white					
	EKMB1303111K	6 μ A	White					
	EKMB1303112K		Black					
	EKMB1303113K		Pearl white					
Wall installation type 	EKMB1104111	1 μ A	White	Digital	12m (1st step lens) 6m (2nd step lens) 3m (3rd step lens) Please refer to page 8 for details.	40° (55.6)	105° (112°)	68
	EKMB1104112		Black					
	EKMB1104113		Pearl white					
	EKMB1204111	2 μ A	White					
	EKMB1204112		Black					
	EKMB1204113		Pearl white					
	EKMB1304111K	6 μ A	White					
	EKMB1304112K		Black					
	EKMB1304113K		Pearl white					

EKMC series

AMN series

Ordering information

EKMB 1 1

- PaPIRs motion sensor
- Current consumption in standby mode
1: 1 μ A / 2: 2 μ A / 3: 6 μ A
- Detection (Lens)
00: Lensless / 01: 5m distance standard /
03: 12m long distance / 04: Wall installation type

- Others
K: 6 μ A / Blank: 1 μ A and 2 μ A
- Lens color
0: Lensless / 1: White /
2: Black / 3: Pearl white
- Lens
0: Lensless / 1: With lens

Characteristics

> Maximum rated values

Items	Value
Power supply voltage	-0.3 to 4.5V
Ambient temperature	-20 to +60°C (No frost, no condensation)
Storage temperature	-20 to +70°C

> Electrical Characteristics

Items	Symbol	1μA type	2μA type	6μA type	Conditions	
Operating voltage	Max	4.0V			-	
	Min	2.3V				
Current consumption (in standby mode) Note 1)	Ave	Iw	1μA	2μA	6μA	Ambient temperature: 25°C Iout=0 Vdd: 3V
Output current (during detection period) Note 2)	Max	Iout	100μA			Ambient temperature: 25°C Vout≥Vdd-0.5
Output voltage (during detection period)	Min	Vout	Vdd-0.5V			Ambient temperature: 25°C Open at no detection
Circuit stability time (when voltage is applied)	Ave	T _{wu}	25 seconds		-	Ambient temperature: 25°C Iout=0 Vdd: 3V
	Max		210 seconds		10 seconds, note 3)	

Note 1) The total current consumption is equal to the current consumption in standby mode (Iw) plus the output current during detection (Iout). For the 1μA type please note that the average current consumption is 1μA in sleep mode and 1.9μA in standby mode. Please also refer to the timing chart.

Note 2) Please select an output resistors (pull-down concept) in accordance with Vout so that the output current is lower than or equal to 100μA. If the output current is more than 100μA, this may cause false alarms.

Note 3) The sensor temperature is constant for the time specified.

Timing chart

> 2μA / 6μA type

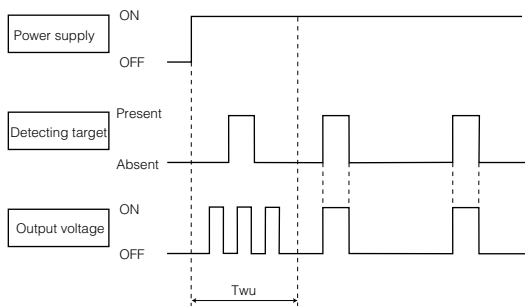

[Explanation of the timing]

T_{wu}: Circuit stability time: about 25 seconds (typ.) for 2μA type, max. 10 seconds for 6μA type.

While the circuitry is stabilizing after the power is turned on, the sensor output is not fixed in the ON or OFF state. This is true regardless of whether or not the sensor has detected anything.

> 1μA type

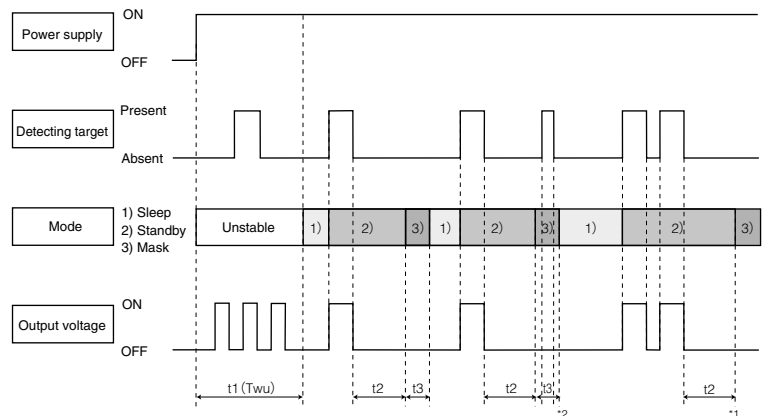

[Explanation of modes]

- 1) Sleep mode: When the output is OFF. The electrical current consumption is around 1μA.
- 2) Standby mode: After the sensor's output has reached ON status, the sensor switches to standby mode. The electrical current consumption gets close to 1.9μA. When the sensor's output returns to its OFF value after the "hold time" has expired, the sensor switches again to sleep mode.
- 3) Mask mode: Time during which the output is forced to OFF status after the end of the standby mode. (No detection is possible during this period.)

[Explanation of the timing]

- t₁ (T_{wu}): Circuit stability time: about 25 seconds (typ.)
While the circuitry is stabilizing after the power is turned on, the sensor output is not fixed in the ON or OFF state. This is true regardless of whether or not the sensor has detected anything.
- t₂: Standby hold time: about 2.6 seconds (typ.) after the last detection of a signal. (#1)
- t₃: Mask time: about 1.3 seconds (typ.) During this stage, even if the sensor detects something, the output will not switch to ON. (#2)

EKMC (VZ) series

Current consumption **170μA**

Digital output

EKMB series



Standard detection type



Long distance detection type

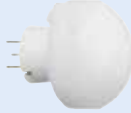

Wall installation type

> Economy type suitable for a wide range of applications

Recommended applications

Lighting control, lighting equipment, heaters, ventilators or air conditioners, IP cameras, intrusion alarms, digital signage, vending machines, multi-function printers, display panels for meeting rooms, PCs

Lensless type available
170μA type: EKMC1600100

EKMC series

Specifications

Detection performance	Model no.	Current consumption	Lens color	Output type	Detection distance	Detection area		Detection zones
						Horizontal	Vertical	
Standard detection type 	EKMC1601111	170μA	White	Digital	5m	94° (106°)	82° (97°)	64
	EKMC1601112		Black					
	EKMC1601113		Pearl white					
Long distance detection type 	EKMC1603111		White		12m	102° (108°)	92° (99°)	92
	EKMC1603112		Black					
	EKMC1603113		Pearl white					
Wall installation type 	EKMC1604111		White		12m (1st step lens) 6m (2nd step lens) 3m (3rd step lens)	40° (55.6°)	105° (112°)	68
	EKMC1604112		Black					
	EKMC1604113		Pearl white					

■ Ordering information

EKMC16 **1**

- PaPIRs motion sensor
- Detection (Lens)
00: Lensless / 01: 5m distance standard / 03: 12m long distance / 04: Wall installation type

- Lens color
0: Lensless / 1: White / 2: Black / 3: Pearl white
- Lens
0: Lensless / 1: With lens

AMN series

Characteristics

> Maximum rated values

Items	Value
Power supply voltage	-0.3 to 7V
Ambient temperature	-20 to +60°C (no frost, no condensation)
Storage temperature	-20 to +70°C

> Electrical characteristics

Items	Symbol	EKMC(VZ) type	Conditions
Operating voltage	Max	Vdd	6.0V
	Min		3.0V
Current consumption (in standby mode) Note 1)	Ave	Iw	170μA Ambient temperature: 25°C Iout=0 Vdd: 5V
Output current (during detection) Note 2)	Max	Iout	100μA Ambient temperature: 25°C Vout>Vdd-0.5
Output voltage (during detection period)	Min	Vout	Vdd · 0.5V Ambient temperature: 25°C Open at no detection
Circuit stability time (when voltage is applied)	Max	Twu	30 seconds Ambient temperature: 25°C Iout=0 Vdd: 5V

Note 1) Current consumption during detection period is the total value of current consumption in standby mode added to the output current.
Note 2) Please select an output resistors (pull-down concept) in accordance with Vout so that the output current is lower than or equal to 100μA. If the output current is more than 100μA, this may cause false alarms.

Timing chart

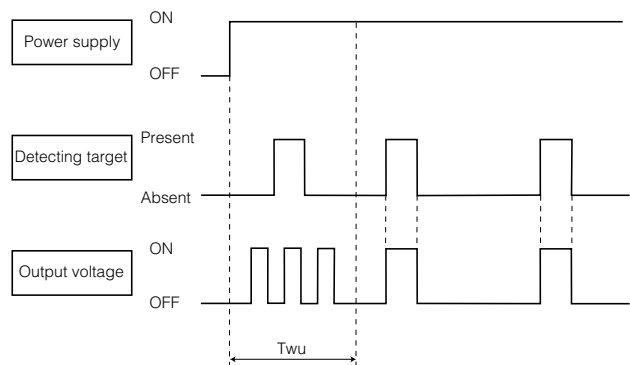

[Explanation of the timing]

Twu: Circuit stability time: max. 30 seconds
During this stage, the output's status is undefined (ON/OFF) and detection is therefore not guaranteed. This is true regardless of whether or not the sensor has detected anything.

Lenses for the EKMB/EKMC series

Standard detection type

CAD data



Dimension (mm)

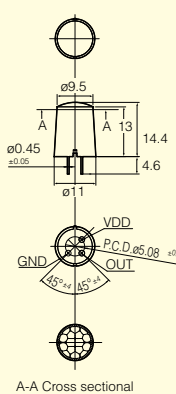

A-A Cross sectional

Detection zone

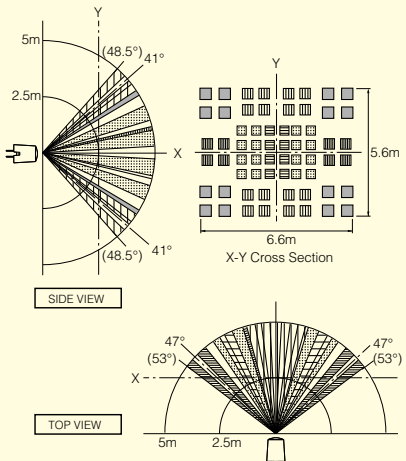

SIDE VIEW

TOP VIEW

Detection characteristics

Detection distance	Max. 5m*
Field of view	94°x82° (106°x97°)
Detection zone	64 beams
Detection condition ▲	<ul style="list-style-type: none"> The temperature difference between the target and the surroundings must be higher than 4°C. Movement speed: 1.0m/s Target concept: Human body with an approx. size of 700x250mm Target moving direction: Crossing the detection beam.

* Under specified detection conditions
▲ Please refer to "Caution for use" (page 13) and "Basic principles" (page 13, point 5) for more details

Please note that the horizontal and vertical field of view depends on the position of the metal tab on which the lens is mounted.

Long distance detection type

CAD data



Dimension (mm)

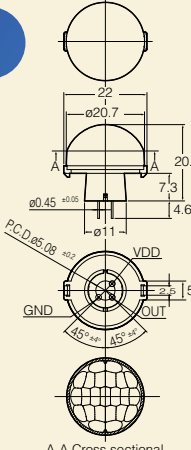

A-A Cross sectional

Detection zone

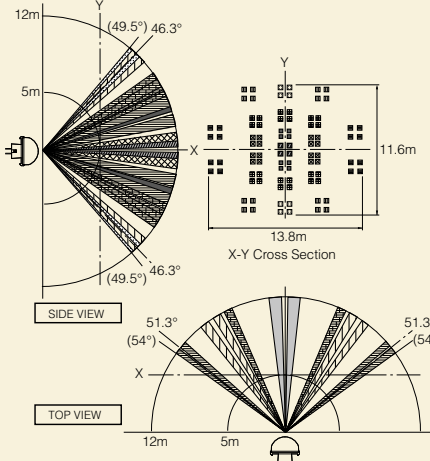

SIDE VIEW

TOP VIEW

Detection characteristics

Detection distance	Max. 12m*
Field of view	102°x92° (108°x99°)
Detection zone	92 beams
Detection condition ▲	<ul style="list-style-type: none"> The temperature difference between the target and the surroundings must be higher than 4°C. Movement speed: 1.0m/s Target concept: Human body with an approx. size of 700x250mm Target moving direction: Crossing the detection beam.

Wall installation type

CAD data



Dimension (mm)

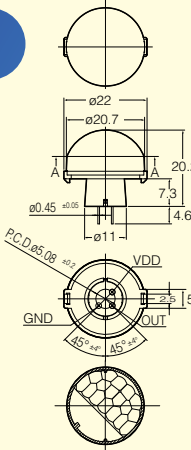

A-A Cross sectional

Detection zone

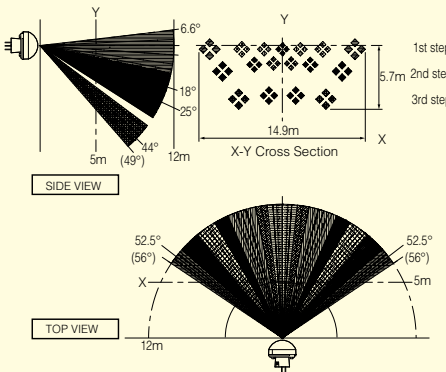

SIDE VIEW

TOP VIEW

Detection characteristics

Detection distance	1st step lens	Max. 12m*
	2nd step lens	Max. 6m*
	3rd step lens	Max. 3m*
Field of view	40°x105° (55.6°x112°)	
Detection zone	68 beams	
Detection condition	<ul style="list-style-type: none"> The temperature difference between the target and the surroundings must be higher than 4°C. Movement speed: 1.0m/s Target concept: Human body with an approx. size of 700x250mm Target moving direction: Crossing the detection beam. 	

Lensless type



PIR element

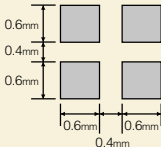

Dimension (mm)

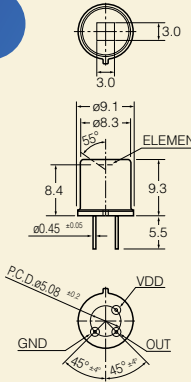

Detection sensitivity

Average: 5.6µW/cm ²
Maximum: 7.6µW/cm ²

※ Detection sensitivity is measured by following system

Test setup

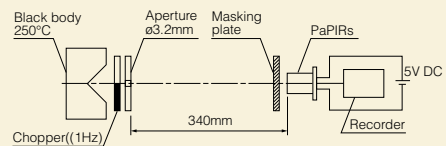

AMN (NaPiOn) series

Current consumption **170 μ A**

Digital/Analog output



Standard detection type



Slight motion detection type



Spot detection type



10m detection type

- > Line-up with special detection lenses for slight motion or very small objects
- > Digital and analog output types available

Recommended applications

Lighting control, lighting equipment, heaters, ventilators or air conditioners, IP cameras, intrusion alarms, digital signage, vending machines, multi-function printers, display panels for meeting rooms, PCs

EKMB series

EKMC series

AMN series

Specifications

Detection performance	Model no.	Current consumption	Lens color	Output type	Detection distance	Detection area		Detection zones	
						Horizontal	Vertical		
Standard detection type 	AMN31112	170 μ A	White	Digital	5m	100° (112°)	82° (98°)	64	
	AMN31111		Black	Analog					
	AMN21112		White						
	AMN21111		Black						
Slight motion detection type 	AMN32112		White	Digital	2m	92° (102°)	92° (102°)		104
	AMN32111		Black	Analog					
	AMN22112		White						
	AMN22111		Black						
Spot detection type 	AMN33112		White	Digital	5m	22° (40°)	38° (54°)	24	
	AMN33111		Black	Analog					
	AMN23112		White						
	AMN23111		Black						
10m detection type 	AMN34112		White	Digital	10m	110° (116°)	93° (100°)		80
	AMN34111		Black	Analog					
	AMN24112		White						
	AMN24111		Black						

Ordering information

AMN 1 1

- NaPiOn sensor
- Output type
2: Analog output / 3: Digital output (170 μ A)

- Lens color
1: Black / 2: White
- Detection (Lens)
1: Standard type / 2: Slight motion type / 3: Spot type / 4: 10m type

Characteristics

> Maximum rated values

Items	Value
Power supply voltage	-0.3 to 7V
Ambient temperature	-20 to +60°C (No frost, no condensation)
Storage temperature	-20 to +70°C

> Electrical characteristics (digital output)

Items	Symbol	Digital output	Conditions
Operating voltage	Max	6.0V	-
	Min	3.0V	
Current consumption (in standby mode) Note 1)	Ave	170μA	Ambient temperature: 25°C Iout=0 Vdd: 5V
Output current (during detection) Note 2)	Max	100μA	Ambient temperature: 25°C Vout≥Vdd-0.5
Output voltage (during detection)	Min	Vdd · 0.5V	Ambient temperature: 25°C Open at no detection
Circuit stability time (when voltage is applied)	Max	30 seconds	Ambient temperature: 25°C Iout=0 Vdd: 5V

Note 1) The total current consumption is equal to the current consumption in standby mode (Iw) plus the output current during detection (Iout).

Note 2) Please select an output resistor (pull-down concept) in accordance with Vout so that the output current is lower than or equal to 100μA. If the output current is more than 100μA, this may cause false alarms.

> Electrical characteristics (analog output)

Items	Symbol	Analog output	Conditions
Operating voltage	Max	5.5V	-
	Min	4.5V	
Current consumption (in standby mode) Note1)	Ave	Iw	170μA Ambient temperature: 25°C Iout=0 Vdd: 5V
Output current (during detection period) Note2)	Max	Iout	50μA Ambient temperature: 25°C Vdd: 5V
Output voltage range (during detection period)	Max	Vout	Vdd
	Min	Vout	0V
Output offset voltage (at non detection)	Max	Voff	2.7V
	Ave		2.5V
	Min		2.3V
Steady noise	Max	Vn	300mVpp Ambient temperature: 25°C Vdd: 5V
	Ave	Vn	155mVpp
Detection sensitivity	Min	Vh or Vl	0.45V Ambient temperature: 25°C Vdd: 5V
Circuit stability time (when voltage is applied)	Max	Twu	45 seconds Ambient temperature: 25°C Vdd: 5V

Note 1) The total current consumption is equal to the current consumption in standby mode (Iw) plus the output current during detection (Iout).

Note 2) To set the same detection sensitive as for the digital output type, set the output voltage to 2.5V ±0.45V

Timing chart

> Digital output

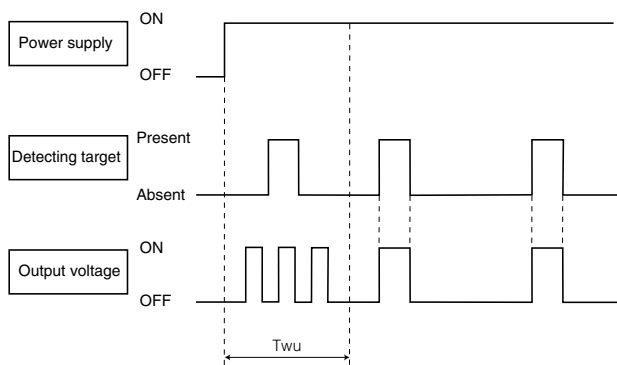

[Explanation of the timing]

Twu: Circuit stability time: max. 30 seconds
While the circuitry is stabilizing after the power is turned on, the sensor output is not fixed in the ON or OFF state. This is true regardless of whether or not the sensor has detected anything.

> Analog output

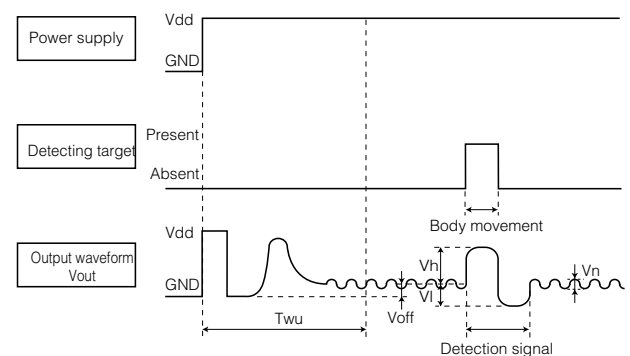

[Explanation of the timing]

Twu: Circuit stability time: max. 45 seconds
While the circuitry is stabilizing after the power is turned on, the sensor output is not fixed in the ON or OFF state. This is true regardless of whether or not the sensor has detected anything.

Lenses for the AMN series

EKMB series

EKMC series

AMN series

Dimension (mm)

Detection zone

Detection characteristics

Standard detection type

CAD data

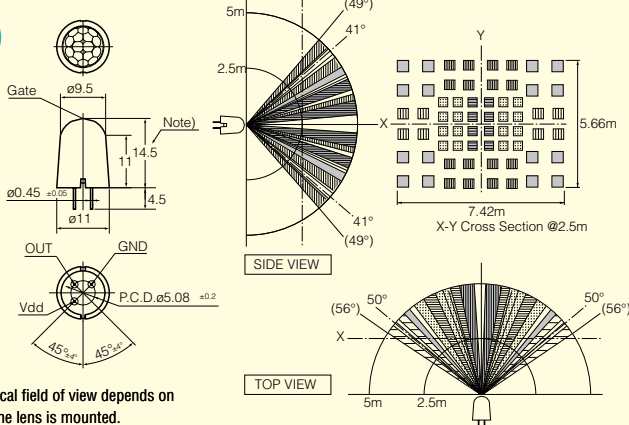

Please note that the horizontal and vertical field of view depends on the position of the metal tab on which the lens is mounted.

Detection distance	5m*
Field of view	100°x82° (112°x98°)
Detection zone	64 beams
Detection condition ▲	<ul style="list-style-type: none"> The temperature difference between the target and the surroundings must be higher than 4°C. Movement speed: Digital output 0.8 to 1.2m/s, Analog output 0.5 to 1.5m/s Target concept: Human body with an approx. size of 700x250mm Target moving direction: Crossing the detection beam.

* Under specified detection conditions
▲ Please refer to "Caution for use" (page 13) and "Basic principles" (page 13, point 5), for more details

Slight motion detection type

CAD data

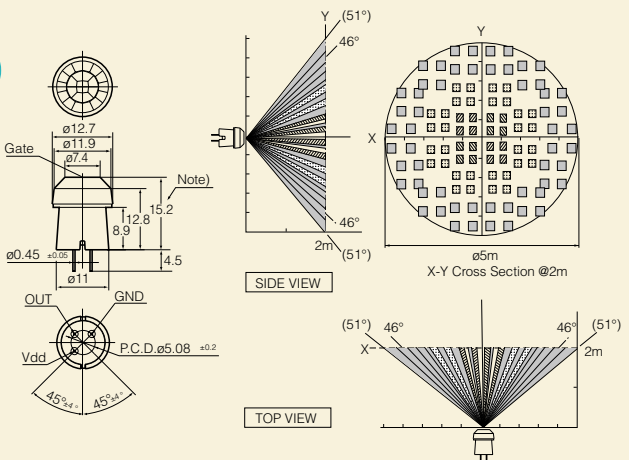

Detection distance	2m*
Field of view	92°x92° (102°x102°)
Detection zone	104 beams
Detection condition ▲	<ul style="list-style-type: none"> The temperature difference between the target and the surroundings must be higher than 4°C. Movement speed: Digital output 0.5m/s, Analog output 0.3 to 1.0m/s Target concept: Human body with an approx. size of 700x250mm Target moving direction: Crossing the detection beam.

Spot detection type

CAD data

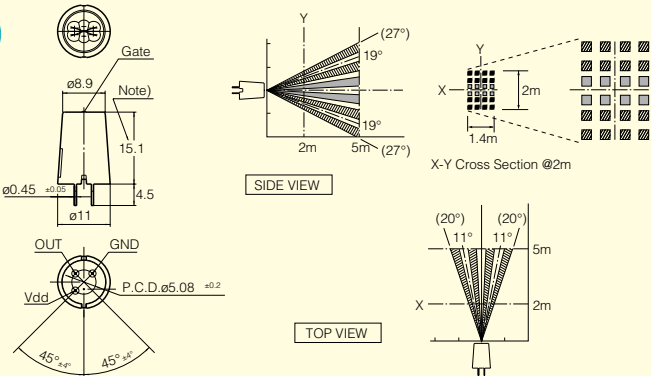

Detection distance	5m*
Field of view	22°x38° (40°x54°)
Detection zone	24 beams
Detection condition ▲	<ul style="list-style-type: none"> The temperature difference between the target and the surroundings must be higher than 4°C. Movement speed: Digital output 0.8 to 1.2m/s, Analog output 0.5 to 1.5m/s Target concept: Human body with an approx. size of 700x250mm Target moving direction: Crossing the detection beam.

10m detection type

CAD data

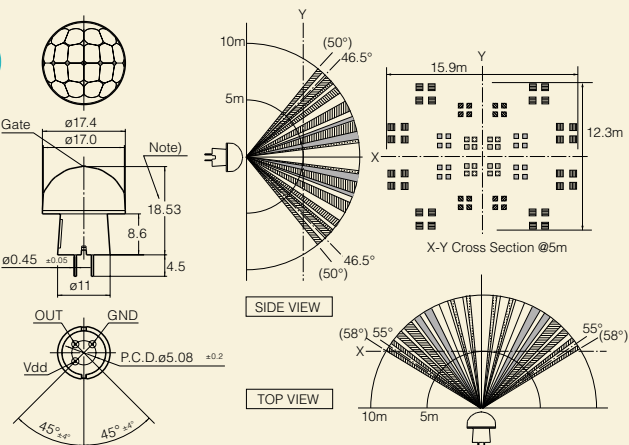

Detection distance	10m*
Field of view	110°x93° (116°x100°)
Detection zone	80 beams
Detection condition ▲	<ul style="list-style-type: none"> The temperature difference between the target and the surroundings must be higher than 4°C. Movement speed: Digital output 0.8 to 1.2m/s, Analog output 0.5 to 1.5m/s Target concept: Human body with an approx. size of 700x250mm Target moving direction: Crossing the detection beam.

➤ Block diagram output circuit

1) Digital output with integrated amplifier and comparator

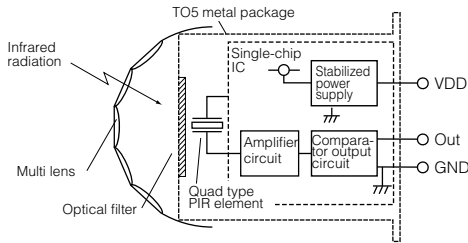

2) Analog output with integrated amplifier

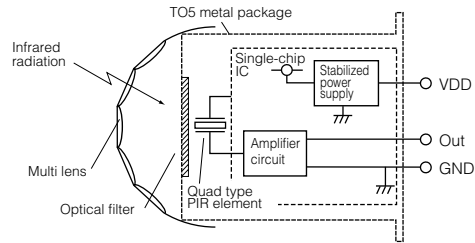

➤ Wiring diagram

1) Digital output

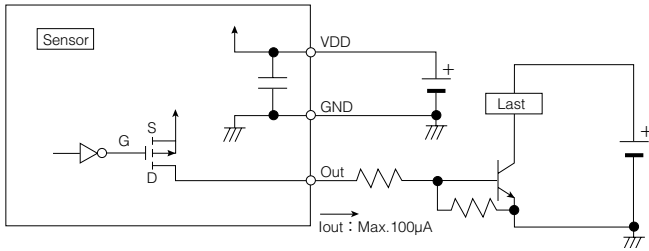

2) Analog output

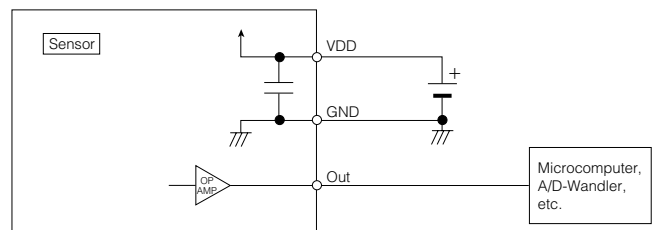

Vdd: Input power source (DC), GND: GND, Out: Output (Comparator)

Note) The output signal for the digital output type is from inside FET drain, therefore pull-down resistors are necessary. Please select an output resistor (pull-down concept) in accordance with V_{out} so that the output current is lower than or equal to $100\mu A$. Use $50K\Omega$ or more as a guideline. If the output current is more than $100\mu A$, this may cause false alarms.

➤ Timer circuit example

1) Digital output

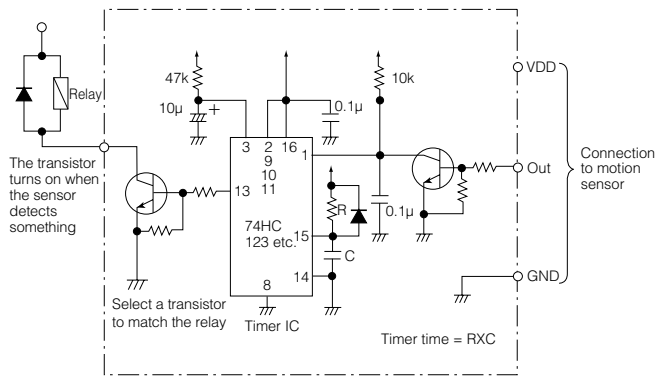

2) Analog output

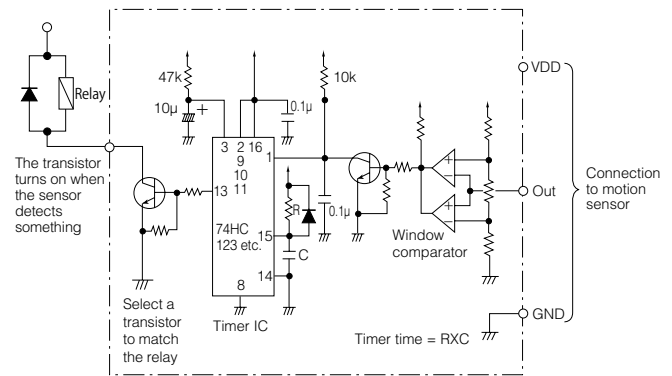

Note) This is the reference circuit which drives the PIR motion sensor. Install a noise filter for applications requiring enhanced detection reliability and noise withstanding capability. Differences in the specifications of electronic components to which the units are connected sometimes affect their correct operation; please check the units' performance and reliability for each application. Panasonic Corporation, Ltd. accepts no responsibility for damages resulting from the use of this circuit.

➤ Mounting direction

1) As shown in the diagram on the right, please install the sensor so that the expected trespassing direction corresponds to the X or Y direction. In some cases, moving towards or away from the sensor (parallel movement to the Z direction) may not be detected as expected sensitivity or distance.

2) * 1 Please note that the horizontal and vertical field of view depends on the position of the metal tab on which the lens is mounted.

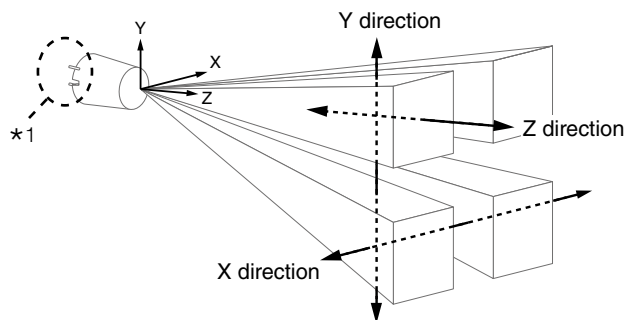

› Basic principles

PaPIRs are pyroelectric infrared sensors that detect variations in infrared rays. However, detection may not be successful in the following cases: lack of movement or no temperature change in the heat source. They could also detect the presence of heat sources other than a human body. Efficiency and reliability of the system may vary depending on the actual operating conditions:

- 1) Detecting heat sources other than the human body, such as:
 - a) small animals entering the detection area
 - b) When a heat source, for example sun light, incandescent lamp, car headlights etc., or strong light beam hit the sensor regardless whether the detection area is inside or outside.
 - c) Sudden temperature change inside or around the detection area caused by hot or cold wind from HVAC, or vapor from a humidifier, etc.
- 2) Difficulty in sensing the heat source
 - a) Glass, acrylic or similar materials standing between the target and the sensor may not allow a correct transmission of infrared rays.
 - b) Non-movement or quick movements of the heat source inside the detection area. (Please refer to the table on page 8 or 11 for details about movement speed.)
- 3) Expansion of the detection area
In case of a considerable difference in the ambient temperature and the human body temperature, the detection area may be larger than the configured detection area.
- 4) Malfunction / Detection error
On rare occasions, an erroneous detection signal may be output due to the nature of pyroelectric element. When the application cannot tolerate erroneous detection signals, take countermeasures by introducing a pulse-count circuit, etc.
- 5) Detection distance
Panasonic's PIR Motion sensors state the detection distance in the specifications because they are usually provided with the lens (please refer to item 6 for lensless types). The PIR Motion sensor could detect variations in infrared rays however such variations are decided by following three factors.
 - The temperature difference between the target and the surroundings:
The larger the temperature difference, the easier it is to detect targets.
 - Movement speed: If the target is moving at a slower or faster speed than specified in the tables, the detection ability may be lower.
 - Target size: The human body is the standard. If the target is smaller or larger than specified in the table, the detection ability may be lower.

The detection distance explained in our data sheet is defined by the three factors mentioned above. Panasonic's standard for the temperature difference between the target and the surrounding is defined as 4°C. The larger the temperature difference, the longer the detection distance. If the temperature difference is 8°C, which is twice as much as the standard, the detection distance will be approx. 1.4 times longer than the distance at 4°C. For example, if targets at a distance of 5m can be detected at 4°C, then the sensor can detect targets at a distance of 7m at 8°C. (This is based on the theory that the detection sensitivity will vary inversely with the square of the distance.)
- 6) Lensless type
The lensless type cannot detect any targets because it is not possible to focus infrared variations into the sensor chip. It is not possible to determine the detection distance and the field of view without a lens. Please provide your own lens based on your lens design concept.
- 7) Lens material and the plate setting in front of the lens
Typically, the only material that can be passed by infrared rays is Polyethylene. (The lens material of Panasonic's PIR Motion sensors is "High density polyethylene, HDPE".) When you need to set a plate in front of the lens, please choose one made from the Polyethylene. Please note the thickness or color of the plate will affect the detection ability, e.g. it may make the detection distance shorter. Therefore, please confirm by testing the sensor with the plate under realistic conditions.

› Cautions

- 1) Refer to the newest specification regarding optimal operating environment conditions.
- 2) Do not solder with a soldering iron above 350°C (662°F) or for more than 3 seconds. This sensor should be hand-soldered.
- 3) To maintain stability of the product, always mount it on a printed circuit board.
- 4) Do not use liquids to wash the sensor. If washing fluid gets into the lens, it can reduce the performance.
- 5) Do not use a sensor after it has fallen on the ground.
- 6) The sensor may be damaged by ±200 volts of static electricity. Avoid direct hand contact with the pins and be very careful when operating the product.
- 7) When wiring the product, always use shielded cables and minimize the wiring length to prevent noise disturbances.
- 8) The inner circuit board can be destroyed by a voltage surge. The use of surge absorption elements is highly recommended. Surge resistance: below the power supply voltage value indicated in the section on maximum rated values.
- 9) Please use a stabilized power supply. Noise from the power supply can cause operating errors. Noise resistance: max. ±20V (square waves with a width of 50ns or 1µs) To reduce the effect of noise from the power supply, install a capacitor on the sensor's power supply pin.
- 10) Operation errors can be caused by noise from static electricity, lightnings, cell phones, amateur radio, broadcasting offices, etc
- 11) The detection performance can be reduced by dirt on the lens, please be careful.
- 12) The lens is made of soft materials (Polyethylene). Please avoid adding weight or impacts that may change its shape, causing operation errors or reduced performance.
- 13) The specified temperature and humidity levels are suggested to prolong usage. However, they do not guarantee durability or environmental resistance. Generally, high temperatures or high humidity levels will accelerate the deterioration of electrical components. Please consider both the planned usage and environment to determine the expected reliability and length of life of the product.
- 14) Do not attempt to clean this product with detergents or solvents such as benzene or alcohol, as these can cause shape or color alterations.
- 15) Avoid storage in high, low temperature or liquid environments. Also, avoid storage in environments containing corrosive gas, dust, salty air etc. Adverse conditions may cause performance deterioration and the sensor's main part or the metallic connectors could be damaged.
- 16) Storage conditions
Temperature: +5 to +40°C, humidity: 30 to 75%
Please use within 1 year after delivery.

› Safety precautions

Obey the following precautions to prevent injury or accidents.

- 1) Do not use these sensors under any circumstance in which the range of their ratings, environment conditions or other specifications are exceeded. Using the sensors in any way which causes their specifications to be exceeded may generate abnormally high levels of heat, emit smoke, etc., resulting in damage to the circuitry and possibly causing an accident.
- 2) Our company is committed to making products of the highest quality and reliability. Nevertheless, all electrical components are subject to natural deterioration, and durability of a product will depend on the operating environment and conditions of use. Continued use after such deterioration could lead to overheating, smoke or fire. Always use the product in conjunction with proper fire-prevention, safety and maintenance measures to avoid accidents, reduction in product life expectancy or break-down.
- 3) Before connecting, check the pin layout by referring to the connector wiring diagram, specifications diagram, etc., to verify that the connector is connected properly. Mistakes made in connection may cause unforeseen problems in operation, generate abnormally high levels of heat, emit smoke, etc., resulting in damage to the circuitry.
- 4) Do not use any motion sensor which has been disassembled or remodeled.
- 5) Failure modes of sensors include short-circuiting, open-circuiting and temperature rises. If this sensor is to be used in equipment where safety is a prime consideration, examine the possible effects of these failures on the equipment concerned, and ensure safety by providing protection circuits or protection devices.
Example : Safety equipment and devices, traffic signals, burglar and disaster prevention devices, controlling and safety device for trains and motor vehicles

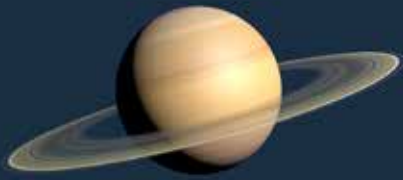

Standard- and slight-motion detection type

2 functions in 1 lens

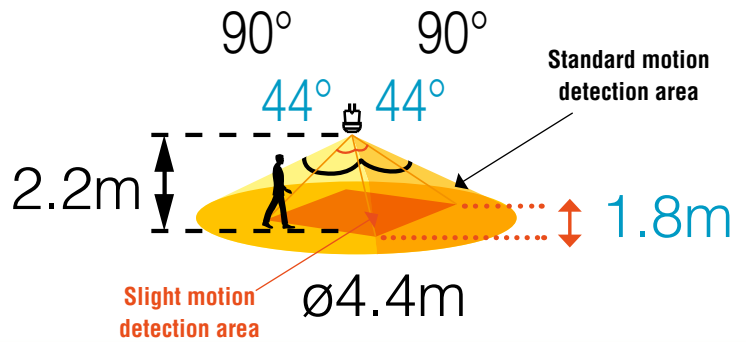

Standard and slight-motion detection type

Choose by the current consumption in standby mode (1µA type: in sleep mode)	1µA	2µA	6µA	170µA		
	Digital			Digital	Analog	
Choose by lens color	White	EKMB1193111	EKMB1293111	EKMB1393111K	EKMC1693111	By request
	Black	EKMB1193112	EKMB1293112	EKMB1393112K	EKMC1693112	By request
	Pearl white	EKMB1193113	EKMB1293113	EKMB1393113K	EKMC1693113	By request

Saturn lens

Dimension (mm)	Detection zone	Detection characteristics
<p>Standard and slight-motion detection type</p> <p>CAD data by request</p>	<p>Detection distance</p> <p>Max. 2.2m*</p> <p>Field of view</p> <p>Slight motion: 44° x 44° Standard motion: 90° x 90°</p> <p>Detection zone</p> <p>Slight motion: 36 Standard motion: 48</p> <p>Detection condition ▲</p> <p>Slight motion</p> <ul style="list-style-type: none"> The temperature difference between the target and the surroundings must be higher than 4°C. Movement speed: 0.5ms Target concept: Human head with an approx. size of 200x200mm Target moving direction: Crossing the detection beam, 1 zone <p>Standard motion</p> <ul style="list-style-type: none"> The temperature difference between the target and the surroundings must be higher than 4°C. Movement speed: 1.0ms Target concept: Human body with an approx. size of 400x200mm Target moving direction: Crossing the detection beam, 2 zones 	

* Under specified detection conditions
 ▲ Please refer to "Caution for use" (page 13) and "Basic principles" (page 13, point 5), for more details



North America

Europe

Asia Pacific

China

Japan

Panasonic Electric Works

Please contact our Global Sales Companies in:

Europe

▶ Headquarters	Panasonic Electric Works Europe AG	Robert-Koch-Straße 100, 85521 Ottobrunn, Tel. +49 89 45354-1000, Fax +49 89 45354-2111, www.panasonic-electric-works.com
▶ Austria	Panasonic Electric Works Austria GmbH	Josef Madersperger Str. 2, 2362 Biedermansdorf, Tel. +43 (0) 2236-26846, Fax +43 (0) 2236-46133 www.panasonic-electric-works.at
	Panasonic Industrial Devices Materials Europe GmbH	Ennschafenstrasse 30, 4470 Enns, Tel. +43 (0) 7223 883, Fax +43 (0) 7223 88333, www.panasonic-electronic-materials.com
▶ Benelux	Panasonic Electric Works Sales Western Europe B.V.	De Rijn 4, (Postbus 211), 5684 PJ Best, (5680 AE Best), Netherlands, Tel. +31 (0) 499 372727, Fax +31 (0) 499 372185, www.panasonic-electric-works.nl
▶ Czech Republic	Panasonic Electric Works Europe AG, organizační složka	Administrative centre PLATINIUM, Veverí 3163/111, 616 00 Brno, Tel. +420 541 217 001, Fax +420 541 217 101, www.panasonic-electric-works.cz
▶ France	Panasonic Electric Works Sales Western Europe B.V.	Succursale française, 10, rue des petits ruisseaux, 91370 Verrières Le Buisson, Tél. +33 (0) 1 6013 5757, Fax +33 (0) 1 6013 5758, www.panasonic-electric-works.fr
▶ Germany	Panasonic Electric Works Europe AG	Robert-Koch-Straße 100, 85521 Ottobrunn, Tel. +49 (0) Tel. +49 (0) 45354-1000, Fax +49 (0) 45354-2111, www.panasonic-electric-works.de
▶ Hungary	Panasonic Electric Works Europe AG	Magyarországi Közvetlen Kereskedelmi Képviselet, 1117 Budapest, Neumann János u. 1., Tel. +43 2236 26846-25, Mobile: +36 20 264 9896, Fax +43 2236 46133, www.panasonic-electric-works.hu
▶ Ireland	Panasonic Electric Works UK Ltd.	Irish Branch Office, Dublin, Tel. +353 (0) 14600969, Fax +353 (0) 14601131, www.panasonic-electric-works.co.uk
▶ Italy	Panasonic Electric Works Italia srl	Via del Commercio 3-5 (Z.I. Ferlina), 37012 Bussolengo (VR), Tel. +39 0456752711, Fax +39 0456700444, www.panasonic-electric-works.it
▶ Nordic Countries	Panasonic Electric Works Europe AG Panasonic Eco Solutions Nordic AB	Filial Nordic, Knarrarnäsgatan 15, 164 40 Kista, Sweden, Tel. +46 859476680, Fax +46 859476690, www.panasonic-electric-works.se
▶ Poland	Panasonic Electric Works Polska sp. z o.o	Jungmansgatan 12, 21119 Malmö, Tel. +46 40 697 7000, Fax +46 40 697 7099, www.panasonic-fire-security.com
▶ Spain	Panasonic Electric Works España S.A.	ul. Wołoska 9A, 02-583 Warszawa, Tel. +48 22 338-11-33, Fax +48 22 338-12-00, www.panasonic-electric-works.pl
▶ Switzerland	Panasonic Electric Works Schweiz AG	Barajas Park, San Severo 20, 28042 Madrid, Tel. +34 913293875, Fax +34 913292976, www.panasonic-electric-works.es
▶ United Kingdom	Panasonic Electric Works UK Ltd.	Grundstrasse 8, 6343 Rotkreuz, Tel. +41 (0) 41 7997050, Fax +41 (0) 41 7997055, www.panasonic-electric-works.ch
		Sunrise Parkway, Linford Wood, Milton Keynes, MK14 6 LF, Tel. +44 (0) 1908 231555, Fax +44 (0) 1908 231599, www.panasonic-electric-works.co.uk

North & South America

▶ USA	Panasonic Industrial Devices Sales Company of America	629 Central Avenue, New Providence, N.J. 07974, Tel. 1-908-464-3550, Fax 1-908-464-8513, www.pewa.panasonic.com
--------------	--	---

Asia Pacific/China/ Japan

▶ China	Panasonic Electric Works Sales (China) Co. Ltd.	Level 2, Tower W3, The Towers Oriental Plaza, No. 2, East Chang An Ave., Dong Cheng District, Beijing 100738, Tel. +86-10-5925-5988, Fax +86-10-5925-5973
▶ Hong Kong	Panasonic Industrial Devices Automation Controls Sales (Hong Kong) Co., Ltd.	RM1205-9, 12/F, Tower 2, The Gateway, 25 Canton Road, Tsimshatsui, Kowloon, Hong Kong, Tel. +852-2956-3118, Fax +852-2956-0398
▶ Japan	Panasonic Corporation	1048 Kadoma, Kadoma-shi, Osaka 571-8686, Japan, Tel. +81-6-6908-1050, Fax +81-6-6908-5781, www.panasonic.net
▶ Singapore	Panasonic Industrial Devices Automation Controls Sales Asia Pacific	300 Beach Road, #16-01 The Concourse, Singapore 199555, Tel. +65-6390-3811, Fax +65-6390-3810