

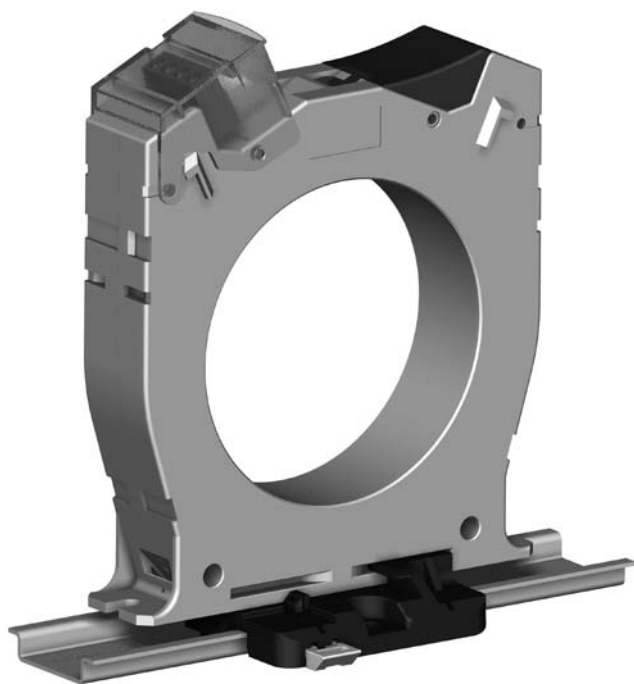

$\Delta IC / \Delta IP$

Differential toroid



USER INSTRUCTIONS

EN $\Delta IC / \Delta IP$ Differential toroid

Contents

Preliminary operations	2
Warning	2
In detail	3
Mounting	4
Mechanical characteristics	8
Connection	10
References/electrical and environmental specifications	14

Preliminary operations

Check the following points upon delivery of the package containing the toroid:

- the packaging and product are in good condition
- the product reference corresponds to your order
- the contents of the package:
 - 1 product
 - 1 cover (ΔIP only)
 - 1 detachable terminal block (mounted)
 - 1 mounting accessory (ΔIP only)
 - 1 Quick Start

Warning



Risk of electrocution, burns or explosion.

- the devices must only be installed and serviced by qualified personnel
- Switch off all power supplies before working on or in the equipment.
- Always use an appropriate voltage detection device to confirm the absence of voltage.
- Replace all devices, doors and covers before switching on the power to this equipment.
- Ensure that no metal objects are allowed to fall in the cabinet (risk of electrical arcing).

Failure to observe these safety instructions will expose the technician and those around him to the risk of serious injury or death.



Risk of damaging device

- If the toroid is dropped, there is a risk that the magnetic elements will be altered and the toroid should ideally be replaced.
- Ensure that the toroid is connected to the measuring or protection equipment indicated on the toroid.

In detail

 $\Delta IC / RESYS - DIRIS A80$

EN

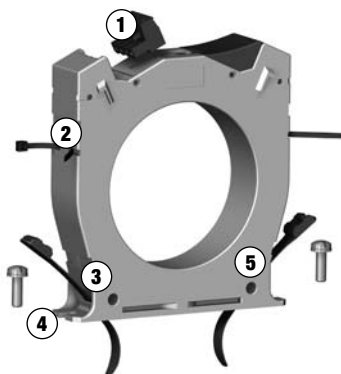

- ① Detachable screw terminal block
- ② Opening for fixing cables using clamps
- ③ Opening for fixing the toroid using clamps
- ④ Screwed connections
- ⑤ Opening for bracket mounting screw

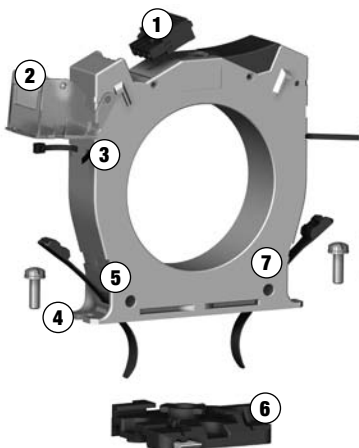
 $\Delta IP / ISOM$ 

- ① Detachable push-in terminal block
- ② Sealable protective cover
- ③ Opening for fixing cables using clamps
- ④ Screwed connections
- ⑤ Opening for fixing the toroid using clamps
- ⑥ Rotary mounting for DIN rail
- ⑦ Opening for bracket mounting screw

Mounting

EN

$\Delta IC / \Delta IP$

Direct screw mounting

■ Toroid mounted with 2 M4/1.5 Nm max. (\emptyset 15, 30 and 50 mm) screws, 2xM5/3.5 Nm max. (\emptyset 80 mm) screws, 2xM6/6 Nm max. (\emptyset 120 mm) screws or 4xM6/6 Nm max. (\emptyset 200 and 300 mm) screws + DIN433 washers. Use of self-cutting pan head screws, metric thread, Z-shaped cruciform (Pozidriv).

Screws not provided.

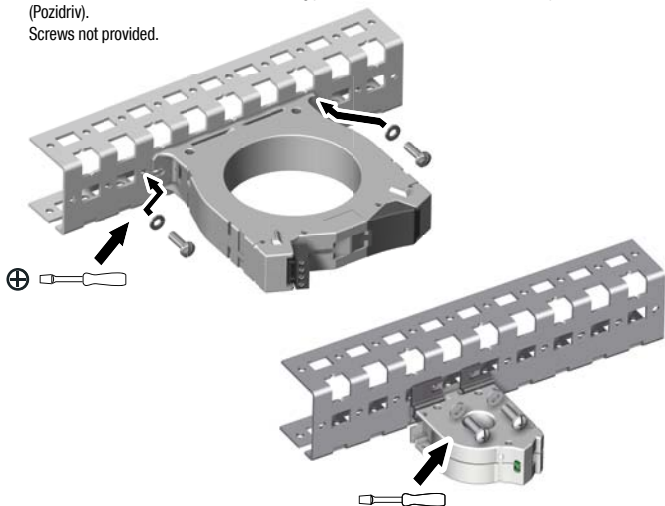

Clamp mounting (for toroid \emptyset 15 to 120 mm)

■ Toroid mounted with clamps of width 9 mm min. - 12 mm max., min. clamping radius less than 25 mm.

Clamps not supplied.

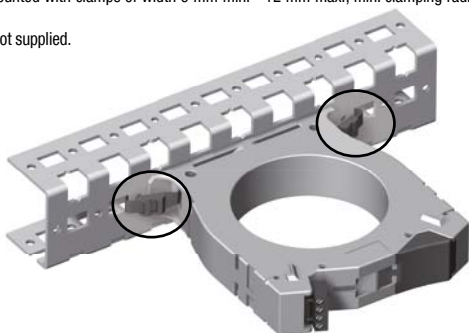

Mounting a \emptyset 300 mm toroid

Fit an additional cross member to support the toroid.

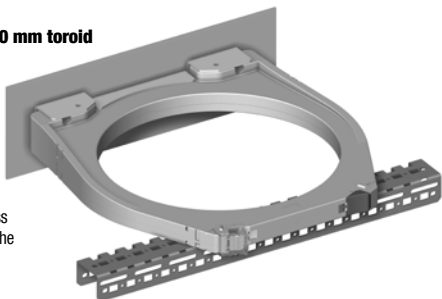

Metal bracket mounting (order as an accessory)**STEP 1**

- Mounting the bracket on a plate using M5 or M6 screws.
M5 max. torque: 3.5 Nm - M6 max. torque: 6 Nm.
Screws not provided.

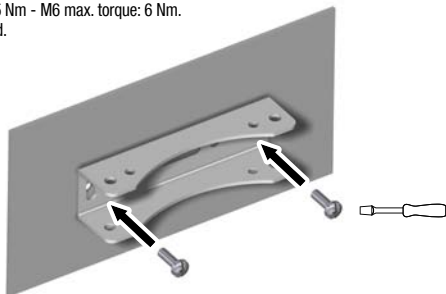
**STEP 2**

- Mounting the toroid on the bracket with the screws supplied

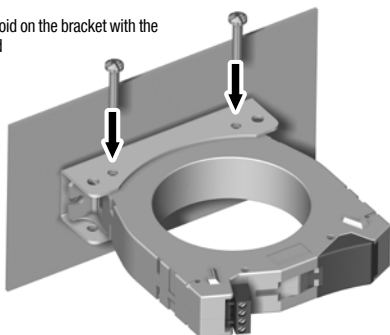
 **ΔIP (30, 50, 80 & 120 mm)****Mounting via DIN rail (order as an accessory)**

- Option to mount on 2 sides for \varnothing 30 mm toroid.

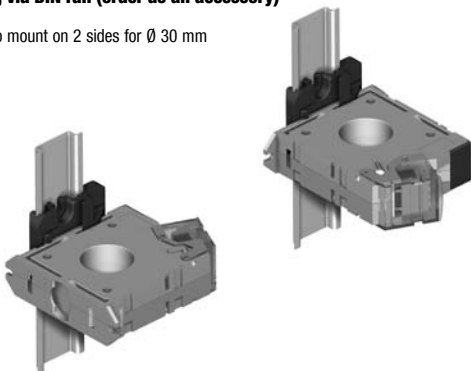

EN **Mounting via plate support or DIN rail (order as an accessory)**

STEP 1

Plate-mounted

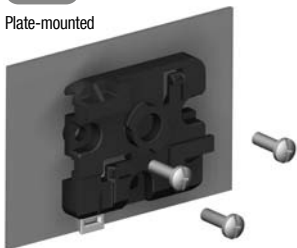

Secured with 3 M5 screws,
tightening torque 3.5Nm

DIN rail-mounted

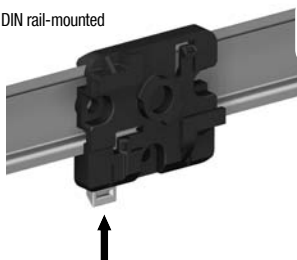

Screws not provided

STEP 2

■ Offer up the toroid at an angle of 45° and press.

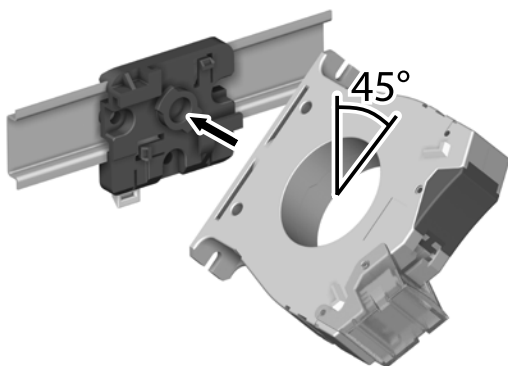

STEP 3

■ Turn the toroid 45° in the desired direction.

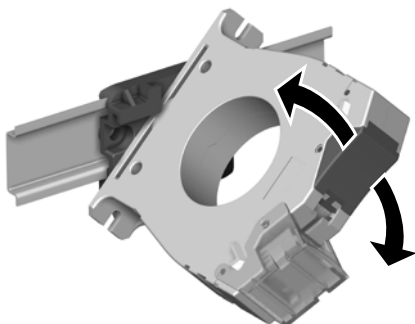

STEP 4

Or

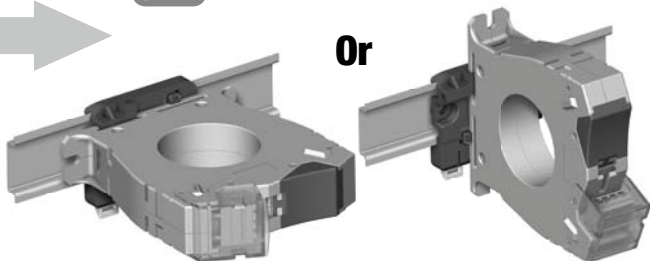

Dismantling the toroid

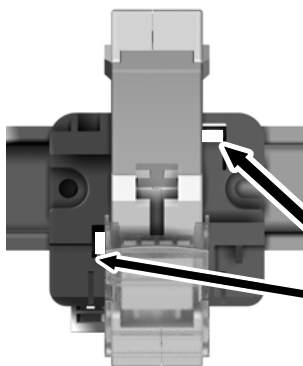

■ Press the 2 clips simultaneously and turn.

Staggered assembly of Ø 15 mm toroid

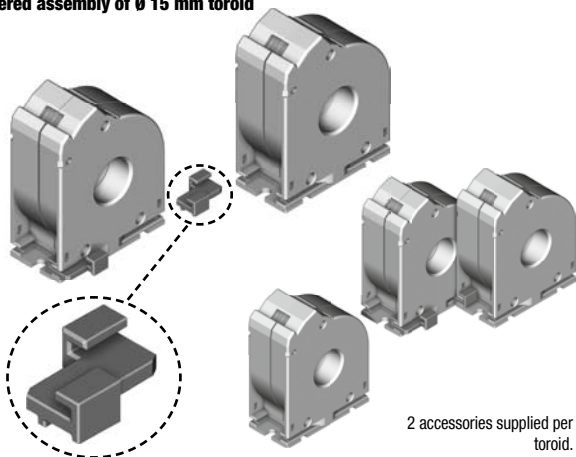



2 accessories supplied per toroid.

Mechanical characteristics

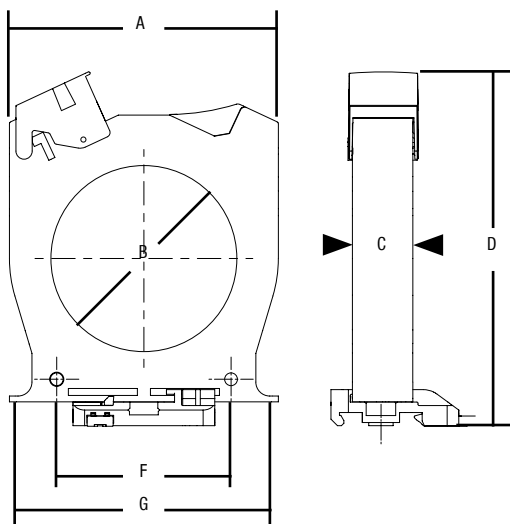
EN



	Ø 15 mm	Ø 30 mm	Ø 50 mm
--	---------	---------	---------

			
ΔIC	4950 6015	4950 6030	4950 6050
ΔIP	4750 6015	4750 6030	4750 6050
$\Delta IP/8$	4750 8015	4750 8030	
A (mm)	53	92	102,5
B (mm)	17,3	30	50
C (mm)	26	26	26
D (mm)	81	103,5	125
E (mm)	71	112	133
F (mm)	27,8	50	50
G (mm)	50	85	90
H (mm)	-	25/50	25/50
Weight (kg) ΔIC	0,10	0,13	0,18
Weight (kg) ΔIP	0,10	0,15	0,27
Weight (kg) $\Delta IP/8$	0,12	0,18	

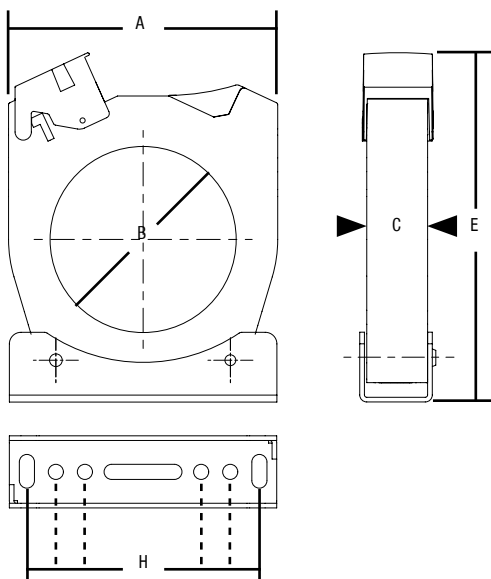

Ø 80 mm

Ø 120 mm

Ø 200 mm

Ø 300 mm

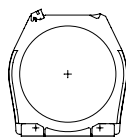

4950 6080
4750 6080

4950 6120
4750 6120

4950 6200
4750 6200

4950 6300
4750 6300

116

163

253

370

80

120

200

300

26

26

51

50

142,5

182,5

274

390

152

192

282

150

75

100

150

200

105

150

175 x 41,2

250 x 41,5

50/75/100

50/75/100

50/100/175

200/225/250 x 25

0,22
0,38

0,38
0,72

0,88
1,74

1,72
3,60

Connection

EN Conductor openings

- Selection of toroids based on the power circuit and min. $I\Delta n$ value recommended for high homopolar current (as per 6xIn tests in accordance with CEI 60947-2 appendix M)

Rated operational current I_n	Max. cross-section per conductor	Toroid	$I\Delta n$
36 A	6 mm ²	$\Delta IC/\Delta IP \ \phi 15$	30 mA
65 A	25 mm ²	$\Delta IC/\Delta IP \ \phi 30$	30 mA
85 A	50 mm ²	$\Delta IC/\Delta IP \ \phi 50$	30 mA
160 A	95 mm ²	$\Delta IC/\Delta IP \ \phi 80$	100 mA
250 A	240 mm ²	$\Delta IC/\Delta IP \ \phi 120$	300 mA ($\Delta IP:100$)
400 A	2 x 185 mm ²	$\Delta IC/\Delta IP \ \phi 200$	300 mA
630 A	2 x 240 mm ²	$\Delta IC/\Delta IP \ \phi 300$	300 mA

Note: With Cu 3 P+N cables

Recommendation for commissioning toroids in relation to the power cables

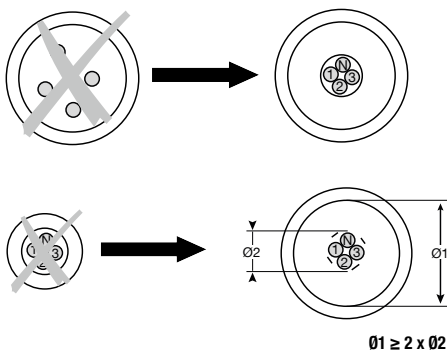
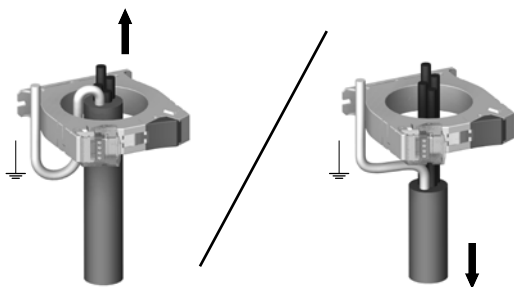

Using the centring device for Ø30 to 120 mm toroids (order as an accessory)

Patent application filed

STEP 1

- Open and secure the wires or cables

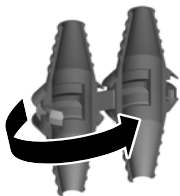

STEP 2

- Adapt the centring device to the cable cross section

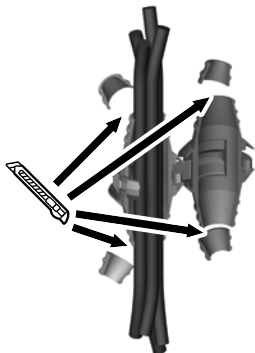

STEP 3

- Close the centring device

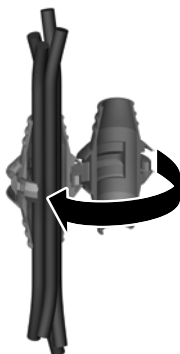

STEP 4

- Fit and tighten the clamps

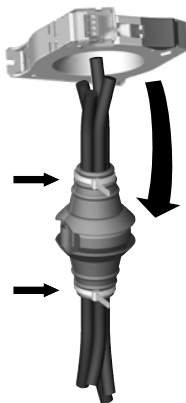

STEP 5

- Insert the centring device in the toroid



Connecting the toroid

STEP 1

- Open the cover (accessory for ΔIC)
- Remove the detachable terminal block

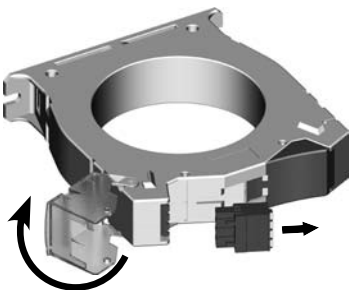

STEP 2

Cable terminals K (x1) and L (x1)

ΔIC : screw terminal block

- 3.5 mm straight screwdriver, max. torque 0.6 Nm, cross section 0.2 to 2.5 mm² (recommendation 0.8 mm²)

ΔIP : push-in terminal block

- wire with end ferrule, cross section 0.2 to 2.5 mm²

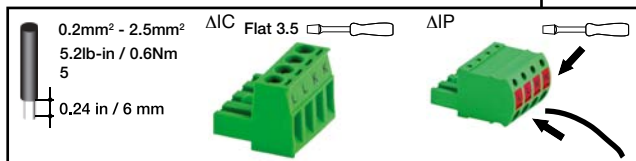
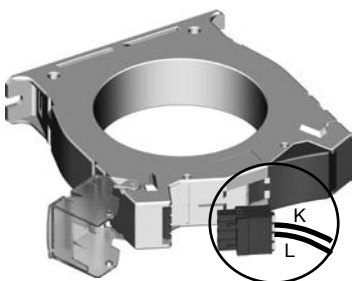

STEP 3

- Reconnect the detachable terminal block
- Close the cover (accessory for ΔIC)

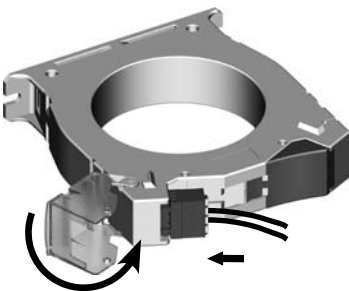

STEP 4

- Seal the cover (optional)



Testing the toroid





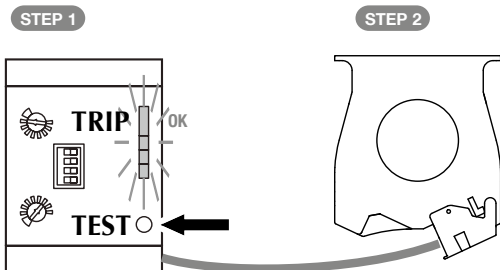

STEP 1 Connect the toroid to the relay (example below with RESYS M40 relay: see relay manual for connection details)

STEP 2 The final tests must be confirmed by "Test OK" (see table below)

Periodic testing must be carried out on the device to ensure compliance with regulations and to check the installation's connection and normative earth resistance values.

	Bar graph flashing	
	"Trip" LED and "Alarm" relay activated	
> Permanent test		
Test OK	NO	NO
Toroid input short circuit	NO	NO
Relay/Toroid connection break	YES	NO
> Press "test" button (> 1s)		
Test OK	YES	YES
Toroid input short circuit	NO	NO
Relay/Toroid connection break	YES	NO



	Ø15	Ø15/8	
$\Delta I C$ reference	4950 6015	-	
$\Delta I P$ reference	4750 6015	4750 8015	
IEC 60664-1 insulation coordination			
Insulation voltage	800 V		
Surge voltage	8 kV		
Degree of pollution	III		
Measurement circuit			
Rated primary current	10 A	1 A	
Rated secondary current	0.0167 A	0.000125 A	
Winding ratio K_n	10/0.0167	1/0.000125	
$\Delta I C$ rated load	Max 47 Ω	-	
$\Delta I P$ rated load	Max 180 Ω	Max 2400 Ω	
$\Delta I C$ rated output (under maximum operating conditions)	0.02 VA	-	
$\Delta I P$ rated output (under maximum operating conditions)	0.05 VA	0.05 VA	
Frequency domain	42 – 3 KHz	42 – 3 KHz	
Secondary protection by Transil diode	Yes	Yes	
$I_{\Delta n}$ setting range recommended if there are pulsed DC current components	30mA to 3A	30mA to 3A	
Environment			
Operating temperature	-25°C..+70°C		
Storage temperature	-25°C..+70°C		
Climatic class - Mechanical conditions as per IEC 60721	3K5/3M4		
Transport IEC 60721-3-2	2K5/2M2		
IEC 60721-3-1 long-term storage	1K5/1M3		
Connection/Wiring			
Connection type			
Flexible/rigid cross-section	0.2..2.5mm ² /0.14mm ² ...1.5mm ²		
Stripping length	6mm		
DLD connection distance			
Single wire ≥ 0.75 mm ²	0..1m		
Twisted single wire ≥ 0.75 mm ²	0..10m		
Shielded cable ≥ 0.75 mm ²	0..40m		
Recommended cable (shielding, shielding connected in a single location (terminal I), no earth connection)	J-Y(STY)min 2x0.8		
Other features			
Internal IP rating	IP40		
Terminal block IP rating	IP20		
Flammability class	M5		
Product standards	IEC60044-1		
Homologation (pending)	UL1053		
Centring device		-	
Bracket		4750 8015	
Sealable cover		-	
DIN rail mounting kit		4950 0031	
Spare detachable screw terminal block		-	
Spare detachable push-in terminal block		-	

	Ø30	Ø15/8	Ø 50	Ø 80	Ø 120	Ø 200	Ø 300
	4950 6030	-	4950 6050	4950 6080	4950 6120	4950 6200	4950 6300
	4750 6030	4750 8030	4750 6050	4750 6080	4750 6120	4750 6200	4750 6300
	800 V 8 kV III		800 V 8 kV III	800 V 8 kV III	800 V 8 kV III	800 V 8 kV III	800 V 8 kV III
	10 A 0.0167 A 10/0.0167 Max 47 Ω Max 180 Ω 0.02 VA 0.05 VA 42 – 3 KHz Yes 30mA to 3A	1 A 0.000125 A 1/0.000125 - Max 2400 Ω - 0.05 VA 42 – 3 KHz Yes 30mA to 3A	10 A 0.0167 A 10/0.0167 Max 47 Ω Max 180 Ω 0.02 VA 0.05 VA 42 – 3 KHz Yes 30mA to 3A	10 A 0.0167 A 10/0.0167 Max 47 Ω Max 180 Ω 0.02 VA 0.05 VA 42 – 3 KHz Yes 30mA to 5A	10 A 0.0167 A 10/0.0167 Max 47 Ω Max 180 Ω 0.02 VA 0.05 VA 42 – 3 KHz Yes 30mA to 5A	10 A 0.0167 A 10/0.0167 Max 47 Ω Max 180 Ω 0.02 VA 0.05 VA 42 – 3 KHz Yes 30mA to 5A	10 A 0.0167 A 10/0.0167 Max 47 Ω Max 180 Ω 0.02 VA 0.05 VA 42 – 3 KHz Yes 30mA to 10A
	-25°C..+70°C -25°C..+70°C		-25°C..+70°C -25°C..+70°C	-25°C..+70°C -25°C..+70°C	-25°C..+70°C -25°C..+70°C	-25°C..+70°C -25°C..+70°C	-25°C..+70°C -25°C..+70°C
	3K5/3M4 2K5/2M2 1K5/1M3		3K5/3M4 2K5/2M2 1K5/1M3	3K5/3M4 2K5/2M2 1K5/1M3	3K5/3M4* 2K5/2M2 1K5/1M3	3K5/3M4 2K5/2M2 1K5/1M3	3K5/3M4* 2K5/2M2 1K5/1M3
	0.2..2.5mm ² 8...9mm 0...1m 0...10m 0...40m J-Y(ST)Ymin 2x0.8	0.2..2.5mm ² 8...9mm 0...1m 0...10m 0...40m J-Y(ST)Ymin 2x0.8	0.2..2.5mm ² 8...9mm 0...1m 0...10m 0...40m J-Y(ST)Ymin 2x0.8	0.2..2.5mm ² 8...9mm 0...1m 0...10m 0...40m J-Y(ST)Ymin 2x0.8	0.2..2.5mm ² 8...9mm 0...1m 0...10m 0...40m J-Y(ST)Ymin 2x0.8	0.2..2.5mm ² 8...9mm 0...1m 0...10m 0...40m J-Y(ST)Ymin 2x0.8	0.2..2.5mm ² 8...9mm 0...1m 0...10m 0...40m J-Y(ST)Ymin 2x0.8
	IP40 IP20 M5 IEC60044-1 UL1053		IP40 IP20 M5 IEC60044-1 UL1053	IP40 IP20 M5 IEC60044-1 UL1053	IP40 IP20 M5 IEC60044-1 UL1053	IP40 IP20 M5 IEC60044-1 UL1053	IP40 IP20 M5 IEC60044-1 UL1053
	4950 0011		4950 0012	4950 0013	4950 0014	-	-
	4950 0001		4950 0002	4950 0003	4950 0003	4950 0004	4950 0005
	4950 0020		4950 0020	4950 0020	4950 0020	4950 0020	4950 0020
	4950 0031		4950 0031	4950 0031	4950 0031	-	-
	4950 0041		4950 0041	4950 0041	4950 0041	4950 0041	4950 0041
	4950 0040		4950 0040	4950 0040	4950 0040	4950 0040	4950 0040

* with mounting bracket



539 541 B - EN - 12/12

HEAD OFFICE

SOCOMEK GROUP

S.A. SOCOMEK capital 10 951 300 €
R.C.S. Strasbourg B 548 500 149
B.P. 60010 - 1, rue de Westhouse
F-67235 Benfeld Cedex - FRANCE

INTERNATIONAL SALES DEPARTMENT

SOCOMEK

1, rue de Westhouse - B.P. 60010
F - 67235 Benfeld Cedex - FRANCE
Tel. +33 (0)3 88 57 41 41
Fax +33 (0)3 88 74 08 00
info.scp.isd@socomec.com

www.socomec.com

