

Type 1 – Charging Cable



Specification Type 1 – Charging Connector + Charging Cable

Product Definition

Charging standard	Type 1
Standards / regulations	IEC 62196-2 SAE J1772
Approval	UL
Country approval	On request
Confection line end	On request

Dimensions Charging Connector

Width	55,5 mm
Height	121 mm
Depth	222 mm
Conductor length	On request

Ambient Conditions

Ambient temperature (operation)	-30°C ... +50°C
Ambient temperature (storage/transport)	-40°C ... +80°C
Max. altitude	5.000 m (above sea level)
Degree of protection (plugged)	IP44
Degree of protection (protective cap)	IP44



Electrical Properties

Number of phases	1			
Rated voltage for power contacts	250 V AC			
Rated current for power contacts	16 A	41 A	50 A	80 A
Maximum charging power	4 kW	10 kW	12,5 kW	20 kW
Number of power contacts	3 (L1, N, PE)			
Rated voltage for signal contacts	30 V AC			
Rated current for signal contacts	2 A			
Number of signal contacts	2 (CP, PP)			
Note on the connection method	Crimp termination (cannot be disconnected)			
Resistor coding (between PE and CS)	480 Ω (lever operated) 150 Ω (lever not operated)			

Mechanical Properties

Mating cycles	> 10.000
Insertion force	< 75 N
Withdrawal	< 75 N

Design

Color housing / handle area	black
Color mating face / locking lever	black
Color protective cap	black
Housing with customer logo	On request

Material

Material housing / handle area	Plastic
Material mating face	Plastic
Material protective cap	Soft plastic
Flammability rating	V0
Material contacts	Cu-Alloy
Material surface of contacts	Ag



Cable

Cable structure	1 phase			
	16 A	41 A	50 A	80 A
	3 x 2,1 mm ² + 0,56 mm ²	3 x 5,3 mm ² + 0,56 mm ²	3 x 8,5 mm ² + 0,82 mm ²	2 x 13,2 mm ² + 8,5 mm ² + 0,82 mm ²
Cable diameter	10,5 ± 0,3 mm	15,9 ± 0,3 mm	22,4 ± 0,3 mm	24,0 ± 0,3 mm
Cable resistance at 20°C (2,1 mm ²)	≤ 8,88 Ω/km			
Cable resistance at 20°C (5,3 mm ²)	≤ 3,51 Ω/km			
Cable resistance at 20°C (8,5 mm ²)	≤ 2,23 Ω/km			
Cable resistance at 20°C (13,2 mm ²)	≤ 1,40 Ω/km			
Cable resistance at 20°C (0,56) mm ²)	≤ 35,7 Ω/km			
Cable resistance at 20°C (0,82 mm ²)	≤ 22,4 Ω/km			
Wiring standard	UL 62 - EVE			
Type of conductor	Straight, more types on request			
Outer sheath, material	TPE-U			
Outer sheath, color	On request			
Minimum bending radius	9 x cable diameter			

Environmental Product Compliance

REACH SVHC	Lead CAS 7439-92-1
China RoHS	Environmentally Friendly Use Period: 50 years

Drawings

Dimensional drawing

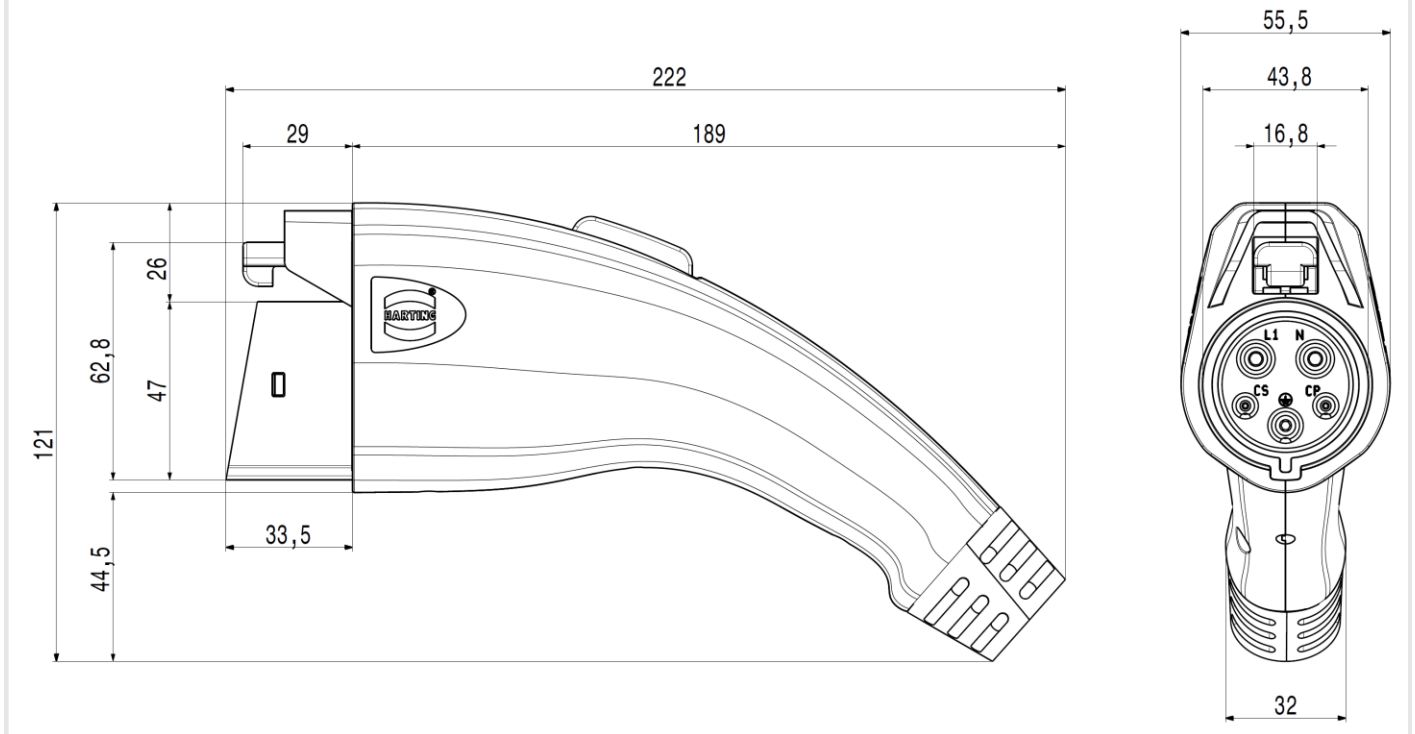

Pin assignment of the vehicle connector

