

PRODUCT NUMBER
69167-XXXXXXHLF

- LEAD FREE OPTION
NOTE 1, 2, 7
- POLARIZATION
NOTE 10
- NO. OF POS.
SEE TABLE
- PIN PLATING
- BASE P/N

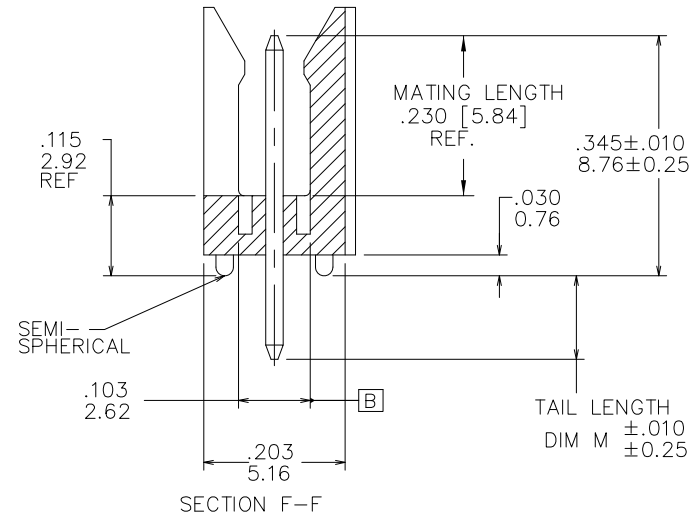
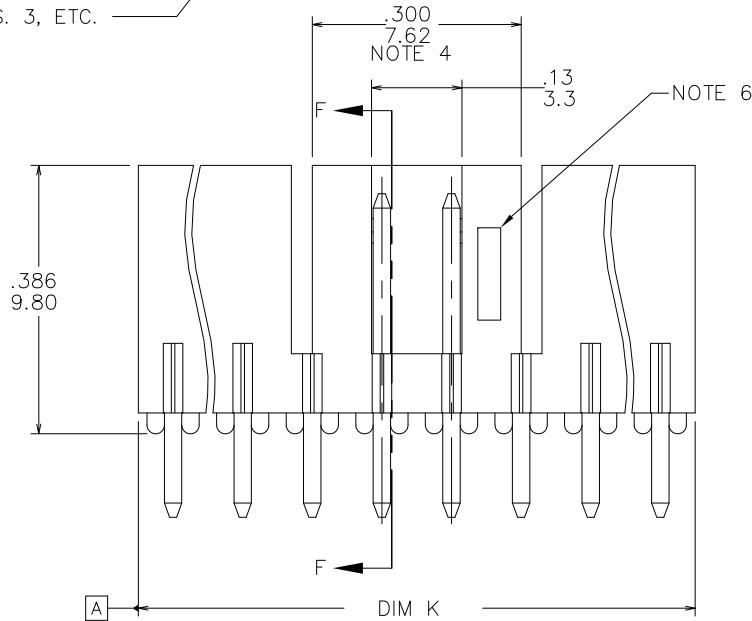
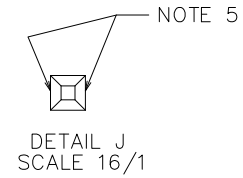
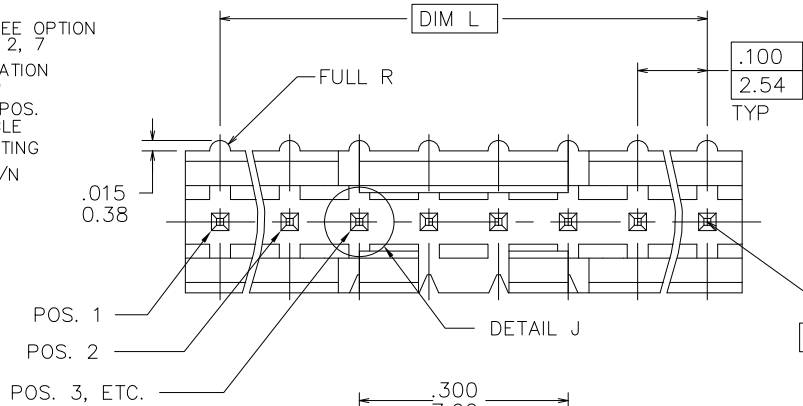

Amphenol FCI

© 2016 AFCI

Mat'l. code NOTES 1 & 2		surface ISO 1302 ✓		tolerance ISO 406 ISO 1101		projection inch/mm		product family		
ltr	ecn no	dr	date	tolerances unless otherwise specified		inch/mm		title		
T	ELX-N-01896	JZ	05/31/12	angles	XXX.0/XXX.3	scale 1:1		FRICION LATCH HEADER SINGLE ROW VERTICAL		
U	ELX-N-20592	J.H	03/30/15	linear	XXX.0/XXX.013					
V	ELX-N-37212	M.Z	05/29/20	0±2°	XXX.0.020 XXX.0.051					
W	ELX-N-44959	M.X	06/06/22	dr	M.CLOUSER	11/27/90	dwg no		sheet 1 of 3	size
				enr	C.TREXTLER	11/27/90	69167		A3	
				chr	C.TREXTLER	11/27/90	type Product Customer		Drawing	
				appd	C.TREXTLER	11/27/90				
sheet index	revision sheet	W	W	W						
		1	2	3						

PRODUCT NUMBER	NO OF POS	DIM K	DIM L	TAIL LENGTH DIM M
69167-X03	1 X 3	.300/7.62	.200/5.08	.120/3.05
69167-X04	1 X 4	.400/10.16	.300/7.62	.120/3.05
69167-X05	1 X 5	.500/12.70	.400/10.16	.120/3.05
69167-X06	1 X 6	.600/15.24	.500/12.70	.120/3.05
69167-X07	1 X 7	.700/17.78	.600/15.24	.120/3.05
69167-X08	1 X 8	.800/20.32	.700/17.78	.120/3.05
69167-X09	1 X 9	.900/22.86	.800/20.32	.120/3.05
69167-X10	1 X 10	1.000/25.40	.900/22.86	.120/3.05
69167-X11	1 X 11	1.100/27.94	1.000/25.40	.120/3.05
69167-X12	1 X 12	1.200/30.48	1.100/27.94	.120/3.05
69167-X13	1 X 13	1.300/33.02	1.200/30.48	.120/3.05
69167-X14	1 X 14	1.400/35.56	1.300/33.02	.120/3.05
69167-X15	1 X 15	1.500/38.10	1.400/35.56	.120/3.05
69167-X16	1 X 16	U N A V A I L A B L E		
69167-X17	1 X 17	U N A V A I L A B L E		
69167-X18	1 X 18	U N A V A I L A B L E		
69167-X19	1 X 19	U N A V A I L A B L E		
69167-X20	1 X 20	U N A V A I L A B L E		
69167-X21	1 X 21	U N A V A I L A B L E		
69167-X22	1 X 22	U N A V A I L A B L E		
69167-X23	1 X 23	U N A V A I L A B L E		
69167-X24	1 X 24	U N A V A I L A B L E		
69167-X25	1 X 25	U N A V A I L A B L E		
69167-X26	1 X 26	U N A V A I L A B L E		
69167-X27	1 X 27	U N A V A I L A B L E		
69167-X28	1 X 28	U N A V A I L A B L E		
69167-X29	1 X 29	U N A V A I L A B L E		
69167-X30	1 X 30	U N A V A I L A B L E		
69167-X31	1 X 31	U N A V A I L A B L E		
69167-X32	1 X 32	U N A V A I L A B L E		
69167-X33	1 X 33	U N A V A I L A B L E		
69167-X34	1 X 34	U N A V A I L A B L E		
69167-X35	1 X 35	U N A V A I L A B L E		
69167-X36	1 X 36	U N A V A I L A B L E		

PIN PLATING CODES	
XXXX-1YY	30u"/0.76u MIN (SEE NOTE 8) OVER 50u"/1.27u MIN Ni
XXXX-2YY	15u"/0.38u MIN (SEE NOTE 8) OVER 50u"/1.27u MIN Ni
XXXX-3YY	50u"/1.27u MIN (SEE NOTE 8) OVER 50u"/1.27u MIN Ni
XXXX-4YY	100u"/2.54u MIN Sn OVER 50u"/1.27u MIN Ni (SEE NOTE 9)
XXXX-4YYHLF	
XXXX-5YY	15u"/0.38u MIN (SEE NOTE 8) OVER 50u"/1.27u MIN Ni
XXXX-6YY	30u"/0.76u MIN (SEE NOTE 8) OVER 50u"/1.27u MIN Ni
XXXX-7YY	30u"/0.76u MIN (SEE NOTE 8) OVER 50u"/1.27u MIN Ni
XXXX-8YY	15u"/0.38u MIN (SEE NOTE 8) OVER 50u"/1.27u MIN Ni

NOTES:

- PART NUMBER OPTIONS:
PIN PLATING CODES (SEE ABOVE)
LEAD FREE:
ADD "HLF" AT THE END OF PART NUMBER FOR LEAD FREE OPTION, NOT AVAILABLE FOR -5YY, -5YYH, -6YY, -6YYH.
- BODY MATERIAL:
GLASS REINFORCED HTN COLOR: BLACK
FLAME RETARDANT PER UL 94 V-0
MAXIMUM OPERATING TEMPERATURE: 130° C
OR
MINERAL FILLED LCP, COLOR BLACK
FLAME RETARDANT PER UL 94 V-0

PART NUMBERS WITH "H" SUFFIX WILL WITHSTAND EXPOSURE TO 260°C PEAK TEMPERATURE FOR 20 SECONDS IN WAVE SOLDER, INFRA-RED OR VAPOR PHASE SOLDER PROCESS.

PART NUMBERS WITHOUT "H" SUFFIX WILL WITHSTAND EXPOSURE TO 260°C PEAK TEMPERATURE FOR WAVE SOLDER PROCESS.
- PIN MATERIAL: 3/4 HARD PHOS-BRONZE.
- NO SLOTS ON 1 X 5 POSITION OR SMALLER PRODUCT. THE CENTER KEY SLOT WILL BE ON ALL HEADERS REGARDLESS OF SIZE.
- TWO NON-CRITICAL SIDES OF PIN TIP NOT PLATED, BOTH ENDS
- COMPANY LOGO MAY APPEAR IN THIS AREA.
- THESE PRODUCTS MEET EUROPEAN UNION DIRECTIVES AND OTHER COUNTRY REGULATION AS DESCRIBED IN GS-22-008.
- PLATING OPTIONS:
PERFORMANCE PLATING WILL BE EITHER GOLD OR GXT ON CONTACT OR TAIL, OPTIONALLY (78~295u"/2~7.5u) TIN ON TAIL.
- "THIS PRODUCT HAS 100% TIN PLATING IN THE INTERFACE AND HAS NOT BEEN TESTED FOR WHISKER GROWTH IN ALL INTERCONNECT ENVIRONMENTS."
- FOR POLARIZATION, SPECIFY POSITION NUMBER (i.e. A03=ROW A POSITION 03) TO OMIT PIN.
OMIT FROM PRODUCT NUMBER IF THIS FEATURE IS NOT APPLICABLE.
PRODUCT MANAGEMENT APPROVAL REQUIRED PRIOR TO RELEASE OR SALE OF POLARIZED PRODUCT.

Amphenol FCI

© 2016 AFCI

Mat'l code	surface	tolerance	projection	product family
NOTES 1 & 2	ISO 1302 ✓	ISO 406 ISO 1101		
ltr	ecn no	dr	date	title
				FRICION LATCH HEADER SINGLE ROW VERTICAL
w	angles	linear	inch/mm	scale 1:1
	0±2°	XXX.0/XXX.03 XXX.006/XXX.013 XXX.0020 XXX.005		
dr	M.CLOUSER	11/27/90		dwg no
enr	C.TREXTLER	11/27/90		sheet 2 of 3
chr	C.TREXTLER	11/27/90		69167
appd	C.TREXTLER	11/27/90		size A3
sheet index	revision sheet			type Product Customer Drawing

PRODUCT NUMBER	NO OF POS	DIM K	DIM L	TAIL LENGTH DIM M	POLARIZATION PIN POSITION
69167-X43	1 X 3	.300/7.62	.200/5.08	.190/4.83	
69167-X44	1 X 4	.400/10.16	.300/7.62	.190/4.83	
69167-X45	1 X 5	.500/12.70	.400/10.16	.190/4.83	
69167-X46	1 X 6	.600/15.24	.500/12.70	.190/4.83	
69167-X47	1 X 7	.700/17.78	.600/15.24	.190/4.83	
69167-X48	1 X 8	.800/20.32	.700/17.78	.190/4.83	
69167-X49	1 X 9	.900/22.86	.800/20.32	.190/4.83	
69167-X50	1 X 10	1.000/25.40	.900/22.86	.190/4.83	
69167-X51	1 X 11	1.100/27.94	1.000/25.40	.190/4.83	
69167-X52	1 X 12	1.200/30.48	1.100/27.94	.190/4.83	
69167-X53	1 X 13	1.300/33.02	1.200/30.48	.190/4.83	
69167-X54	1 X 14	1.400/35.56	1.300/33.02	.190/4.83	
69167-X55	1 X 15	1.500/38.10	1.400/35.56	.190/4.83	
69167-X56	1 X 16	U N A V A I L A B L E			
69167-X57	1 X 17	U N A V A I L A B L E			
69167-X58	1 X 18	U N A V A I L A B L E			
69167-X59	1 X 19	U N A V A I L A B L E			
69167-X60	1 X 20	U N A V A I L A B L E			
69167-X61	1 X 21	U N A V A I L A B L E			
69167-X62	1 X 22	U N A V A I L A B L E			
69167-X63	1 X 23	U N A V A I L A B L E			
69167-X64	1 X 24	U N A V A I L A B L E			
69167-X65	1 X 25	U N A V A I L A B L E			
69167-X66	1 X 26	U N A V A I L A B L E			
69167-X67	1 X 27	U N A V A I L A B L E			
69167-X68	1 X 28	U N A V A I L A B L E			
69167-X69	1 X 29	U N A V A I L A B L E			
69167-X70	1 X 30	U N A V A I L A B L E			
69167-X71	1 X 31	U N A V A I L A B L E			
69167-X72	1 X 32	U N A V A I L A B L E			
69167-X73	1 X 33	U N A V A I L A B L E			
69167-X74	1 X 34	U N A V A I L A B L E			
69167-X75	1 X 35	U N A V A I L A B L E			
69167-X76	1 X 36	U N A V A I L A B L E			
69167-X77	1 X 10	1.000/25.40	.900/22.86	.120/3.05	2/3/5/6/8/9
69167-X78	1 X 4	.400/10.16	.300/7.62	.120/3.05	2/3
69167-X79	1 X 3	.300/7.62	0.200/5.08	.120/3.05	2
69167-X80	1 X 7	.700/17.78	0.600/15.24	.120/3.05	2/3/5/6
69167-X83	1 X 3	.300/7.62	0.200/5.08	0.165/4.19	

Mat'l. code NOTES 1 & 2		surface ISO 1302 ✓	tolerance ISO 406 ISO 1101	projection 	product family
ltr	ecn no	dr	date	tolerances unless otherwise specified	title FRICION LATCH HEADER SINGLE ROW VERTICAL
w				linear XXX.X/XXX.3 XXX.X/XXX.13 XXX.X/XXX.05	
				0±2°	inch/mm ↔
					scale 1:1
		dr	M.CLOUSER	11/27/90	dwg no 69167 sheet 3 of 3 size A3
		enr	C.TREXTLER	11/27/90	
		chr	C.TREXTLER	11/27/90	
		appd	C.TREXTLER	11/27/90	
sheet index	revision sheet				type Product Customer Drawing

Amphenol FCI

© 2016 AFCI