



D38999/23

Jam Nut Mount Hermetic Receptacle

MIL-DTL-38999 Series III

How To Order: MS

B

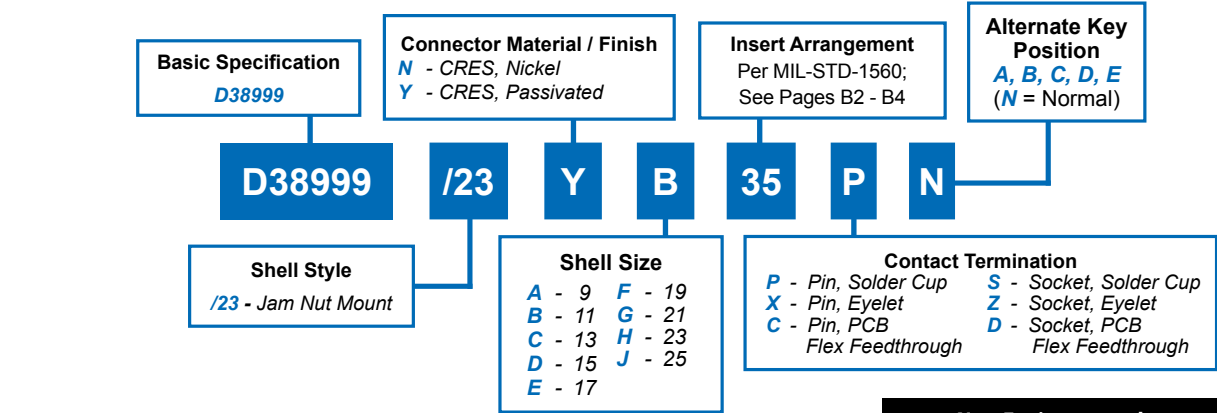

**Non-Environmental
Rear Accessory Thread Adapter
Available for this Receptacle
See P/N 980-002 on Page B-90**

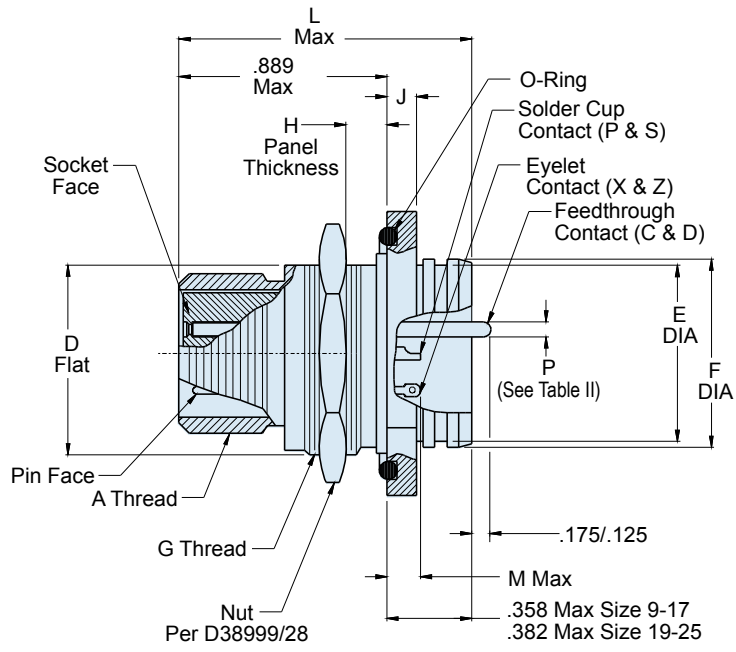
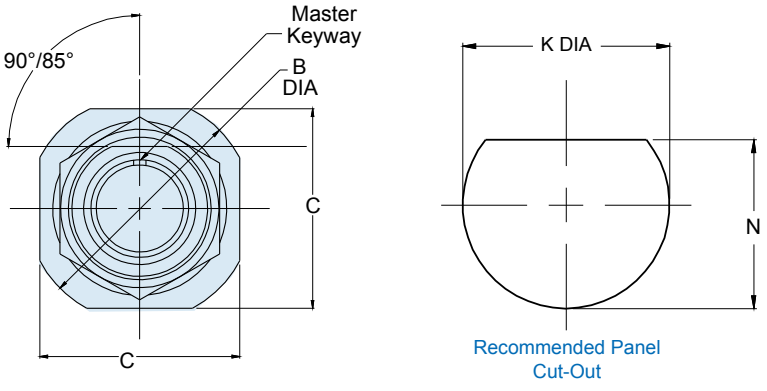

TABLE II: CONTACT SIZE

PRINTED CIRCUIT TAIL CONFIGURATIONS
CONTACT STYLE C AND D

Contact Size	ø P
22D	.011 (0.28) .015 (0.38)
20	.024 (0.61) .028 (0.71)
16	.0635 (1.61) .0615 (1.56)
12	.095 (2.41) .093 (2.36)



WIRE ACCOMODATION

Contact Size	Wire Guage
22D	#22 - #28
20	#20 - #24
16	#16 - #20
12	#12 - #14

Dimensions in Inches (millimeters) are subject to change without notice.