

# CMS 444 Series 5MM Round Threaded Plain Lens With Seal



5mm Round standard threaded plain lens with seal

## Notes

**MOUNTING:** Mounts in a  $\text{Ø}.312\pm.002$  [ $\text{Ø} 7.92\text{mm}\pm.05$ ] panel hole on  $.500$  [ $12.7\text{mm}$ ] centers. Panel thickness  $.031$  [ $.8\text{mm}$ ] to  $.125$  [ $3.18\text{mm}$ ]. Panel hole should be deburred, but not chamfered.

**ASSEMBLY:** Insert lens through panel hole, slide lock washer onto lens barrel and twist on retaining ring. PCB mounted LEDs slide into lens when the panel cover is closed or the PCB card is inserted into the case.

### MATERIAL:

Lens-Polycarbonate, UL 94-V2

Lock Washer- CR Steel, Nickel plate

Retaining ring - Thermoplastic, U.L. 94-HB

Seal- EPDM

This is an assembly that used the RTN\_441 retainer ring

Max torque nut should be tightened to is 1.8lb-in. (Product begins to fail at 3.2lb-in.)

U.S. & Foreign Pat. Issued & Pend.

## Product Dimensions

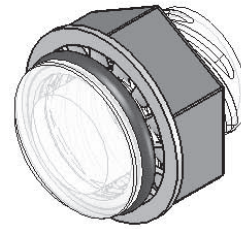
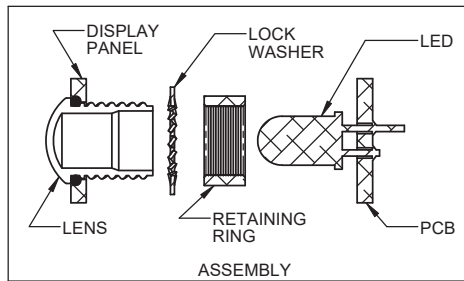
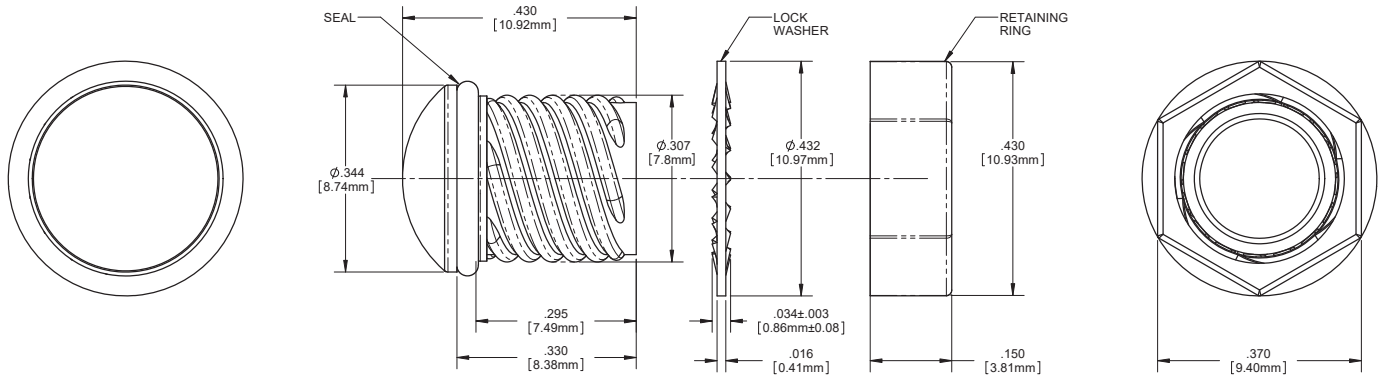

## Ordering Data

ORDERING CODE : CMS 444 XXX

MODEL

LENS COLOR	
RTP	RED TRANSPARENT
ATP	AMBER TRANSPARENT
GTP	GREEN TRANSPARENT
BTP	BLUE TRANSPARENT
YTP	YELLOW TRANSPARENT
CTP	CLEAR TRANSPARENT

## Compliances and Approvals



# Mouser Electronics

Authorized Distributor

Click to View Pricing, Inventory, Delivery & Lifecycle Information:

VCC:

[CMS444CTP](#) [CMS\\_444\\_CTP](#)