



# D38999/27

## Weld Mount Hermetic Receptacle

### MIL-DTL-38999 Series III

#### How To Order: MS

**B**

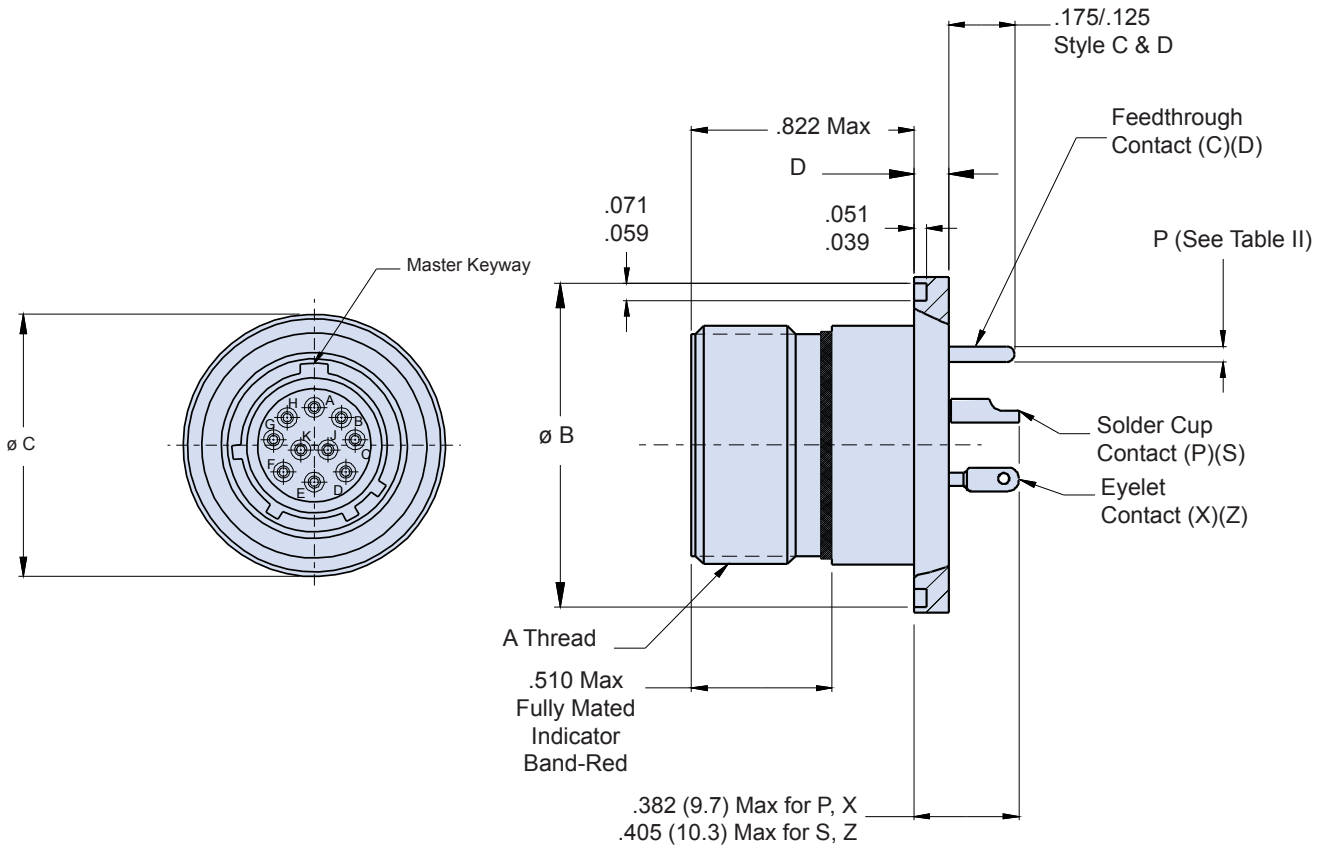
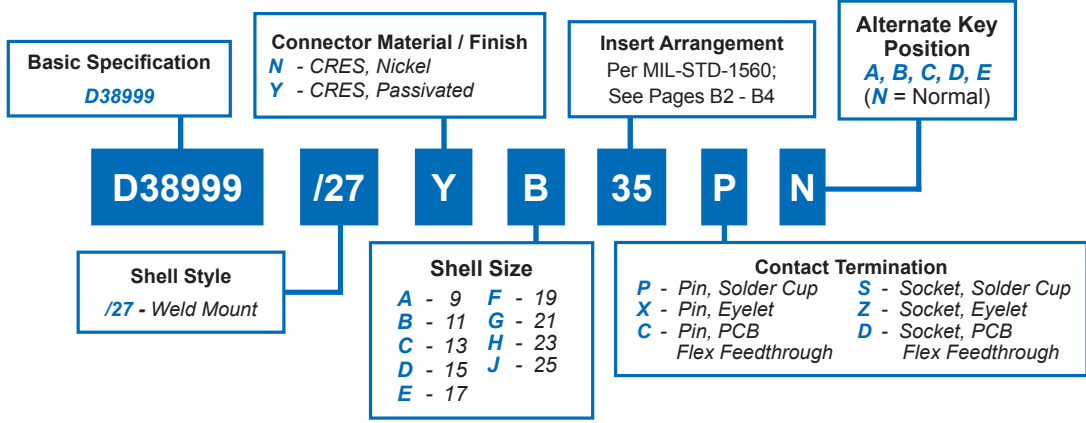

Consult Factory for Recommended Panel Cutout Dimensions

Dimensions in Inches (millimeters) are subject to change without notice.