

PRODIN RANGE PANEL METERS

DESCRIPTION 72 x 72mm DIN sized panel meter with a horizontal scale and a round barrel.

Manufactured to IEC51.

APPLICATION Used widely in the panel building industry, where a DIN product with a horizontal scale is required. Round barrel allows straightforward installation without special tools.



PD72SD MOVING IRON - AC

Rating	Burden	Accuracy Class
Scaled up to 40A direct connected	1.2VA max up to 30A, 2.4VA up to 40A	1.5
1A or 5A CT operated, scaled as necessary	0.7VA typically at 50Hz	1.5
Scaled 30V to 600V, direct connected	6VA max	1.5

PD72HZ FREQUENCY RANGES

Rating	Burden	Accuracy Class
45/65, 45/55 or 55/65 Hz for 110/230/380V direct connected	6mA at nominal voltage	1.5

PD72MC MOVING COIL - DC

Rating	Burden	Accuracy Class
100µA to 40A direct connected	up to 150mV	1.5
4/20mA, scaled as necessary	up to 150mV	1.5
Scaled up to 600V, direct connected	1mA (1000Ω/V)	1.5
50mV to 300mV shunt operated, scaled as necessary	1mA (1000Ω/V)	1.5

Specifications

Flame retardant: Base - UL94V1, Case - UL94V0

Protection: IP52 (front of panel)

Scale marking: DIN 43802

Overload (A): 1.2 x rating 2hrs / 10 x rating 5 seconds

Overload (V): 1.2 x rating 2hrs / 2 x rating 5 seconds

Insulation test: 2kV 50Hz for 1 minute

Temperature: Calibrated at 23°C, suitable for -25 to +40°C

Terminals: M4 screw clamps supplied as standard
(above 5A, M6 studs are supplied)

Panel mounting: U-clamp fixing or 2 pin fixing (57mm or 53mm)

Options

- Special scales
- M6 terminals, M3 studs
- 6.4mm faston tags (up to 5A)
- Terminal cover

Dimensions (mm)

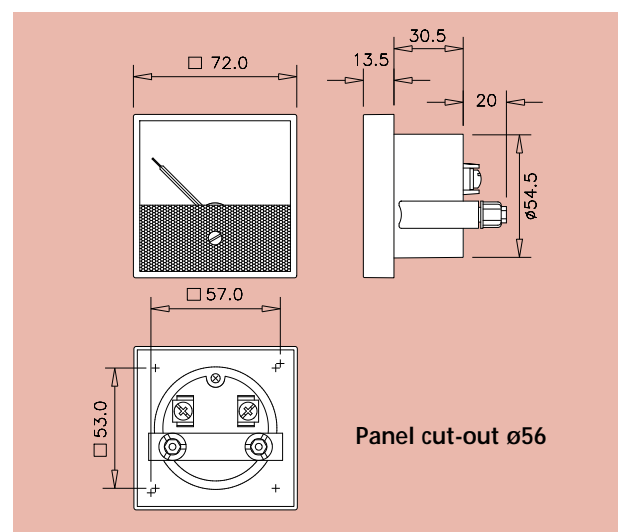

Our policy is one of continuous development and therefore specifications may change without notice.

HOWARD BUTLER LTD

CROWN WORKS, LINCOLN ROAD
WALSALL WS1 2EB ENGLAND

Tel: 01922 640003 Fax: 01922 723626

International Tel: +44 1922 640003 E-mail: sales@hobut.co.uk

<http://www.hobut.co.uk>