



MCDP6000

USB Type-C DP Alt-Mode Switching Retimer

Kinetic Technologies cannot assume responsibility for use of any circuitry other than circuitry entirely embodied in a Kinetic Technologies product. No intellectual property or circuit patent licenses are implied. Kinetic Technologies reserves the right to change the circuitry and specifications without notice at any time.

Contents

- 1. Description 8
- 2. Application Overview 9
- 3. Functional Description 10
 - 3.1. System Block Diagram 10
 - 3.2. MCDP6000 Block Diagram 11
 - 3.3. Receiver PHY 12
 - 3.4. Transmitter PHY 13
 - 3.5. DisplayPort Receiver Interface 14
 - 3.6. AUX_CH, SBU Interface for DisplayPort Alternate Mode 15
 - 3.6.1. AUX_CH latency mode 16
 - 3.7. USB 3.2 x1 Interface 17
 - 3.8. USB Type-C Connector Facing Interface 17
 - 3.9. IC Operation 18
 - 3.9.1. Bootstrap 18
 - 3.9.2. IC Top-Level State Machine 20
 - 3.9.3. TWI Programmable Mode 21
 - 3.9.4. Stand-Alone Mode 21
 - 3.9.5. Low Power Mode 21
 - 3.9.6. USB 3.2 x1 Retimer Operation 21
 - 3.9.7. DisplayPort Retimer Operation 23
 - 3.10. Power Supply 24
 - 3.11. Power Consumption 24
 - 3.12. System Interface 25
 - 3.12.1. TWI 25
 - 3.12.2. XTAL Buffer Operation 27
 - 3.12.3. Reference Clock Input 28
 - 3.12.4. Reference Clock Output 28

4. Pin Description	30
5. Package Specification	34
5.1. Package Drawing and Dimensions	34
6. Marking Field Template and Descriptors	35
7. Electrical Specifications	36
7.1. Absolute Maximum Ratings	36
7.2. ESD and Latch-up ratings.....	36
7.3. Thermal Capabilities	36
7.4. Recommended Operating Conditions.....	37
7.5. Electrical Characteristics.....	37
7.5.1. DC characteristics.....	37
7.5.2. DisplayPort transmitter	38
7.5.3. DisplayPort receiver.....	40
7.5.4. DisplayPort AUX_CH.....	41
7.5.5. USB 3.2 x1 transmitter.....	42
7.5.6. USB 3.2 x1 receiver	43
7.5.7. TWI Timing.....	44
8. Ordering Information	44
9. References	44

List of Tables

Table 1.	DP1.4a Repeater Mode	8
Table 2.	DP transmitter configuration	13
Table 3.	SSC source in each operation mode	14
Table 4.	AUX_CH latency mode	16
Table 5.	0x350 register definition.....	16
Table 6.	MCDP6000 Bootstrap operation.....	18
Table 7.	MCDP6000 Bootstrap for AUX_CH latency mode	18
Table 8.	Operation mode configuration register	19
Table 9.	MCDP6000 Operating Mode	20
Table 10.	Power Consumption (Preliminary estimation in typical conditions).....	24
Table 11.	TWI Device ID Configuration	25
Table 12.	Recommended Crystal Specifications	27
Table 13.	Recommended Reference Clock Input Characteristics.....	28
Table 14.	Reference Clock Output Characteristics	28
Table 15.	Reference Clock Configuration Register Definition	29
Table 16.	Pin Description.....	31
Table 17.	Field Descriptors.....	35
Table 18.	Absolute Maximum Ratings	36
Table 19.	ESD and Latch-up Ratings	36
Table 20.	Thermal Capabilities	36
Table 21.	Recommended Operating Conditions	37
Table 22.	DC Characteristics.....	37
Table 23.	DisplayPort transmitter characteristics	38
Table 24.	DisplayPort receiver characteristics	40
Table 25.	USB 3.2 x1 transmitter characteristics	42
Table 26.	USB 3.2 x1 receiver characteristics.....	43
Table 27.	TWI Timing.....	44

List of Figures

Figure 1.	MCDP6000 System Block Diagram.....	7
Figure 2.	MCDP6000 Motherboard-Down Use Case	9
Figure 3.	MCDP6000 System Block Diagram.....	10
Figure 4.	MCDP6000 Block Diagram.....	11
Figure 5.	FSM Based Eye Scan Concept	12
Figure 6.	Example Output of Software Based Eye Scan	13
Figure 7.	AUX – SBU channel topology.....	15
Figure 8.	MCDP6000 Operation Mode State Machine	20
Figure 9.	Write Access	26
Figure 10.	Read Access.....	26
Figure 11.	Internal Oscillator with an External Crystal.....	27
Figure 12.	Cascading Reference Clock Across Multiple MCDP6000	29
Figure 13.	MCDP6000 Ex-VQFN46 Pin Assignment (Top-View).....	30
Figure 14.	MCDP6000 Ex-VQFN46 Package Outline Drawing (unit: mm).....	34
Figure 15.	MCDP6000 Ex-VQFN46 Marking Template.....	35

Features

- Integrated USB Type-C DisplayPort alternate mode lane switch to support
 - Flip-ability of USB Type-C
 - Simultaneous USB 3.2 x1 Enhanced SuperSpeed (ESS) and 2 lane DP1.4a
 - 4/2/1-Lane DP1.4a(RBR/HBR/HBR2/HBR3)
- Power Supply Voltages
 - 1.8 V for I/O, 1.2 V for core
- USB3.2 Appendix.E x1 Compliant Retimer
 - 5 Gbps and 10 Gbps support
 - Link training participation
 - Spread-spectrum clocking as per USB 3.2 standard
 - LFPS polling and processing
 - LFPS Based PWM support
 - Pass-Through / Local loopback
 - Loopback BERT for USB 3.2 SS
 - Lane polarity inversion
 - BLR (Bit-Level Retimer) for SS mode
 - Low latency data path
 - Link layer snooping
 - Link power management support
 - SRIS (Separate Reference clock Independent SSC) for SSP mode
 - 128b/132b coding
 - Scrambler / De-scrambler
 - Link power management support
 - SKP OS handling / Elastic buffer for USB for clock offset compensation
 - DC balance tracking / control
 - Error correction
 - Transmitter Emphasis
 - 3-tap FIR TXEQ for SSP
 - 2-tap TXEQ for SS
 - Adaptive Receiver Equalization
 - DFE + CTLE for SSP to support -23dB insertion loss compensation @5GHz
 - CTLE for SS to support -20dB insertion loss compensation @2.5GHz
- DP1.4a Compliant Repeater
 - Data rate 1.62 Gbps / 2.7 Gbps / 5.4 Gbps / 8.1 Gbps
 - Transparent mode / Non-transparent mode support
 - AUX_CH transaction snooping
 - DP1.4a Compliant Retimer DPCD registers
 - 8b/10b coding
 - Pattern generator and Error Checker
 - Down-spreading of link clock
 - Error detection
 - Adjustable TXEQ during the link training through AUX_CH
 - Adaptive equalizer with CTLE and DFE
 - DFE + CTLE for HBR3 to compensate -27dB insertion loss @4.05GHz
 - CTLE for HBR2 / HBR / RBR
 - Support of custom PHY configuration through TWI
- Real time Eye Opening Monitor (EOM)
- TWI slave to configure the integrated lane mapping and operation mode
 - Compatible with I²C master
 - Support up to 4 unique TWI device ID
- Configuration pins for the integrated lane switch and operation mode
- Low Power Operation
 - 520 mW in USB 3.2 x1 SSP + Two lanes of DisplayPort HBR3 operation with 1.2 V and 1.8 V power supply
 - 850 μ W in standby mode
- ESD Specification
 - 2kV HBM, \pm 500V CDM
- Package
 - 46 Ex-VQFN (6.5 mm x 4.5 mm)

Applications

- Desktop PC / Notebook / Tablet / Smartphone motherboard enabling USB Type-C DP alternate mode

Figure 1. MCDP6000 System Block Diagram

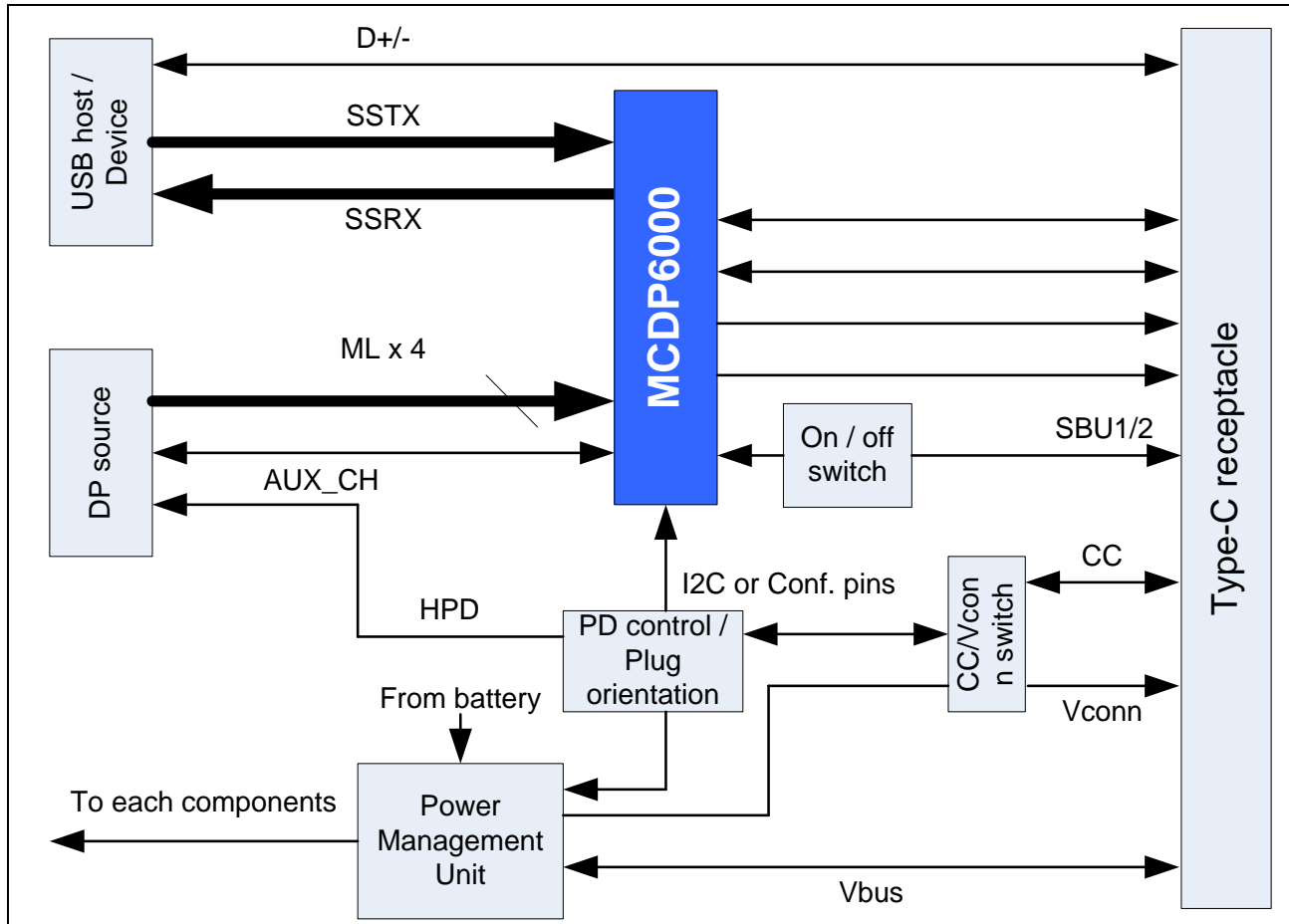

1. Description

The MCDP6000 is a low power USB 3.2 x1 and DisplayPort1.4a repeater device with an integrated USB Type-C switch targeted for desktop / mobile PC motherboard-down application.

The USB 3.2 x1 retimer supports both SuperSpeed (SS) bit rate (5 Gbps), and SuperSpeedPlus (SSP) data rate (10 Gbps). The USB 3.2 x1 retimer includes the link layer function and LTSSM and RTSSM to participate in the link training. The MCDP6000 supports SS mode with a BLR (Bit-Level Retimer) and SSP mode with a SRIS (Separate Reference clock Independent SSC). The MCDP6000 supports link power management with Ux entry and exits in both SS and SSP modes. In addition, the MCDP6000 supports the link state and link quality maintenance, compensates the clock offset between the downstream port and the upstream port, detects errors, and corrects single symbol errors in framing order sets, single bit block header errors, and single or double-bit SKP symbol errors in SSP mode. It also supports spread spectrum clocking (SSC) to minimize EMI and the low frequency periodic signaling (LFPS). The transmitter employs 3-tap FIR-based transmitter equalizer for SSP operation and fixed transmitter equalizer ranging from 3 dB to 4 dB for SS operation. The receiver employs an adaptive Continuous Time Linear Equalizer (CTLE) and a Decision Feedback Equalizer (DFE). Both the transmitter equalizer and the receiver equalizer are configurable through the TWI register. Proper settings to comply with USB 3.2 electrical requirements are provided by default.

The DP1.4a repeater supports 1.62 Gbps, 2.7 Gbps, 5.4 Gbps, and 8.1 Gbps data rates. The following use cases are supported.

Table 1. DP1.4a Repeater Mode

	Mode	AUX_CH Function
LT tunable PHY Repeater	Non-transparent mode	Sample, Manipulate, and Forward to snoop or respond as defined in DP1.4a standard.
	Transparent mode	Sample and Forward to snoop

The DP1.4a repeater implements AUX_CH snooping function of DPCD addresses defined in the standard as well as the LT-tunable PHY Repeater DPCD registers. The DP1.4a repeater can support up to a 0.5% down-spread link rate. The transmitter employs TXEQ, which adjusts its pre-emphasis level according to either the AUX_CH transaction during the link training or the TWI. The receiver employs a fully adaptive Continuous Time Linear Equalizer (CTLE) and Decision Feedback Equalizer (DFE). The transmitter parameter can be set to support the amplitude level and the pre-emphasis level defined in DP1.4a standard are provided in default.

The MCDP6000 operating mode can be configured through the TWI by default. It can be optionally configured through the 3 configuration pins by enabling the feature through TWI. These interfaces can be controlled from an external Power Delivery (PD) controller or microcontroller to set the plug orientation and the pin mapping of the USB Type-C DP Alt-mode. The MCDP6000 operates at 1.8 V and 1.2 V.

The power consumption is:

1. 520 mW with an active 4 lane retimer (USB 3.2 x1 SSP TX/RX and DP 2 lanes HBR3)
2. 850 μ W in stand-by state

The MCDP6000 is offered in a 46-pin, 6.5 mm x 4.5 mm Ex-VQFN package.

2. Application Overview

The target application of MCDP6000 is the Desktop PC / Notebook / Tablet / Smartphone motherboard enabling USB Type-C DP alternate mode.

The MCDP6000 resides next to the DisplayPort source (CPU/GPU) device, the USB 3.x host or dual-role device, and the Power Delivery (PD) controller on a same PCB with copper tracks connecting directly to these devices. High speed serial interface tracks are typical microstrip lines with controlled impedance of 100 ohm. The MCDP6000 communicates with these devices through either TWI, 3 configuration pins or AUX_CH. By default, the operating mode and the plug orientation are controlled by the PD controller or the Embedded Controller (EC) through the TWI. When the DisplayPort link is discovered by the PD controller, the link training is initiated by the DP source through the AUX_CH.

Figure 2. MCDP6000 Motherboard-Down Use Case

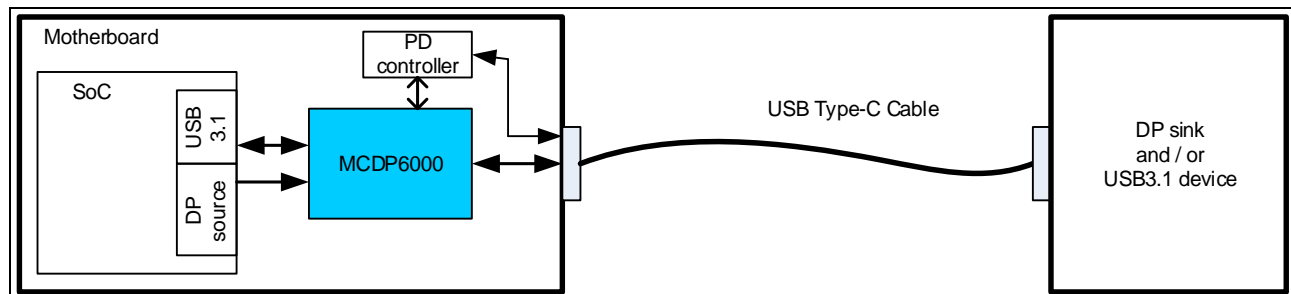

3. Functional Description

This section describes the following operations of the MCDP6000:

1. System block diagram
2. MCDP6000 block diagram
3. Receiver PHY
4. Transmitter PHY
5. DisplayPort main link receiver interface
6. AUX_CH / SBU interface
7. USB 3.2 x1 interface
8. USB Type-C connector facing interface
9. IC operation
10. Power supply
11. Power consumption
12. System interface

3.1. System Block Diagram

Figure 3. MCDP6000 System Block Diagram

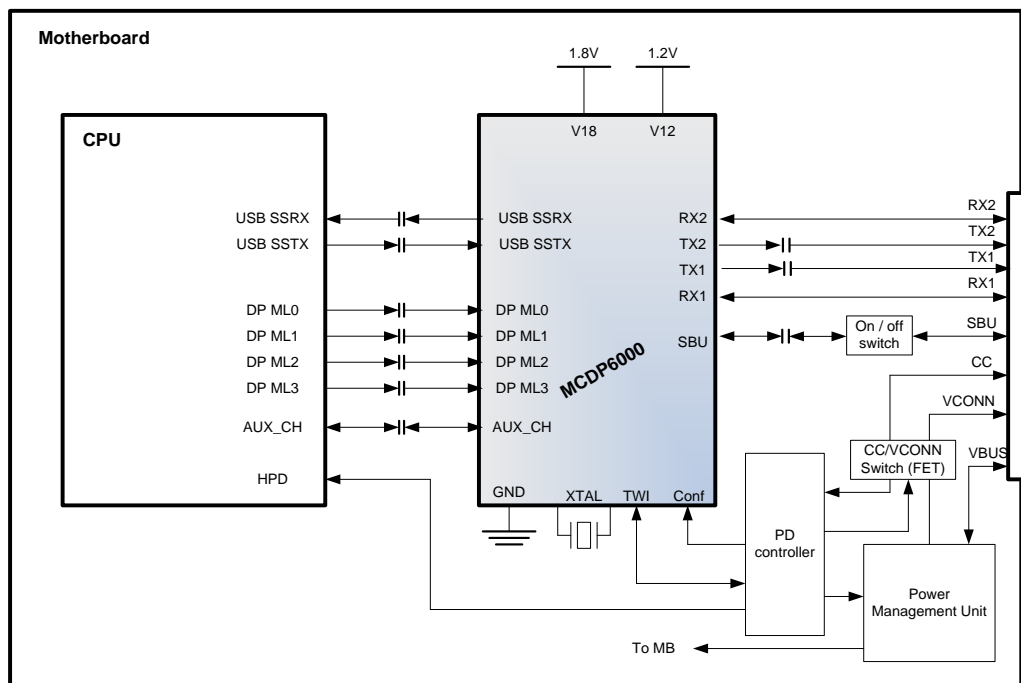

3.2. MCDP6000 Block Diagram

Figure 4. MCDP6000 Block Diagram

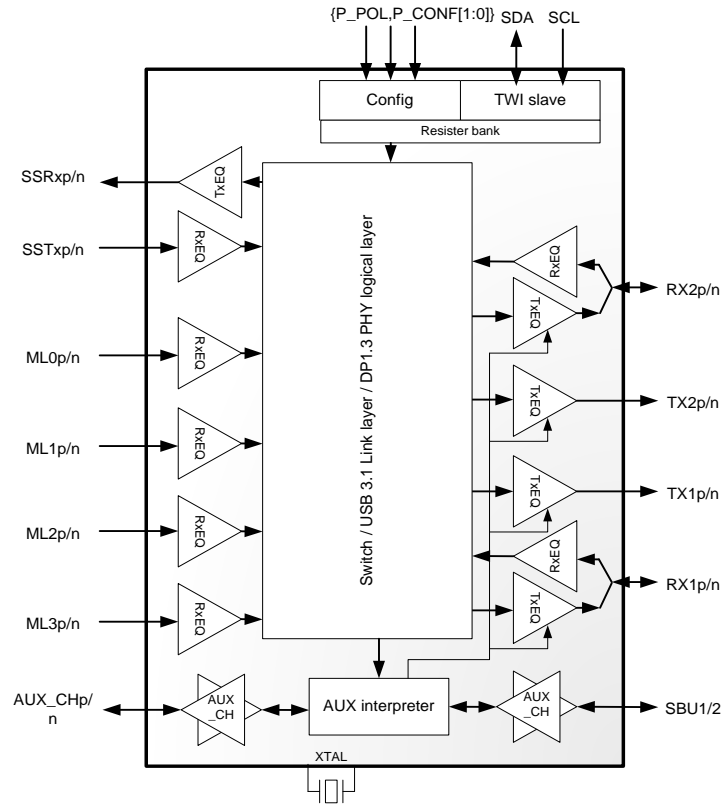

The figure above shows a block diagram of the MCDP6000. The MCDP6000 includes the following blocks.

The details of each block are described in the following sections:

1. Receiver PHY
2. Transmitter PHY
3. DisplayPort receiver interface
4. AUX_CH
5. USB 3.2 x1 (Gen1 and Gen2) interface
6. USB Type-C connector facing interface
7. TWI
8. Configuration pins
9. USB Type-C switch fabric
10. Crystal Interface for reference clock

3.3. Receiver PHY

The receiver PHY of the MCDP6000 employs CTLE and DFE with adaptive equalization logic, CDR block, a serial to parallel conversion block, and an eye opening monitor (EOM) block. The termination register of the receiver is calibrated to a differential of 100 ohm by default. Depending on the impedance of PCB track, the termination can be programmed to 80Ω.

CTLE's degeneration resistance is tunable for up to 40 steps, which corresponds to 0 dB to 16 dB peaking at 5 GHz (in a typical case). The CTLE capacitance is fixed by default.

Both the CTLE degeneration resistance and each DFE TAP value are automatically adapted to channel characteristics during the link training. By default, the adaptation time is set to a few hundred microseconds for CTLE and up to 1.5 milliseconds for DFE.

The MCDP6000 supports the real time eye opening monitor (EOM) in the background. EOM can use two different methods:

- FSM based observation of four sampling points which detects a lower BER than the configured threshold
- Scans all sampling points by software implementation

Figure 5. FSM Based Eye Scan Concept

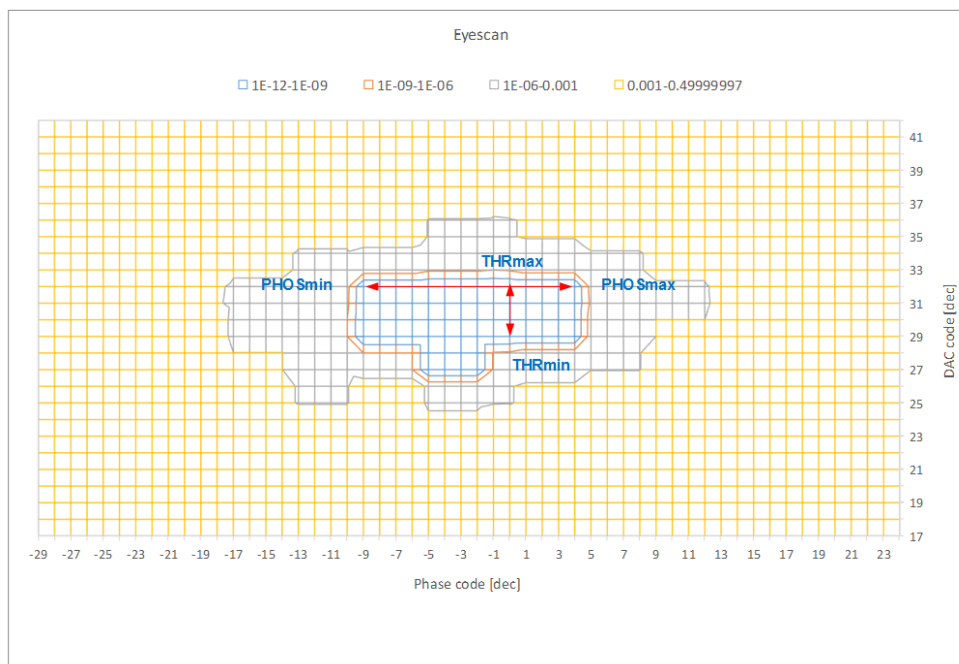

The figure above shows a concept of the FSM based EOM method. THRmax and THRmin indicate the vertical range to operate in less than 1E-9 BER. PHOSmin and PHOSmax indicate the horizontal range to operate in less than 1E-9 BER.

Scanning full range is also possible by software. The figure below is an example of a software based EOM.

Figure 6. Example Output of Software Based Eye Scan

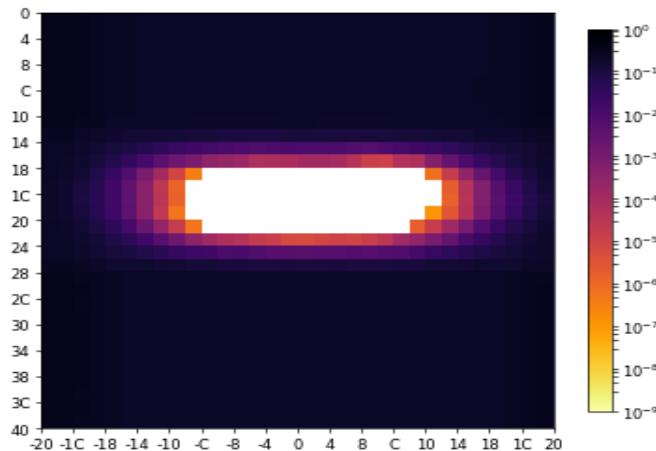

3.4. Transmitter PHY

The MCDP6000 transmitter supports up to 1000 mVpp diff swing without emphasis. The MCDP6000 supports up to 9 dB pre-emphasis. The MCDP6000 uses pre-programmed parameter sets to be compliant with USB and DP standards. The table below shows a combination of the voltage swing levels and the pre-emphasis level which the MCDP6000 supports for DP.

Table 2. DP transmitter configuration

Voltage Swing Level	Pre-emphasis Level			
	0	1	2	3
0	Support	Support	Support	Support
1	Support	Support	Support	Not Support
2	Support	Support	Not Support	Not Support
3	Support	Not Support	Not Support	Not Support

The amplitude level, pre-shoot, and the de-emphasis level for USB follow a standard requirement. As defined in the USB standard, the MCDP6000 supports a low power transmitter; the amplitude is decreased up to a 400 mVpp diff as an option.

The MCDP6000 transmitter uses the clock from a phase interpolator. The phase interpolator generates a modulated clock to support SSC (Spread Spectrum Clocking). The table below shows the origin of the SSC generator in the MCDP6000 operation modes. Since DP and USB SS operates as a BLR (Bit Level Retimer), which does not support an elasticity buffer to compensate for the clock offset, the transmitter clock has to be synchronized with the receiver clock.

Table 3. SSC source in each operation mode

Mode	SSC Source	SSC Profile
DP	From Recovered Clock	Depends on connected device
USB SS	From Recovered Clock	Depends on connected device
USB SSP	Local SSC Generator	Triangle profile

3.5. DisplayPort Receiver Interface

The MCDP6000 receives audio-video streams (DisplayPort) from a source device via the DisplayPort link (DP Link). The DP link comprises 4 main lanes and an AUX CH. The MCDP6000 does not implement an HPD interface. PD controller configures the MCDP6000 operating mode when it detects the DP alternate mode and converts the HPD state message to the HPD signal for DP source device. Both main link and AUX signals are AC-coupled at the source side.

When the MCDP6000 is configured to DP mode, the MCDP6000's AUX_CH polarity is determined by the P_POL signal set by PD controller according to the plug orientation. Once the AUX_CH polarity is properly configured, the MCDP6000 supports the link training to establish the main link as defined in the DisplayPort standard.

The MCDP6000 provides the receiver status monitor registers through the TWI. Those registers can be accessed by reading the repeater DPCD field through AUX_CH when the MCDP6000 is in non-transparent mode.

The MCDP6000 receiver includes an adaptive equalizer so that the receiving signal is properly equalized during the channel equalization phase. The adaptation is enabled when the TRAINING_PATTERN_SELECT of DPCD 'h00102 in transparent mode, or the corresponding repeater DPCD field in non-transparent mode, is TPS2, TPS3, or TPS4.

3.6. AUX_CH, SBU Interface for DisplayPort Alternate Mode

The DisplayPort Aux channel is a half-duplex bidirectional, AC-coupled, doubly-terminated differential pair. It is capable of transmitting and receiving bits at 1 Mbps. The AUX channel is used for link management and device control and handles the following functions:

1. Link training
2. Exchanging DPCD

The MCDP6000 is compliant with DPCD Rev. 1.4. The pull-down termination on AUX_CHp and the pull-up termination on AUX_CHn are used by the DisplayPort receiver device for the plug detection. Therefore a 2:2 crossbar switch is required on SBU line between the termination resistors and the USB Type-C receptacle.

Figure 7. AUX – SBU channel topology

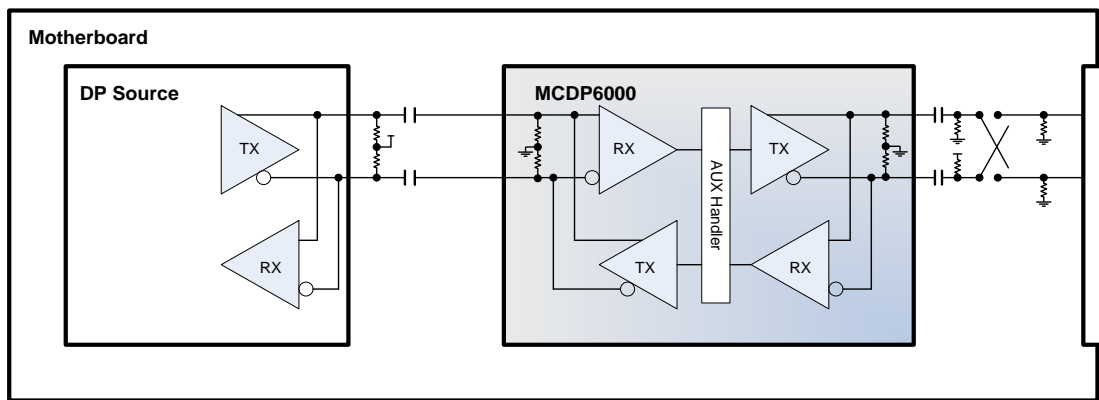

Note: The termination resistors next to the DP source may not be required when DP source integrates these resistors.

The MCDP6000 adjusts its main link transmitter amplitude level and pre-emphasis level according to the DPCD transaction of 'h00103 – 'h00106, 'h00206 and 'h00207 in the transparent mode or equivalent PHY repeater DPCD address in the non-transparent mode. The transmitter can be also configured via TWI. In addition, the MCDP6000 monitors DPCD 'h00100 – 'h00101 to decide the bit rate and the lane configuration as well as 'h00102 to enable the receiver equalizer adaptation process.

The MCDP6000's DP receiver status can be obtained through DPCD in the topology of Figure 7. The snooped information can be also read through the TWI.

3.6.1. AUX_CH latency mode

The MCDP6000 provides two AUX_CH latency modes, low latency mode and normal latency mode. The summary of the differences between two modes are described in Table 4. AUX_CH latency mode can be preconfigured by the bootstrap as described in section 3.9.1. It can be also configured through 0x350 register configuration.

Table 4. AUX_CH latency mode

mode	AUX_CH bit UI tolerance	AUX_CH propagation delay
Low latency	0.5UI -10%/+5%	15-us for round trip
Normal latency	0.5UI +/-20%	100-us for round trip

Table 5. 0x350 register definition

0x350	DP_RT_CONFIG		RW
POD: 0x0000000F			
BIT	BIT NAME	FUNCTION	
3:0	DP_RXEQ_CONT	DP Rx EQ adaptation option for [0] RBR, [1] HBR, [2] HBR2, [3] HBR3 0: Rx EQ adaptation during TPS2-4 (Default) 1: Rx EQ adaptation during TPS2-4 and the beginning of Video stream	
4	RTMR_DP_AUX_CONFIG	0: Low latency mode (Default) 1: Normal latency mode	
6:5	Reserved	Reserved	
7	DPRX_RST_CONFIG	0: initialize DPRX upon DPCD 100h and 600h write acknowledgement (Default) 1: disable DPRX initialization based on DPCD 100h and 600h	
8	Reserved	Reserved	
9	RETIMER_CONFIG_RW9	Bootstrap override enable for RTMR_DP_AUX_CONFIG[0]	
31:10	Reserved	Reserved	

When the MCDP6000 is embedded in DPRX system operating in the transparent mode of LTTPr, the AUX_CH propagation delay needs to be as part of the AUX_CH response time from the DPRX device. (e.g. in normal latency mode, 50-us is already added when the DPRX device received the AUX_CH request from DPTX and another 50- μ s is added when the DPTX detects DPRX response. Therefore AUX_CH response

should be prepared within 200- μ s by DPRX. Otherwise, DPRX should respond with AUX_DEFER by 200- μ s timer timeout.)

When the MCDP6000 is embedded in DPTX system operating in the transparent mode of LTTPR, it is recommended to configure the MCDP6000 to the normal latency mode and configure the AUX_CH response timeout timer to 500- μ s instead of 400- μ s.

When the MCDP6000 is cascaded in the active cable, it is recommended to configure the MCDP6000 at the DPRX side to the normal latency mode and the other to the low latency mode.

3.7. USB 3.2 x1 Interface

The MCDP6000 receives and transmits USB 3.2 x1 Gen1 and Gen2 bit rate stream. The USB link comprises a receiver lane and a transmitter lane.

The MCDP6000 USB 3.2 x1 receiver includes an adaptive equalizer so that the receiving signal is properly equalized during the channel equalization phase. The adaptation is enabled when the RTSSM (Retimer Training and Status State Machine) enters the Polling.RxEQ state. The MCDP6000 configures the pre-emphasis setting according to whether it is SS bit rate or SSP bit rate.

3.8. USB Type-C Connector Facing Interface

The MCDP6000 USB Type-C connector facing interface (Type-C IF) consists of two lanes of bi-directional high-speed interface, two lanes of a high-speed transmitter and a Side Band Use (SBU) bi-directional interface, which is mainly for AUX (auxiliary channel) communication in the DP alternate mode.

The MCDP6000 Type-C receiver implementation is the same as the one in the USB 3.2 x1 interface except for the multiplexing capability with the transmitter.

The MCDP6000 Type-C transmitter implementation uses the same building block as a USB 3.2 x1 interface. The Type-C transmitter supports a DP transmitter in addition to the USB 3.2 x1 transmitter. While the USB 3.2 x1 transmitter uses fixed parameters, the DP transmitter changes its transmitter parameters according to the adjustment request from a sink device during the link training.

3.9. IC Operation

3.9.1. Bootstrap

Table 6. MCDP6000 Bootstrap operation

Bootstrap	P_CONF0	P_CONF1	Description
00	0	0	MCDP6000 enters low power mode upon the power-up.
01	1	0	MCDP6000 enters USB 3.2 x1-only mode upon the power-up.
11	1	1	MCDP6000 enters USB 3.2 x1 + DP 2L mode upon the power-up

Table 7. MCDP6000 Bootstrap for AUX_CH latency mode

TWISLV1	Description
0	Low latency mode
1	Normal latency mode

When the bootstrap is 00 or 11, the external pin control is enabled. To change the control mode to TWI control mode, the following bits should be set to 1:

- OPMODE_CONF.PPOL_BS_OVR
- OPMODE_CONF.PCONF0_BS_OVR
- OPMODE_CONF.PCONF1_BS_OVR

Table 8. Operation mode configuration register

0x504		OPMODE_CONF	RW
Chip configuration			
BIT	BIT NAME	FUNCTION	
0	Reserved		
1	PPOL_OVR_EN	P_POL_OVR_EN, 0: GPIO setting, 1: I ² C setting	
2	PCONF0_OVR_EN	P_CONF0_OVR_EN, 0: GPIO setting, 1: I ² C setting	
3	PCONF1_OVR_EN	P_CONF1_OVR_EN, 0: GPIO setting, 1: I ² C setting	
4	PPOL	P_POL	
5	PCONF0	P_CONF0	
6	PCONF1	P_CONF1	
7	Reserved		
8	IC_SOFT_RST	0: Normal operation 1: Reset IC except for registers	
9	USB_SOFT_RST	0: Normal operation 1: Reset USB data path	
10	DP_SOFT_RST	0: Normal operation 1: Reset DP data path	
11	DP_AUX_SOFT_RST	0: Normal operation 1: Reset DP data path	
12	PPOL_BS_OVR	Bootstrap override enable for P_POL	
13	PCONF0_BS_OVR	Bootstrap override enable for P_CONF0	
14	PCONF1_BS_OVR	Bootstrap override enable for P_CONF1	
15	Reserved		
16	DP_LT_AMP_PRE_CHK_DIS	0: Enable EQ adaptation result check to request different voltage swing or pre-emphasis level 1: Disable EQ adaptation result check during DP link training	
17	DP_LT_SYMB_ERR_CHK_DIS	0: Enable symbol error count check to request different voltage swing or pre-emphasis level 1: Disable symbol error count check during DP link training	
31:18	Reserved	Reserved	

3.9.2. IC Top-Level State Machine

The figure below shows the state machine to control the MCDP6000. This state machine changes the MCDP6000 operation mode based on the configuration registers or pins. The MCDP6000 provides two options to trigger the state change as explained in Section 3.9.3 and Section 3.9.4.

Figure 8. MCDP6000 Operation Mode State Machine

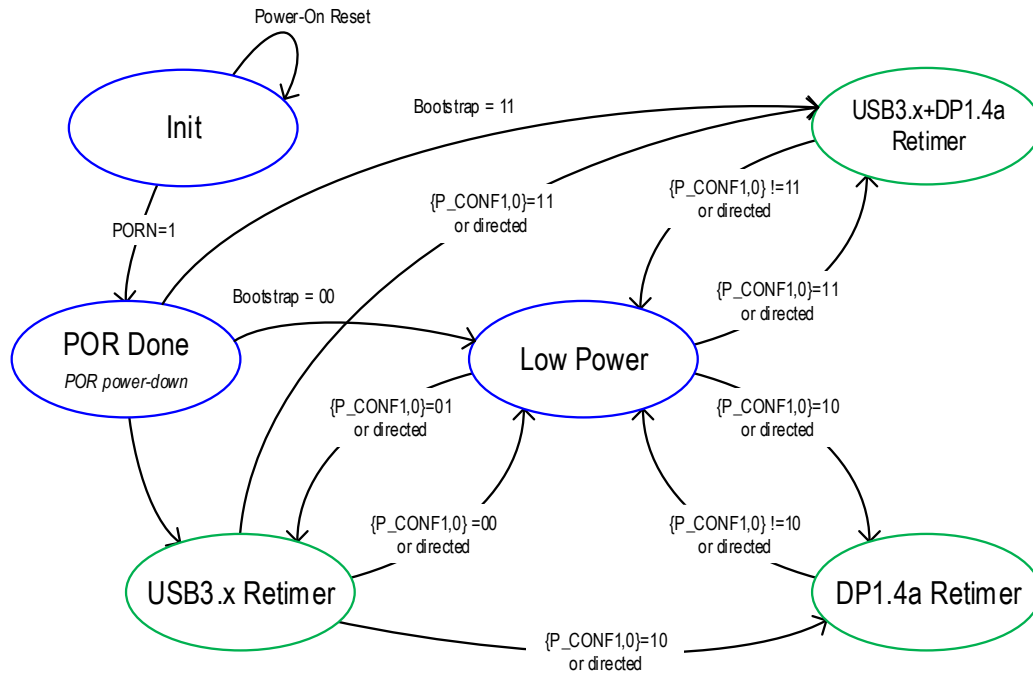

Table 9. MCDP6000 Operating Mode

P_POL	{P_CONF1, P_CONF0}	Description
Don't care	{0,0}	Low power mode. (All blocks are powered down except configuration pins and TWI slave.)
0	{0,1}	USB only (normal orientation)
1	{0,1}	USB only (flipped orientation)
0	{1,0}	DisplayPort 4 lane; pin assignment C (normal orientation)
1	{1,0}	DisplayPort 4 lane; pin assignment C (flipped orientation)
0	{1,1}	USB + DisplayPort 2 lane; pin assignment D (normal orientation)
1	{1,1}	USB + DisplayPort 2 lane; pin assignment D (flipped orientation)

3.9.3. TWI Programmable Mode

The MCDP6000 operation mode should be controlled through the TWI programming interface in default. The default state after the power-on is the USB 3.2 x1 Only mode. The MCDP6000 changes its state according to the directives from the policy engine through TWI.

3.9.4. Stand-Alone Mode

The MCDP6000 also provides the three configuration pins for its operation mode. By enabling this feature through TWI, P_POL and P_CONF0/1 pins can be used to determine the operating mode. These pins provide the controllability for the USB Type-C plug orientation and the pin assignment to users. The function of P_POL and P_CONF0/1 is shown in the table below.

Note: P_POL, P_CONF0 and P_CONF1 I/Os are designed to operate under 1.8 V in nominal case. Connecting these I/O with 3.3 V output buffer would cause damage.

Note: MCDP6000 must be connected to a controller through TWI for IC configuration. The exceptional use case must be reviewed.

3.9.5. Low Power Mode

The MCDP6000 enters into the low power mode when P_CONF0/1 is set to 2'b00. Upon the power-up, P_CONF should be 2'b00 for the lowest power consumption. Only P_CONF, P_POL, the TWI slave and the register banks in always power-on domain are enabled in the low power mode. The MCDP6000 can be programmed through the TWI for any required changes in the configuration of low power mode. When the operating mode changes from other states to the low power mode, the MCDP6000 goes through the reset cycle except for the register bank in always power-on domain.

The far-end termination detection of USB 3.2 x1 is not performed in the low power mode. In addition, the receiver termination is not present; for example, the high impedance is present on the transmitter channel, so that the USB link partner recognizes the missing USB link connection.

3.9.6. USB 3.2 x1 Retimer Operation

The MCDP6000 enters USB 3.2 x1-only mode during power-on-reset. Otherwise, the MCDP6000 enables the USB 3.2 x1 retimer when P_CONF0 is set to 1'b1.

The MCDP6000 starts far-end termination detection upon the activation of the USB 3.2 x1 retimer until the receiver termination on the link partner is detected. Unless the MCDP6000 is directed to transit to the low power state via P_CONF pins or detects the far-end receiver termination, the MCDP6000 stays in the RX.detect state as described in the USB 3.2 x1 standard.

The MCDP6000 operates as BLR (Bit-Level Retimer) in SS mode and as SRIS (Separate Reference Clock Independent SSC) in SSP mode.

Note for PHY Capability LBPM handling

The MCDP6000 does not reset b4-b6 in PHY Capability LBPM while the received LBPMs are forwarded. If the connected UFP device and DFP device are USB 3.2 x2 capable, LBPM handshake between the UFP device and the DFP device will be established while the MCDP6000 stays Polling.SpeedDetect state. The LTSSM in the UFP device and the DFP device will detect the tPollingActiveTimeout in Polling.Active state, then both devices will restart the next link training with Gen2 x 1 configuration.

BLR for SS mode

The BLR minimizes the propagation delay of the retimer data path while it still snoops the link commands and a few other LMP (Link Management Packet) to participate in the link configuration process and the link power management.

During the link training, the BLR transmitter may or may not enable SSC. The transmitter clock is synchronized with the recovered clock in the Polling.TSx state.

The transmitter clock is synchronized with the recovered clock through a low pass filter of the phase code. As this filter's cut-off frequency is lower, the frequency to show the jitter transfer becomes lower. The filter bandwidth is pre-programmed at 1 MHz.

SRIS for SSP mode

The SRIS transmits the data with its own reference clock independent of the recovered clock. Therefore, the transmitter data does not include the jitter from the receiver side. The elasticity buffer compensates the clock offset between the receiver and the transmitter by removing or adding SKP symbols.

The MCDP6000 also supports the synchronization of the transmitter clock with the recovered clock. In this mode, the low frequency jitter is transferred, but the SKP symbol removal or addition rarely occurs since the clock offset is not expected.

3.9.7. DisplayPort Retimer Operation

The MCDP6000 operates as the DisplayPort 2 lane or 4 lane LT-tunable PHY repeater at the DisplayPort bit rate of RBR, HBR, HBR2 and HBR3 when the P_CONF1 is set to 1'b1. The default is transparent mode as defined in DisplayPort1.4a standard. The MCDP6000 can be set to non-transparent mode by writing AAh to F0003h of the DPCD address. Non-transparent mode is allowed only when the DPCD revision is DPCD Rev. 1.4 or higher.

The HPD signal is not routed to the MCDP6000. The MCDP6000 transitions to the DP sink detected state when P_CONF1 is set to 1'b1. The MCDP6000 supports DPCD version 1.4.

The MCDP6000 supports transparent mode and non-transparent mode.

Transparent Mode

The transparent mode is the default operating mode of the MCDP6000 when the DisplayPort alternate mode is enabled and the MCDP6000 is used in the topology shown in Figure 7.

The MCDP6000 starts charging the AC coupling capacitors on the transmission lines of the main links and AUX_CH as soon as P_CONF1 is set to 1'b1.

The MCDP6000 snoops some link configuration registers the same way as in snooping mode. However, the MCDP6000 manipulates the received ADJUST_REQUEST_LANE_x message from the sink device according to its receiver link training status. When the MCDP6000 receiver is trained while the sink device receiver is still not trained, the MCDP6000 manipulates the received ADJUST_REQUEST_LANE_x message so that the source device does not change the transmitter parameter. When the receiver of the MCDP6000 is not trained when it receives the adjusted request, the MCDP6000 manipulates the received ADJUST_REQUEST_LANE_x based on its preprogrammed adjust request sequence.

The MCDP6000 manipulates TRAINING_LANE_x_SET from the source device to be consistent with its manipulation of ADJUST_REQUEST_LANE_x.

The MCDP6000 changes its transmitter configuration based on the ADJUST_REQUEST_LANE_x field, which determines the DPTX' voltage swing level and pre-emphasis magnitude.

Non-Transparent Mode

The MCDP6000 operates as defined in the section of the LT-tunable PHY repeater of DisplayPort1.4a.

3.10. Power Supply

The MCDP6000 supports 1.8V and 1.2V supplies.

Note: There is no relationship between 1.8 V ramp-up timing and 1.2 V ramp-up timing. 1.2 V can be supplied earlier than 1.8 V. Each power supply ramp-up time shall be between 200- μ s and 10-ms.

3.11. Power Consumption

Table 10. Power Consumption (Preliminary estimation in typical conditions)

IC Operation Mode	State	Power Consumption (mW)
Low Power Mode	Low Power Mode	0.85
USB 3.2 x1 Only	RX.detect	0.85
USB 3.2 x1 Only	U0	290
USB 3.2 x1 Only	U1	160
USB 3.2 x1 Only	U2 (default)	3.2
	U2 (lower power U2 mode)	0.85
USB 3.2 x1 Only	U3	0.85
DisplayPort 4 lane DP_BR (HBR3)	D0 power state	460
DisplayPort 4 lane DP_BR (HBR3)	D3 power state	10
USB + DisplayPort 2 lane HBR3	Combination of USB 3.2 x1 state and DisplayPort 2 lane HBR3	520

3.12. System Interface

3.12.1. TWI

The TWI slave is intended for an external host controller to configure the MCDP6000 registers for certain use cases. TWI is accessible in any operating mode. The TWI is compatible with I²C master device.

Note: SDA and SCL shall be pulled up to 3.3 V.

TWISLV0 and TWISLV1 are designed to operate under 1.8V in nominal case. Connecting these I/O with a 3.3 V output buffer would cause damage.

TWI Device ID

The TWI of the MCDP6000 operates as the slave. Four device IDs can be supported. Each device’s ID is determined by the TWISLV0 and TWISLV1 pins as shown in the table below. The TWISLV0/1 pull-up/down status is detected by the MCDP6000 during the power-up sequence.

Table 11. TWI Device ID Configuration

TWISLV1	TWISLV0	Slave ID
Pulled down to Ground	Pulled down to Ground	0x14
Pulled down to Ground	Pulled up to 1.8V	0x15
Pulled up to 1.8V	Pulled down to Ground	0x16
Pulled up to 1.8V	Pulled up to 1.8V	0x17

TWI Read / Write Access

The TWI access to the MCDP6000 is 32-bit write or read. All register accesses are on 32-bit word boundaries. Address auto-increment is also allowed on 32-bit word boundary. Stop / Repeated start can be used to change the base address to a new address definition.

The figure below shows typical write access:

1. Master sends Slave ID with write access.
2. Master sends lower byte of 16-bit register address.
3. Master sends higher bytes of 16-bit register address.

- Master sends data bytes to be written in order of lower byte to higher byte.

Figure 9. Write Access

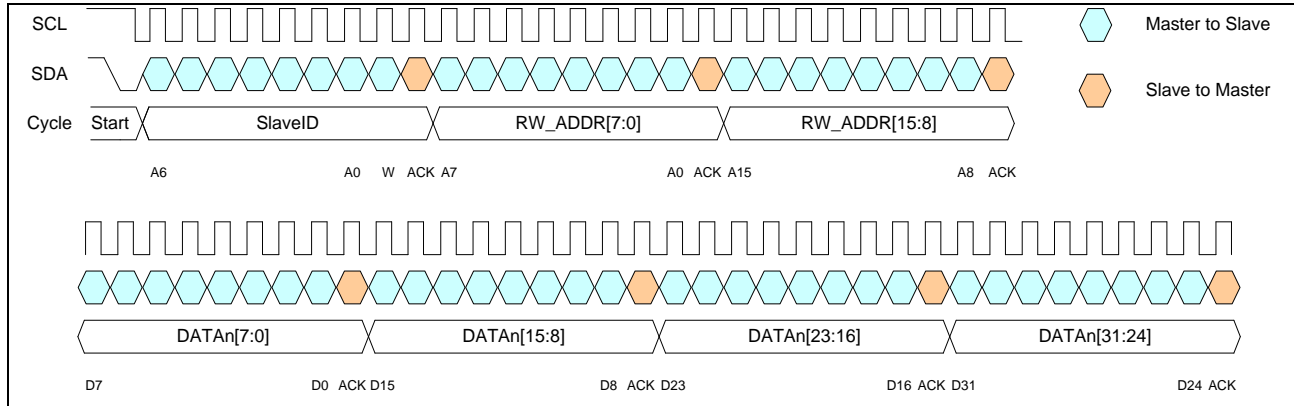

The figure below shows typical read access:

- Master sends Slave ID with write access.
- Master sends lower byte of 16-bit register address.
- Master sends higher bytes of 16-bit register address.
- Master sends re-start with read access.
- Slave responds with data bytes.

Figure 10. Read Access

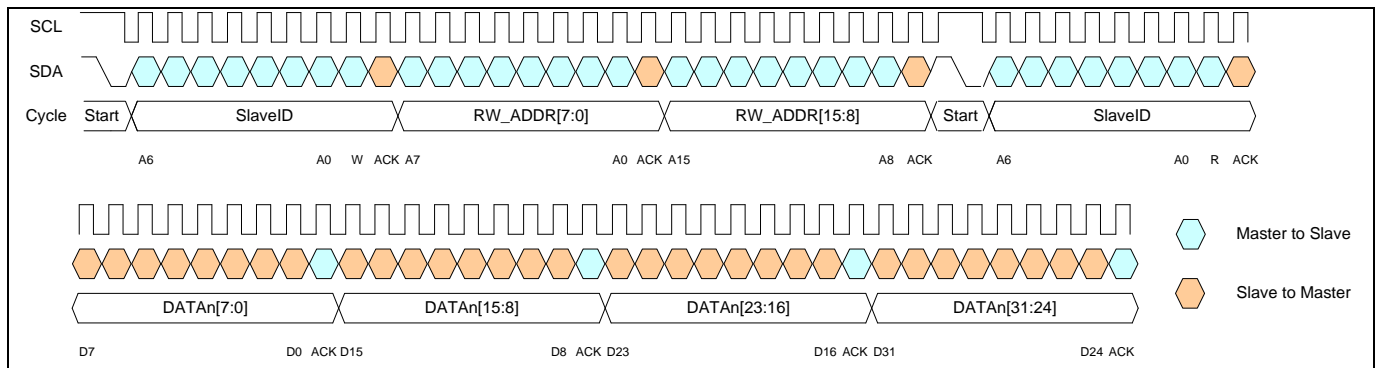

3.12.2. XTAL Buffer Operation

When a crystal resonator is connected between the XIN pin and XOUT pin with the appropriate-sized loading capacitors C1 and C2, the internal oscillator becomes active. A 25 MHz crystal oscillation is required to meet the frequency requirements from the USB and DisplayPort.

Note: The size of C1 and C2 is determined from the crystal manufacturer's specification and by compensating for the parasitic capacitance of the device and the printed circuit board traces. The loading capacitors are terminated to the ground.

Figure 11. Internal Oscillator with an External Crystal

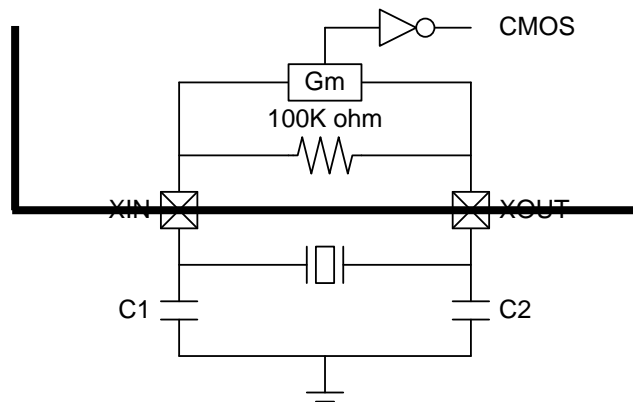

Recommendation for the crystal is shown in the table below.

Table 12. Recommended Crystal Specifications

Parameters	Specifications
Frequency	25.000 MHz
Operation mode	Fundamental
Operating temperature	-10°C to +70°C
Frequency tolerance @25C	+/- 50 ppm max
Equivalent series resistance	< 50Ω

Suggested load capacitance value is 10pF ~ 12pF.

3.12.3. Reference Clock Input

The MCDP6000 can also use the reference clock input. XIN can be the reference clock input buffer. When the reference clock is used, XOUT has to be floated. Setting bit 30 of RETIMER_CONFIG3 register (address 0x30C) enables the single-ended reference clock input buffer.

Table 13. Recommended Reference Clock Input Characteristics

Parameters	Specifications
Frequency	25.000 MHz
Frequency tolerance @25°C	+/- 50 ppm max
Maximum Input Voltage	1.8 V

3.12.4. Reference Clock Output

The MCDP6000 supports cascading the reference clock for the system which implements multiple USB Type-C ports closely. The reference clock output can be enabled or disabled through the TWI register when other USB Type-C ports do not require the reference clock. The MCDP6000 does not require the reference clock in low-power mode, Rx.Detect, U2 and U3 state in USB 3.2 x1 Only mode. The MCDP6000 requires the reference clock when DisplayPort channels are active or the USB 3.2 x1 is in another state other than the Rx.Detect, U2 and U3 states.

Table 14. Reference Clock Output Characteristics

Parameters	Specifications
Frequency	25.000 MHz
Frequency tolerance @25C	+/- 50 ppm max
Maximum output Voltage	0.9 V
Load capacitance	< 5 pF

Figure 12. Cascading Reference Clock Across Multiple MCDP6000

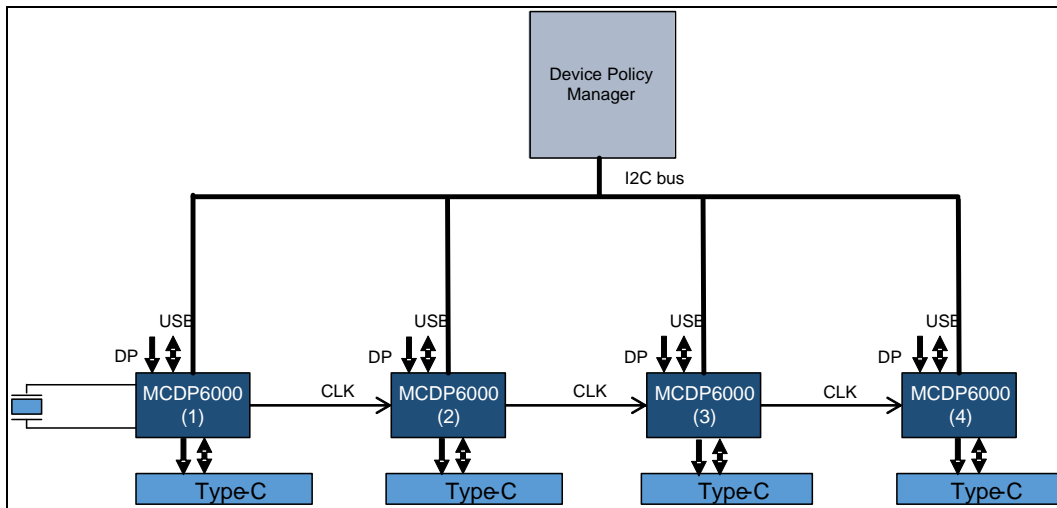

Note: To enable the reference clock cascading, MCDP6000 should be configured sequentially from MCDP6000 (1) in Figure 12, followed by MCDP6000 (2).

Bit 30 and 31 shall be programmed to cascade the reference clock. Bit 30 is to use the single-end reference clock instead of XTAL. Bit 31 is to output the single-end clock. Until the reference clock is available, the MCDP6000 operates with internal ring oscillator.

Table 15. Reference Clock Configuration Register Definition

0x30C	IC_RT_CONFIG		RW
POD: 0x005FFC03			
BIT	BIT NAME	FUNCTION	
15:0	Reserved	Reserved	
16	USB_G2_MODE_SEL	USB Gen2 operation mode selection 0: Proprietary operation mode 1: Spec compliant operation mode	
19:17	Reserved	Reserved	
20	FAST_U2_EXIT_EN	0: 1msec exit time for Phy, but the U2 power is less than 1mW 1: 300usec exit time for Phy, but the U2 power is about a few mW (default)	
29:21	Reserved	Reserved	
30	XTAL_REF_MODE	0: Normal operation (crystal driven mode) (Default) 1: Single-end reference clock receiver mode	
31	REFOUT_EN	REFOUT enable. Active high. 0: Disable REFOUT (Default) 1: Enable REFOUT	

4. Pin Description

Figure 13. MCDP6000 Ex-VQFN46 Pin Assignment (Top-View)

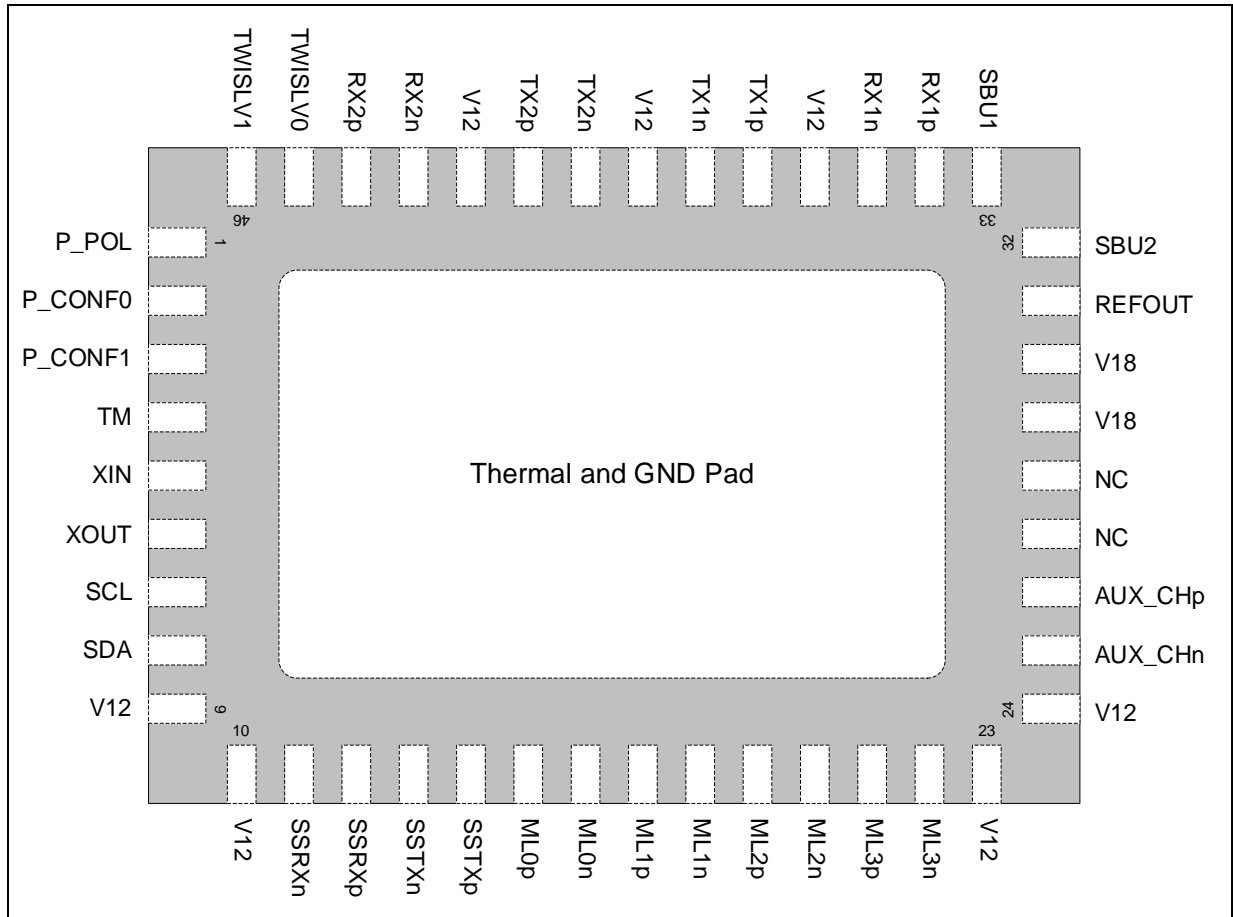

I/O Legend:

I = Input; O = Output; P = Power, G = Ground; IO = Bi-direction

Table 16. Pin Description

Ex-VQFN46	Name	I/O	Description
1	P_POL	I	USB Type-C plug orientation configuration pin Low: normal orientation High: flipped orientation
2	P_CONF0	I	Bit 0 of operating mode configuration pin
3	P_CONF1	I	Bit 1 of operating mode configuration pin
4	TM	I	Test Mode pin. Internally pulled-down to GND.
5	XIN		XTAL nodes. XIN: When the oscillator clock is used as reference, connect to the clock
6	XOUT		XOUT: When the oscillator clock is used as reference, float this pin.
7	SCL	I	I ² C clock line. External pull-up required for I ² C operation. Leave NC when not used.
8	SDA	IO	I ² C data line. External pull-up required for I ² C operation. Leave NC when not used.
9	V12	P	1.2 V power supply.
10	V12	P	1.2 V power supply.
11	SSRXn	O	USB SSRX negative analog output. Should be connected with the CPU SSRXn pin.
12	SSRXp	O	USB SSRX positive analog output. Should be connected with CPU's SSRXp pin.
13	SSTXn	I	USB SSTX negative analog input. Should be connected with CPU's SSTXn pin.
14	SSTXp	I	USB SSTX positive analog input. Should be connected with CPU's SSTXp pin.
15	ML0p	I	DisplayPort receiver main link Lane 0 positive analog input

Ex-VQFN46	Name	I/O	Description
16	ML0n	I	DisplayPort receiver main link Lane 0 negative analog input
17	ML1p	I	DisplayPort receiver main link Lane 1 positive analog input
18	ML1n	I	DisplayPort receiver main link Lane 1 negative analog input
19	ML2p	I	DisplayPort receiver main link Lane 2 positive analog input
20	ML2n	I	DisplayPort receiver main link Lane 2 negative analog input
21	ML3p	I	DisplayPort receiver main link Lane 3 positive analog input
22	ML3n	I	DisplayPort receiver main link Lane 3 negative analog input
23	V12	P	1.2 V power supply.
24	V12	P	1.2 V power supply.
25	AUX_CHn	IO	DisplayPort receiver auxiliary channel negative analog input/output.
26	AUX_CHp	IO	DisplayPort receiver auxiliary channel positive analog input/output.
27	NC	-	Not Connected
28	NC	-	Not Connected
29	V18	P	1.8 V power supply
30	V18	P	1.8 V power supply
31	REFOUT	O	Reference clock output
32	SBU2	IO	Side Band Use signal of USB Type-C. Mainly for DP AUX_CH.
33	SBU1	IO	Side Band Use signal of USB Type-C. Mainly for DP AUX_CH.
34	Rx1p	IO	USB Type-C Rx1 positive analog input in USB mode. DP ML3 or ML0 transmitter positive analog output in DP mode.
35	Rx1n	IO	USB Type-C Rx1 negative analog input in USB mode. DP ML3 or ML0 transmitter negative analog output in DP mode.

Ex-VQFN46	Name	I/O	Description
36	V12	P	1.2 V power supply.
37	Tx1p	O	USB Type-C Tx1 positive analog output in USB mode. DP ML2 or ML1 transmitter positive analog output in DP mode.
38	Tx1n	O	USB Type-C Tx1 negative analog output in USB mode. DP ML2 or ML1 transmitter negative analog output in DP mode.
39	V12	P	1.2 V power supply.
40	TX2n	O	USB Type-C TX2 negative analog output in USB mode. DP ML1 or ML2 transmitter negative analog output in DP mode.
41	TX2p	O	USB Type-C TX2 positive analog output in USB mode. DP ML1 or ML2 transmitter positive analog output in DP mode.
42	V12	P	1.2 V power supply.
43	RX2n	IO	USB Type-C RX2 negative analog input in USB mode. DP ML0 or ML3 transmitter negative analog output in DP mode.
44	RX2p	IO	USB Type-C RX2 positive analog input in USB mode. DP ML0 or ML3 transmitter positive analog output in DP mode.
45	TWISLV0	I	Bit 0 of TWI device ID. Internally pulled-down to GND.
46	TWISLV1	I	Bit 1 of TWI device ID. Internally pulled-down to GND.
TGP	GND	G	Thermal and GND Pad. Connect to Ground for electrical and thermal usage.

5. Package Specification

Package type:

Ex-VQFN46 (6.5 x 4.5, 46 pins, 0.40 mm pitch)

5.1. Package Drawing and Dimensions

Figure 14. MCDP6000 Ex-VQFN46 Package Outline Drawing (unit: mm)

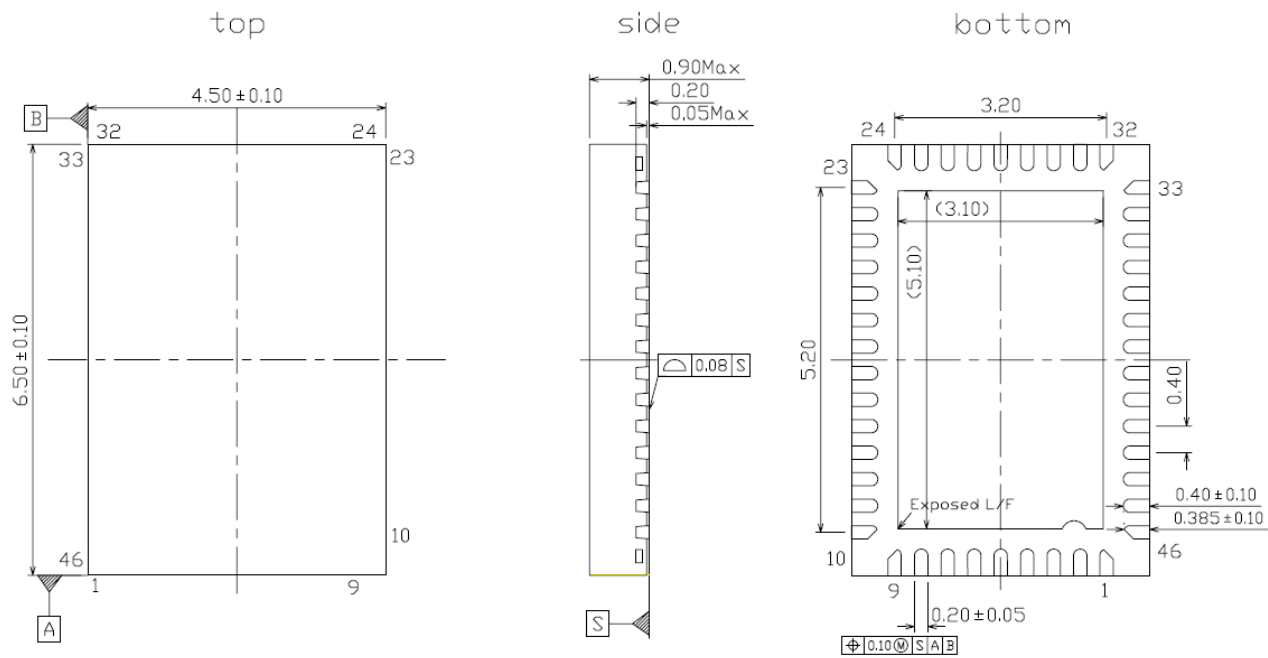

6. Marking Field Template and Descriptors

Figure 15. MCDP6000 Ex-VQFN46 Marking Template



Table 17. Field Descriptors

Field	Description	Marking
DOT	Pin1 indicator	DOT
Line 1	Company logo	KT LOGO
Line 2	Part Number + IC revision	MCDP6000RR
Line 3	TNNNNN: Fab Lot Number	"Variant"
Line 4	YYWW: Assembly Date Code (Work Year & Work Week) V: Assembly Vendor Code XXX: Serial Number	"Variant"

7. Electrical Specifications

7.1. Absolute Maximum Ratings

Table 18. Absolute Maximum Ratings¹
 $(T_A = 25^{\circ}\text{C}$ unless otherwise stated)

Symbol	Description	Value	Units
V _{DD_1.8V}	VDD1.8V to GND	-0.3 to 2.5	V
V _{DD_1.2V}	VDD1.2V to GND	-0.3 to 1.5	V
V _{RF_IN}	USB, SSTX, DP, MIn, RX1, RX2 to GND	-0.3 to 1.4	V
V _{RF_OUT}	USB, SSRX, TX1, TX2 to GND	-0.3 to 1.4	V
T _J	Junction Operating Temperature Range	-0 to 125	°C
T _S	Storage Temperature Range	-55 to 150	°C
T _{LEAD}	Maximum Soldering Temperature (at leads, 10 sec)	260	°C

7.2. ESD and Latch-up ratings

Table 19. ESD and Latch-up Ratings²

Symbol	Description	Value	Units
V _{ESD_HBM}	JEDEC JESD22-A114 ESD HBM (all pins)	±2.0	kV
V _{ESD_CDM}	JEDEC JESD22-C101 ESD CDM (all pins)	±500	V
I _{LU}	JEDEC JESD78	±100	mA

7.3. Thermal Capabilities

Table 20. Thermal Capabilities³

Symbol	Description	Value	Units
Θ _{JA}	Thermal Resistance – Junction to Ambient	36.6	°C/W
Θ _{JC}	Thermal Resistance – Junction to Case	19.5	°C/W
φ _{JT}	Thermal Resistance – Junction to Package Top	0.3	°C/W
φ _{JB}	Thermal Resistance – Junction to PCB	10.3	°C/W

1. Stresses above those listed in Absolute Maximum Ratings may cause permanent damage to the device. Functional operation at conditions other than the operating conditions specified is not implied. Only one Absolute Maximum rating should be applied at any one time.

2. ESD and Latch-up Ratings conform to JEDEC industry standards. Some pins may actually have higher performance. Ratings apply with chip enabled, disabled, or unpowered, unless otherwise noted.

3. Junction to Ambient thermal resistance is highly dependent on PCB layout. Values are based on thermal properties of the device when soldered to a four-layer JEDEC PCB board, no heat spreader, and no air flow.

7.4. Recommended Operating Conditions

Table 21. Recommended Operating Conditions

Description	Range
1.2V Supply Voltage	1.14V to 1.26V
1.8V Supply Voltage	1.65V to 1.95V
Ambient Operating Temperature Range	0°C to 70°C
Junction Operating Temperature Range	0°C to 125°C

7.5. Electrical Characteristics

7.5.1. DC characteristics

Table 22. DC Characteristics

Specifications	Symbol	Unit	Min	Typ	Max	Comments
Supply Current in 4-Lane active mode (USB 3.2 x1 Gen2 + DisplayPort HBR3 2 lane)						
VDD 1.8 V	I _{d18}	mA		10	13	
VDD 1.2 V	I _{d12}	mA		420	605	
Supply Current in low power mode ({P_CONF1,P_CONF0}={0,0})						
VDD 1.8 V	I _{s18}	μA		70		
VDD 1.2 V	I _{s12}	μA		600		
Open drain IO (SCL, SDA)						
Input voltage	V _{pad}	V	3	3.3	3.6	
Input high voltage	V _{ihod}	V	2.4			
Input low voltage	V _{ilod}	V			0.35	
Output low Current	I _{ol}	mA	5.3	8.7	10.7	At Vol = 0.4V
Schmitt trigger pins (TWISLV0/1)						
Positive Going Threshold Voltage	V _{t+}	V	0.4 V ₁₈		0.7 V ₁₈	V _{OUT} >= V _{OH(min)}
Negative Going Threshold Voltage	V _{t-}	V	0.3 V ₁₈		0.6 V ₁₈	V _{OUT} <= V _{OL(max)}
Hysteresis Voltage	V _h	V	0.1 V ₁₈		0.5 V ₁₈	V _{t+} - V _{t-}
Input low current	I _{ILst}	uA			10	
Input high current	I _{IHst}	uA			10	

P_CONF0/1, P_POL						
Input low voltage	V _{IL}	V	-0.3		0.3 V ₁₈	
Input high voltage	V _{IH}	V	0.65 V ₁₈		V ₁₈ +0.3	
Input low current	I _{IL}	uA			10	
Input high current	I _{IH}	uA			10	

7.5.2. DisplayPort transmitter

AC characteristics parameters are guaranteed by the silicon characterization across operating condition unless otherwise specified. Not all parameters are tested in the production test.

Table 23. DisplayPort transmitter characteristics

Parameter	Symbol	Unit	Min	Typ	Max	Comments
DisplayPort Main-Link transmitter system parameters (Type-C interface in DP mode)						
Differential output voltage range	V _{TX_DIF_PP_RANGE}	V			1.05	
Termination control range	R _{TX_TERM_RANGE}	ohm	80		120	
Frequency for high bit rate 3	f _{HBR3}	Gbps		8.1		
Frequency for high bit rate 2	f _{HBR2}	Gbps		5.4		
Frequency for high bit rate	f _{HBR}	Gbps		2.7		
Frequency for reduced bit rate	f _{RBR}	Gbps		1.62		
Link clock down-spreading amplitude	SSC _{DPTX_AMP}	%	0		0.5	
Link clock down-spreading frequency	SSC _{DPTX_FREQ}	kHz	30		33	
AC coupling capacitor	C _{TX_DP}	nF	75		265	
HBR3/HBR2 transmitter TP2 parameters						
Ratio of Voltage Swing (VSL[1]/VSL[0])	R _{VSL_1_0_HBR3_2}	dB	1.6		4.5	Calculated using measured value of 1 st harmonic of FFT at TX_EOL[0]
Ratio of Voltage Swing (VSL[2]/VSL[0])	R _{VSL_2_0_HBR3_2}	dB	3.2		7.0	
Ratio of Voltage Swing (VSL[3]/VSL[0])	R _{VSL_3_0_HBR3_2}	dB	4.8		10.5	
Ratio of Voltage Swing (VSL[2]/VSL[1])	R _{VSL_2_1_HBR3_2}	dB	1.1			
Ratio of Voltage Swing (VSL[3]/VSL[2])	R _{VSL_3_2_HBR3_2}	dB	1.1			

Parameter	Symbol	Unit	Min	Typ	Max	Comments
Delta of TX Pre-emphasis TX_EQL[1]/TX_EQL[0]	$\Delta_{EQL_1_0_HBR3_2}$	dB	1.3		4.0	Calculated using measured value of 1 st and 5 th harmonics of FFT
Delta of TX Pre-emphasis TX_EQL[2]/TX_EQL[0]	$\Delta_{EQL_2_0_HBR3_2}$	dB	2.4		6.0	
Delta of TX Pre-emphasis TX_EQL[3]/TX_EQL[0]	$\Delta_{EQL_3_0_HBR3_2}$	dB	3.5		8.0	
Delta of TX Pre-emphasis TX_EQL[2]/TX_EQL[1]	$\Delta_{EQL_2_1_HBR3_2}$	dB	0.7			
Delta of TX Pre-emphasis TX_EQL[3]/TX_EQL[2]	$\Delta_{EQL_3_2_HBR3_2}$	dB	0.7			
HBR/RBR transmitter TP2 parameters						
Ratio of Output Voltage Level 1/Level 0	$R_{VSL_1_0_HBR_RBR}$	dB	0.8		6.0	Measured on non-transition bits at Pre-emphasis Level 0 setting.
Ratio of Output Voltage Level 2/Level 1	$R_{VSL_2_1_HBR_RBR}$	dB	0.1		5.1	
Ratio of Output Voltage Level 3/Level 2	$R_{VSL_3_2_HBR_RBR}$	dB	0.8		6.0	
Maximum Pre-emphasis when disabled	$R_{EQ_DISABLE}$	dB			0.25	
Delta of Pre-emphasis Level 1 vs. Level 0	$\Delta_{EQL_1_0_HBR_RBR}$	dB	2			
Delta of Pre-emphasis Level 2 vs. Level 1	$\Delta_{EQL_2_1_HBR_RBR}$	dB	1.6			
Delta of Pre-emphasis Level 3 vs. Level 2	$\Delta_{EQL_3_2_HBR_RBR}$	dB	1.6			
HBR3 transmitter TP3_CTLE parameters						
Total jitter	$T_{TX_TJ_TPS4_HBR3}$	mUI			470	Measured at BER 10 ⁻⁶ with TPS4
Non-ISI jitter	$J_{TX_NonISI_TPS4_HBR3}$	mUI			230	Measured at BER 10 ⁻⁶ with TPS4
Eye height	V_{HEIGHT_HBR3}	mV	65			
HBR2 transmitter TP3_EQ parameters						
Total jitter	$T_{TX_TJ_CP2520_HBR2}$	mUI			620	Measured at BER 10 ⁻⁹ with CP2520
Random Jitter	RJ_HBR2	mUI			230	
Eye height	V_{HEIGHT_HBR2}	mV	90			

7.5.3. DisplayPort receiver

AC characteristics parameters are guaranteed by the silicon characterization across operating condition unless otherwise specified. Not all parameters are tested in the production test.

Table 24. DisplayPort receiver characteristics

Parameter	Symbol	Unit	Min	Typ	Max	Comments
DisplayPort Main-Link receiver system parameters						
Termination control range	R _{TX_TERM_RANGE}	ohm	80		120	
Frequency for high bit rate 3	f _{HBR3}	Gbps		8.1		
Frequency for high bit rate 2	f _{HBR2}	Gbps		5.4		
Frequency for high bit rate	f _{HBR}	Gbps		2.7		
Frequency for reduced bit rate	f _{RBR}	Gbps		1.62		
Link clock down-spreading amplitude	SSC _{DPTX_AMP}	%	0		0.5	
Link clock down-spreading frequency	SSC _{DPTX_FREQ}	kHz	30		33	
HBR3 DisplayPort Main-Link Receiver TP3_EQ parameters						
Minimum Receiver Eye width	T _{HBR3_EYE_TPS3EQ}	mUI	380			Measured at 10 ⁻⁶ BER
RX differential peak-to-peak Eye voltage	V _{RX_DIF_PP_MIN_HBR3}	mV	40			
Random Jitter	T _{RX_RJ_TPS4_HBR3}	mUI			123	
Minimum Receiver Non-ISI jitter	T _{RX_NON_ISI_HBR3}	mUI			380	
HBR2 DisplayPort Main-Link Receiver TP3_EQ parameters						
Minimum Receiver Eye width	T _{HBR2_EYE_TPS3EQ}	mUI	380			Measured at 10 ⁻⁹ BER
RX differential peak-to-peak Eye voltage	V _{RX_DIF_PP_MIN_HBR2}	mV	70			
HBR DisplayPort Main-Link Receiver TP3_EQ parameters						
Minimum Receiver Eye width	T _{HBR_EYE_TPS3EQ}	mUI	509			Measured at 10 ⁻⁹ BER
RX differential peak-to-peak Eye voltage	V _{RX_DIF_PP_MIN_HBR}	mV	150			
RBR DisplayPort Main-Link Receiver TP3 parameters						
Minimum Receiver Eye width	T _{HBR_EYE_TPS3EQ}	mUI	250			Measured at 10 ⁻⁹ BER
RX differential peak-to-peak Eye voltage	V _{RX_DIF_PP_MIN_HBR}	mV	46			

7.5.4. DisplayPort AUX_CH

AC characteristics parameters are guaranteed by the silicon characterization across operating condition unless otherwise specified. Not all parameters are tested in the production test.

Parameter	Symbol	Unit	Min	Typ	Max	Comments
Manchester transaction unit interval	UI _{AUX_MAN}	μs	0.4		0.6	
Number of pre-charge pulses	N _{PRE_CHARGE_PULSE}		10		16	
AUX CH bus park time	T _{AUX_BUS_PARK}	ns	10			
AUX peak-to-peak voltage at transmitter	V _{AUX_DIFFp-p_TX}	V	0.29	0.40	1.38	
AUX peak-to-peak voltage at receiver	V _{AUX_DIFFp-p_RX}	V	0.27		1.36	
AUX CH termination	R _{AUX_TERM}	ohm		100		
AUX_DC common mode voltage	V _{AUX_TURN_CM}	V	0		3.6	
AUX turn-around common mode voltage	V _{AUX_TURN_CM}	V			0.3	
AC coupling capacitor	C _{AUX}	nF	75		200	

7.5.5. USB 3.2 x1 transmitter

AC characteristics parameters are guaranteed by the silicon characterization across operating condition unless otherwise specified. Not all parameters are tested in the production test.

Table 25. USB 3.2 x1 transmitter characteristics

Parameter	Symbol	Unit	Min	Typ	Max	Comments
USB 3.2 x1 transmitter (SSRX pin and Type-C interface in USB mode)						
Unit interval in Gen1	U _{USB_GEN1}	ps	199.94		200.46	
Unit interval in Gen2	U _{USB_GEN2}	ps	99.97		100.03	
AC coupling capacitor	C _{TX_USB}	nF	75		265	
SSC deviation	t _{SSC_FREQ_DEVIATION}	ppm	0		-5000	
Modulation rate	t _{SSC_MOD_RATE}	kHz	30		33	
Differential peak-to-peak voltage swing	V _{USB_TX_DIFF_PP}	V	0.8		1.0	
De-emphasis in Gen1	V _{TX_DE_RATIO_GEN1}	dB	3.0		4.0	
Preshoot in Gen2	V _{TX_PS_RATIO}	dB	1.2		3.2	
De-emphasis in Gen2	V _{TX_DE_RATIO_GEN2}	dB	2.1		4.1	
DC differential impedance	R _{TX_DIFF_DC}	Ohm	72		120	
The amount of voltage change during Rx detection	V _{TX_RCV_DETECT}	V			0.6	
Maximum slew rate	t _{CDR_SLEW_RATE}	ms/S			10	In Gen1
SSC df/dt	SSC _{dfdt}	ppm/μs			1250	In Gen2
Eye height at TP4 in Gen1	V _{EYE_HEIGHT_GEN1}	mV	100		1000	
Eye height at TP4 in Gen2	V _{EYE_HEIGHT_GEN2}	mV	70		1000	
Deterministic jitter at TP4 in Gen1	D _{JUSB_GEN1}	mUI			430	
Deterministic jitter at TP4 in Gen2	D _{JUSB_GEN2}	mUI			530	
RMS Random jitter at TP4 in Gen1	R _{JUSB_GEN1}	ps			3.22	
RMS Deterministic jitter at TP4 in Gen2	D _{JUSB_GEN2}	ps			1	
Total jitter at TP4 in Gen1	T _{JUSB_GEN1}	mUI			660	
Total jitter at TP4 in Gen2	T _{JUSB_GEN1}	mUI			671	

Parameter	Symbol	Unit	Min	Typ	Max	Comments
LFPS tPeriod	tPeriod	ns	20		80	
LFPS peak-to-peak differential amplitude	V _{TX_DIFF_PP_LFPS}	mV	800		1000	
LFPS duty cycle	T _{DUTY_LFPS}	%	40		60	

7.5.6. USB 3.2 x1 receiver

AC characteristics parameters are guaranteed by the silicon characterization across operating condition unless otherwise specified. Not all parameters are tested in the production test.

Table 26. USB 3.2 x1 receiver characteristics

Parameter	Symbol	Unit	Min	Typ	Max	Comments
USB 3.2 x1 receiver (SSTX pin and Type-C interface in USB mode)						
Unit interval in Gen1	U _{USB_GEN1}	ps	199.94		200.46	
Unit interval in Gen2	U _{USB_GEN2}	ps	99.97		100.23	
SSC deviation	t _{SSC_FREQ_DEVIATION}	ppm	0		-5000	
Modulation rate	t _{SSC_MOD_RATE}	kHz	30		33	
Receiver DC common mode impedance	R _{RX_DC}	ohm	18		30	
DC differential impedance	R _{RX_DIFF_DC}	ohm	72		120	
Receiver high-impedance	Z _{RX_HIGH_IMP_DC_POS}	ohm	10k			
LFPS detect threshold	V _{RX_LFPS_DET_DIFFp-p}	mV	100		300	

7.5.7. TWI Timing

Table 27. TWI Timing

Symbol	Parameter	Min	Max	Unit
F _{SCL}	SCL Clock Frequency	400	1000	KHz
t _{SP}	Pulse width of spikes that must be suppressed by the input filter		50	ns
t _{LOW}	LOW period of the SCL clock	0.5	-	μs
t _{HIGH}	HIGH period of the SCL clock	0.26	-	μs
t _{HD:DAT}	Data hold time	0	-	μs
t _{SU:DAT}	Data set-up time	50	-	ns
t _R	Rise time of both SDA and SCL signals	-	120	ns
t _F	Fall time of both SDA and SCL signals	20x (VDD /5.5)	120	ns
t _{BUF}	Bus free time between a STOP and START condition	0.5	-	μs
C _B	Capacitance load for each bus line	-	550	pF
t _{VD:DAT}	Data valid time	-	0.45	μs
t _{VD:ACK}	Data valid acknowledge time	-	0.45	μs

8. Ordering Information

Part Number	Operating Temperature	Package
MCDP6000C1	0°C to +70°C	Ex-VQFN46

9. References

1. Universal Serial Bus 3.2 Specification Revision 1.0 Sep 22, 2017
2. Universal Serial Bus Type-C Cable and Connector Specification Revision 1.3 July 4, 2017
3. VESA DisplayPort (DP) Standard Version 1.4a 19 April, 2018
4. VESA DisplayPort Alt Mode on USB Type-C Standard Version 1.0 22 September, 2014
5. EIAJ ED-5003A

Mouser Electronics

Authorized Distributor

Click to View Pricing, Inventory, Delivery & Lifecycle Information:

[Kinetic Technologies:](#)

[MCDP6000C1](#) [RD4-6000](#)