

700mA HIGH VOLTAGE ADJUSTABLE CURRENT REGULATOR WITH ENABLE CONTROL

DESCRIPTION

The AMC7140 is a high voltage, low drop-out current regulator for maximum output current up to 700mA. The output current was decided by external resistor. The output sink current could be disabled via OE pin

Build-in thermal protection to prevent the chip over heat damage.

FEATURES

- 0.5V Output Drop-out Voltage at 700mA.
- 700mA Maximum Output Current.
- Output Current Controlled by External Resistor.
- 3us Fast Response Output Stage Enable Control.
- Output Driving Voltage Up To 75V.
- Supply Voltage Range 5V~50V
- TO-252-5L package

TYPICAL APPLICATION CIRCUIT

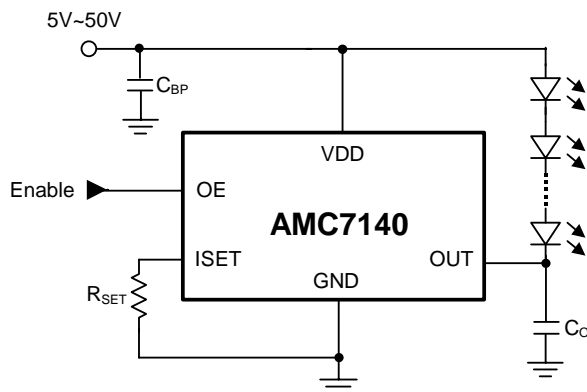

APPLICATIONS

- High Power LED Driver
- RGB Full Color Power LED driver
- LCD Monitor/TV LED backlight Driver
- LED Table Lamp

PACKAGE PIN OUT

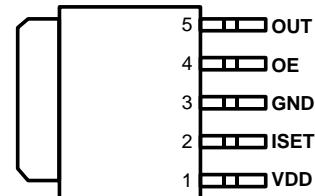

TO-252-5L
(Top View)

ORDER INFORMATION

	DL	TO-252
		5 pin
Lead Free		AMC7140DLFT
Green		AMC7140DLGT
Note: Part Number: A M C 7 1 4 0 		
Package Type.	DL: TO-252-5L ←	 → Packing. T: Tape & Reel; N/A: Bulk → Package Process. F: Lead Free; G: Green

ABSOLUTE MAXIMUM RATINGS (Note)

Input Voltage, V_{DD}	50V
Output Voltage, V_{OUT}	75V
Enable Voltage, V_{OE}	13.2V
Maximum Operating Junction Temperature, T_J	150°C
Storage Temperature Range	-65°C to 150°C
Lead Temperature (soldering, 10 seconds)	260°C
Note: Exceeding these ratings could cause damage to the device. All voltages are with respect to Ground. Currents are positive into, negative out of the specified terminal.	

PIN DESCRIPTION

Pin Name	Pin Function
OUT	Output pin. Sink current is decided by the current on R_{SET} connected to I_{SET} . $I_{OUT} = 500 \times I_{SET}$.
OE	Output stage enable control pin. High enable the OUT pin. It can be left floating for normally on.
I_{SET}	Output current set input. Connect a resistor from I_{SET} to GND to set the LED bias current. $I_{SET} = 1.2V/R_{SET}$.
VDD	Power supply.
GND	Ground

THERMAL DATA

Thermal Resistance from Junction to Ambient, θ_{JA}	80 °C /W
Junction Temperature Calculation: $T_J = T_A + (P_D \times \theta_{JA})$. The θ_{JA} numbers are guidelines for the thermal performance of the device/pc-board system. Connect the ground pin to ground using a large pad or ground plane for better heat dissipation. All of the above assume no ambient airflow.	

Maximum Power Calculation:

$$P_{D(MAX)} = \frac{T_{J(MAX)} - T_{A(MAX)}}{\theta_{JA}}$$

T_J (°C): Maximum recommended junction temperature

T_A (°C): Ambient temperature of the application

θ_{JA} (°C /W): Junction-to-Ambient temperature thermal resistance of the package, and other heat dissipating materials.

The maximum power dissipation for a single-output regulator is:

$$P_{D(MAX)} = [(V_{IN(MAX)} - V_{OUT(NOM)}) \times I_{OUT(NOM)} + V_{IN(MAX)} \times I_Q]$$

Where: $V_{OUT(NOM)}$ = the nominal output voltage
 $I_{OUT(NOM)}$ = the nominal output current, and
 I_Q = the quiescent current the regulator consumes at $I_{OUT(MAX)}$
 $V_{IN(MAX)}$ = the maximum input voltage

Then $\theta_{JA} = (+150^\circ\text{C} - T_A)/P_D$

RECOMMENDED OPERATING CONDITIONS

Parameter	Symbol	Min	Typ	Max	Unit
Supply Voltage	V_{DD}	5		50	V
Output Enable Voltage	V_{OE}			12	V
Output Sink Current	I_{OUT}	100		700	mA
Operating free-air temperature range	T_a	-40		+85	°C

DC ELECTRICAL CHARACTERISTICS

$V_{DD}=24V$, $T_a=25^{\circ}C$, No Load, (Unless otherwise noted)					
Parameter	Condition	Min	Typ	Max	Unit
Output Current	$V_{OUT}=0.5V$, $R_{SET}=4K\Omega$		150		mA
	$V_{OUT}=0.5V$, $R_{SET}=1.2K\Omega$		500		
Output Current Deviation	$V_{OUT}=0.5V$, $R_{SET}=4K\Omega$			± 5	%
	$V_{OUT}=0.5V$, $R_{SET}=1.2K\Omega$			± 5	
SET Current Range		200		1400	μA
Maximum Output Current	$I_{SET}=1400\mu A$		700		mA
Output Drop-out Voltage*	$I_{SET}=1000\mu A$, Note 1		0.35		V
Load Regulation	$V_{OUT}=0.5V$ to 3V			3	mA/V
Line Regulation	$V_{OUT}=0.5V$, $I_{OUT}=350mA$ $V_{DD}=5V$ to 50V,			1	mA/V
Thermal Shut-down Junction Temperature	Hysteresis 20°C		160		°C
“Low” Input Voltage		0		0.8	V
“High” Input Voltage		2		Min { V_{DD} , 12}	V
“Low” Input Current		-20		+20	μA
“High” Input Current		-5.0		+5.0	μA
Output Enable Delay Time	OE from Low to High, $V_{OUT}=0.5V$, $I_{OUT}=350mA$, 50%		3		μS
Output Disable Delay Time	OE from High to Low, $V_{OUT}=0.5V$, $I_{OUT}=350mA$, 50%		3		μS
Supply Current Consumption				5	mA

Note1: Output dropout voltage: $90\% \times I_{OUT}$ @ $V_{OUT}=500mV$

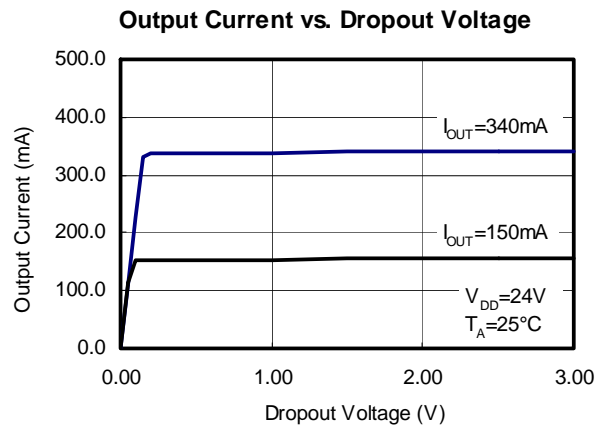
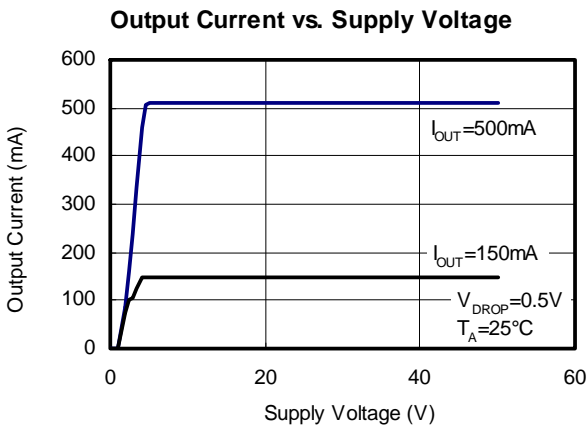
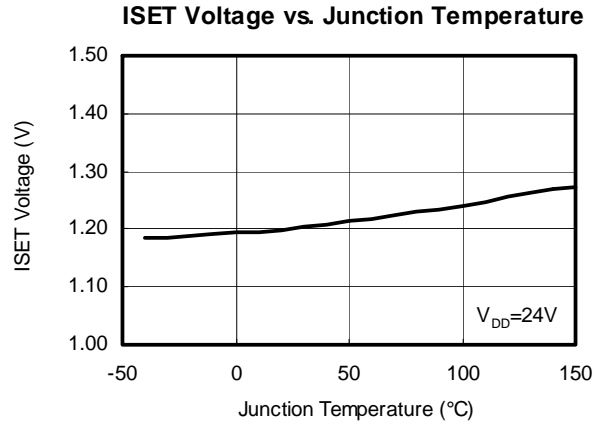
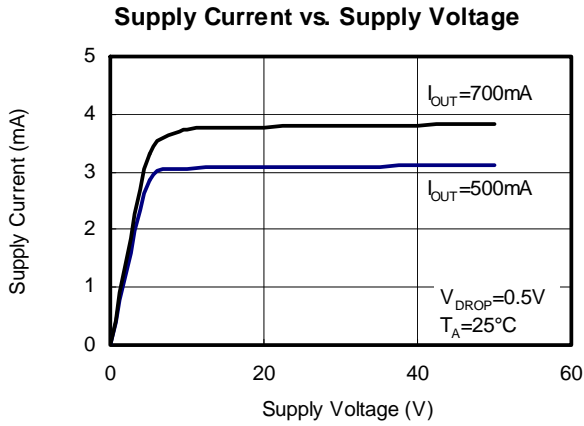
CHARACTERIZATION CURVES

APPLICATION INFORMATION

AMC7140 is a high voltage, low dropout current regulator for maximum output current up to 700mA with OE pin. The current could be linearly adjusted through variable resistor connected to I_{SET} pin, or by PWM control via OE pin. Although the absolute maximum rating of OUT pin 60V, the dropout voltage between OUT pin and GND pin should not be too large when current is sinking because of the heat dissipation capability of the package.

Here are some of the typical application examples:

DC Voltage Input:

Any DC voltage level between 5V to 50V could be adopted as power source V_{DD} for typical application of AMC7140 as long as V_{DD} is larger than the total forward voltage drop of the LED string (at expecting current) by 0.35V. If 50V ~ 60V voltage level is adopted as power source to positive end of the LED string, one Zener shunt regulator could be used to provide appropriate voltage to V_{DD} pin.

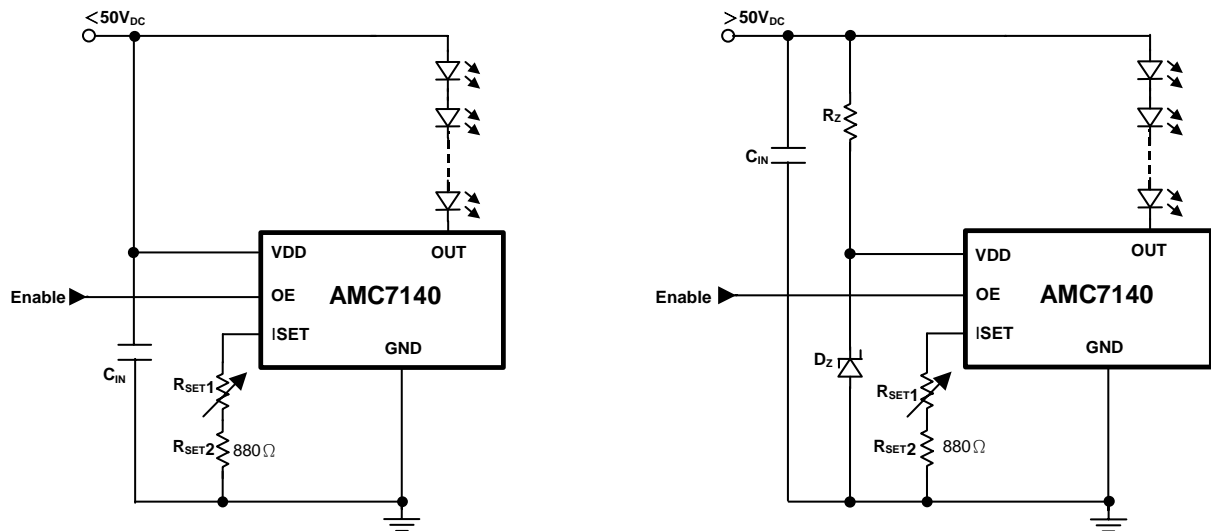

LED Backlight Solution:

AMC7140 could coordinate with any type of DC-to-DC converter through feedback path to realized LED backlight module. The number of LEDs in the string is variable even with certain fixed power source since the output voltage of the DC-to-DC converter could be modulated according to feedback signal.

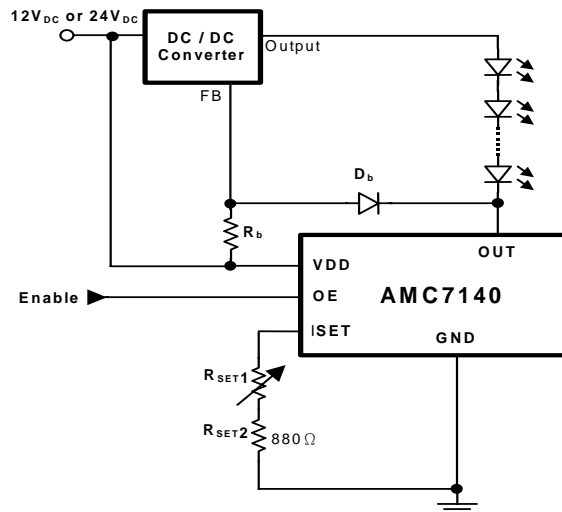
AC Voltage Input:

AMC7140 could work with any kind of well-known or well-developed switch-mode power supply system. Simply cut off the internal feedback path of the power supply system and then feed the signal from AMC7140 back to the power supply system instead.

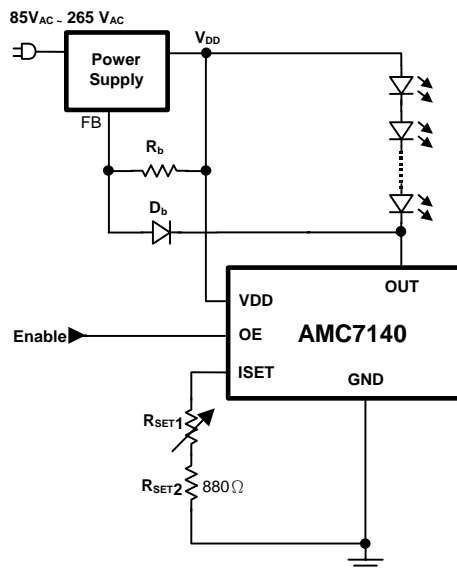

THERMAL CONSIDERATION
The Maximum Power Dissipation on Current Regulator:

$$P_{D(MAX)} = V_{OUT(MAX)} \times I_{OUT(NOM)} + V_{IN(MAX)} \times I_{DD}$$

$V_{OUT(MAX)}$ = the maximum voltage on output pin;

$I_{OUT(NOM)}$ = the nominal output current;

I_{DD} = the quiescent current the regulator consumes at $I_{OUT(NOM)}$;

$V_{IN(MAX)}$ = the maximum input voltage.

Thermal Consideration:

The AMC7140 has internal power and thermal limiting circuitry designed to protect the device under overload conditions. However, maximum junction temperature ratings should not be exceeded under continuous normal load conditions. The thermal protection circuit of AMC7140 prevents the device from damage due to excessive power dissipation. When the device junction temperature rises to approximately 150°C, the regulator will be turned off. When power consumption is over about 1000mW (TO-252 package, at $T_A=70^\circ\text{C}$), additional heat sink is required to control the junction temperature below 125°C.

The junction temperature is:

$$T_J = P_D (\theta_{JT} + \theta_{CS} + \theta_{SA}) + T_A$$

P_D : Dissipated power.

θ_{JT} : Thermal resistance from the junction to the mounting tab of the package.

For TO-252 package, $\theta_{JT} = 7.0 \text{ }^\circ\text{C/W}$.

θ_{CS} : Thermal resistance through the interface between the IC and the surface on which it is mounted.
(typically, $\theta_{CS} < 1.0^\circ\text{C/W}$)

θ_{SA} : Thermal resistance from the mounting surface to ambient (thermal resistance of the heat sink).

If PC Board copper is going to be used as a heat sink, below table can be used to determine the appropriate size of copper foil required. For multi-layered PCB, these layers can also be used as a heat sink. They can be connected with several through-hole vias.

PCB θ_{SA} ($^\circ\text{C/W}$)	59	45	38	33	27	24	21
PCB heat sink size (mm^2)	500	1000	1500	2000	3000	4000	5000

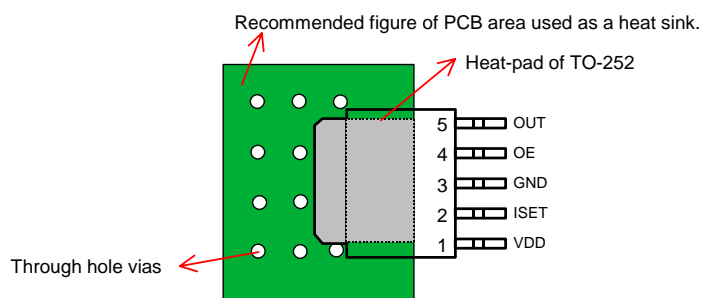

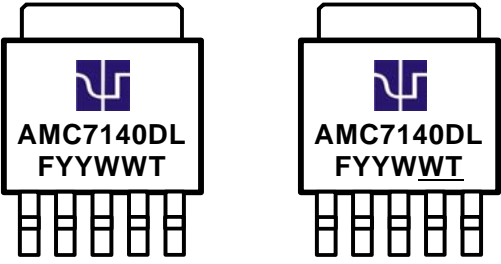
PACKAGE
Top Marking For TO-252 5-Pin

DL: TO-252 Package Type
 F : Control Code
 YY : Year Code
 WW : Week Code
 T : Trace Code
 _ : Green Part

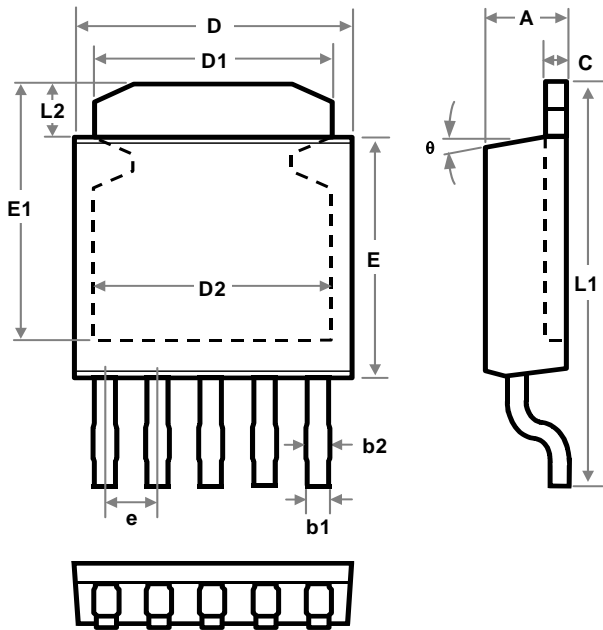
TO-252-5L

Symbol	Dimensions in Millimeters	
	MIN	MAX
A	2.200	2.400
b1	0.584	0.660
b2	0.635	0.787
C	0.483	0.584
D	6.350	6.650
D1	5.200	5.436
D2	4.902	5.004
E	5.400	6.200
E1	5.415	5.615
e	1.270 BSC	
L1	9.500	10.210
L2	1.100 REF	
θ	7° REF	

IMPORTANT NOTICE

ADDtek reserves the right to make changes to its products or to discontinue any integrated circuit product or service without notice, and advises its customers to obtain the latest version of relevant information to verify, before placing orders, that the information being relied on is current.

A few applications using integrated circuit products may involve potential risks of death, personal injury, or severe property or environmental damage. ADDtek integrated circuit products are not designed, intended, authorized, or warranted to be suitable for use in life-support applications, devices or systems or other critical applications. Use of ADDtek products in such applications is understood to be fully at the risk of the customer. In order to minimize risks associated with the customer's applications, the customer should provide adequate design and operating safeguards.

ADDtek assumes no liability to customer product design or application support. ADDtek warrants the performance of its products to the specifications applicable at the time of sale.

ADDtek Corp.

9F, No. 20, Sec. 3, Bade Rd., Taipei, Taiwan, 105

TEL: 2-25700299

FAX: 2-25700196
