

MARKETING SALES DRAWING

DIMENSIONS IN INCHES - DO NOT SCALE THIS DRAWING  
 DIMENSIONS IN METRIC [ ]

Electrical Testing  
 per Tusonix standard  
 test plans and Mil-Std-202  
 Test Methods.

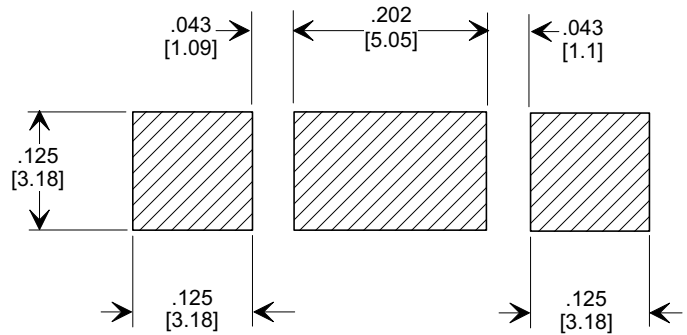
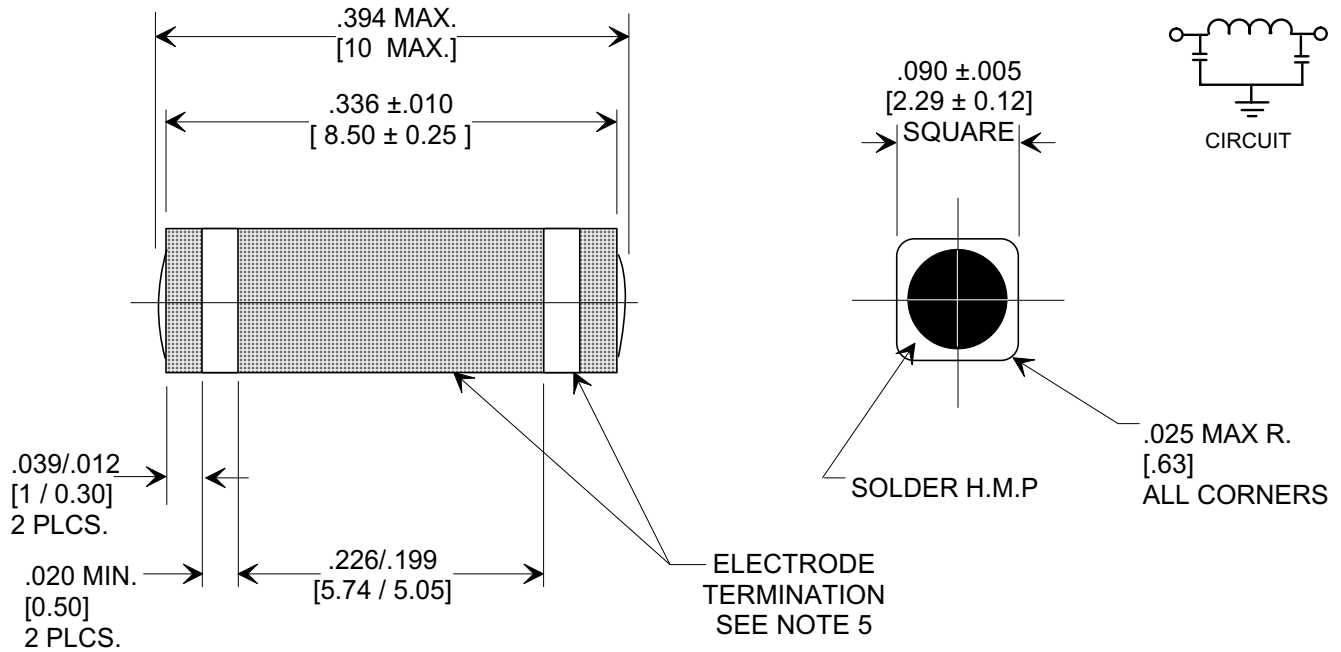
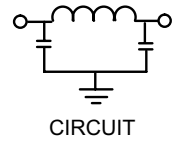
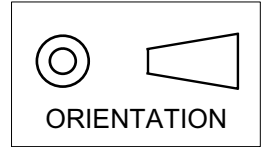

SUGGESTED MOUNTING PATTERN  
 (SACLE 5 X)

NOTES:

1. INDUCTANCE TO BE 0.1 H MINIMUM.
2. PACKAGE: BULK OR BLISTER TAPE TO IEC-286-3 TYPE II AND EIA-481-A.
3. TUSONIX STANDARD PART NUMBER: 4701-001.  
 TUSONIX RoHS COMPLIANT PART NUMBER: 4701-001 LF.  
 CUSTOMER MUST SPECIFY STANDARD OR RoHS PART NUMBER WHEN ORDERING.
4. PART MARKING: STANDARD PART: NO MARKING. RoHS PART: LABELED ON PACKAGING ONLY.
5. ELECTRODE TERMINATION: 60/40 SOLDER: RoHS COMPLIANT: MATTE TIN.

CAP.	TOLERANCE	WVDC +85°C	TEST VOLTAGE	I.R.MIN. @ 100 (VDC.)	IDC	ELECTRODE TERMINATION	TYPICAL NO LOAD INSERTION LOSS dB AT 25°C PER MIL-STD-220		
							10 MHZ	100 MHZ	1 GHZ
8,200 pF	+80% / -20%	100	300 VDC	10 G	10 A	SOLDER	20	65	70

X-2015 Rev-0

REVISION RECORD	Original Release C.O. <b>950911-2</b>	Title <b>SURFACE MOUNT SQUARE STYLE PI FILTER</b>	Drawn EC 08-11-95	Scale 7 X
	<b>6</b> REVISED DWG. DRAWING MADE FOR EACH VAR. S.M. 02-13-03			
	<b>7</b> REVISED DRAWING. S.M. 06-23-03			
	<b>8</b> ADDED NOTES 3,4 & 5. S.M. 06-23-05			
<b>9</b> <b>20050617-3-02</b>		Approved NV 08-11-95		
--TOLERANCES-- Unless Otherwise Specified DECIMAL ± .005 [0.10] ANGLES ±		<b>TUSONIX</b> TUCSON, ARIZONA		
		<b>A</b>	<b>4701-001</b>	

# Mouser Electronics

Authorized Distributor

Click to View Pricing, Inventory, Delivery & Lifecycle Information:

[Tusonix / CTS:](#)

[4701-001MLF](#)