

Visual Signals - Industrial LIGHT EMITTING DIODE BEACONS



Industrial LED Beacons > LED195 Series

Product overview

The LED195 beacon has been designed for industrial & commercial signalling applications where low maintenance & long life are the pre-requisite requirement.

These beacons have two stages of alarm, flashing (pre-set to either 60 or 120 FPM) or continuous (static) mode, selectable by a jumper link on the PCB. The design also allows for a third wire

connection giving the flexibility to switch from a pre-set static mode to a pre-set flashing mode.

The design allows for termination inside the enclosure. The LED195 deep base version offers 2 x M20 side knockouts and 1 x M20 rear.

The shallow base (low profile version) allows for cable entry of up to 5mm on the side of the unit (x2) and 1 x M20 knockout at the rear.

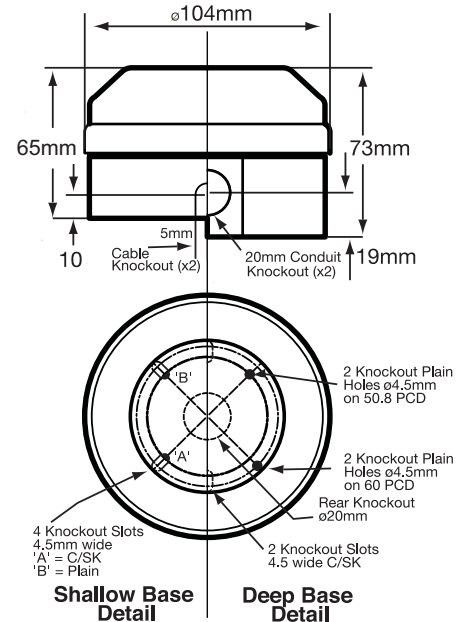

LED195 Series > Ordering Information

Code No:	Voltage:	Light Source:	Current:
LED195-01WH-SB	8-20v Ac/Dc ~	36 SMT LEDs	240 mA @ 12v Dc
LED195-01WH	8-20v Ac/Dc ~	36 SMT LEDs	240 mA
LED195-02WH-SB	20-30v Ac/Dc ~	36 SMT LEDs	120 mA @ 24v Dc
LED195-02WH	20-30v Ac/Dc ~	36 SMT LEDs	120 mA
LED195-03WH-SB	35-85v Ac/Dc ~	36 SMT LEDs	76 mA @ 48v Dc
LED195-03WH	35-85v Ac/Dc ~	36 SMT LEDs	76 mA
LED195-05WH-SB	40-380v Dc --- 85-280v Ac ~	36 SMT LEDs	35 mA @ 230v Ac
LED195-05WH	40-380v Dc --- 85-280v Ac ~	36 SMT LEDs	35 mA

Features

- Continuously rated
- LED Long Life
- Suitable for conduit box or wall mounting
- 120° prime light output above the vertical axis
- WH = White back box
- SB = Shallow base
- Dustproof and Weatherproof

Material

UV Stable Polycarbonate Lens
UV Stable ABS Plastic Base

Kg 0.25

50/60 Hz

°C -25+55

IP 65

FPM 60/120

INDUSTRIAL

APPROVALS and
CONFORMITIES

