

Jan.1.2022 Copyright 2022 HIROSE ELECTRIC CO., LTD. All Rights Reserved.
In case of consideration for using Automotive equipment / device which demand high reliability, kindly contact our sales window correspondents.

COUNT	DESCRIPTION OF REVISIONS	BY	CHKD	DATE	COUNT	DESCRIPTION OF REVISIONS	BY	CHKD	DATE
1	DIS-C-000585	T.K	E,K	07.07.27					

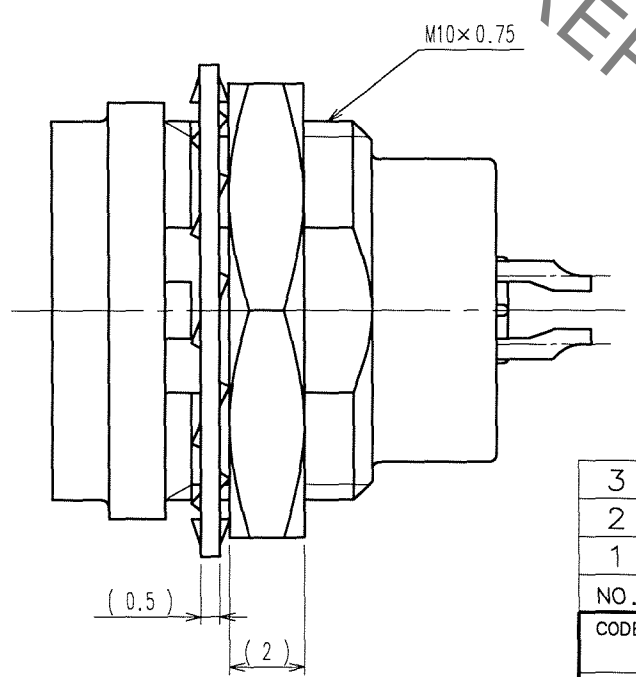
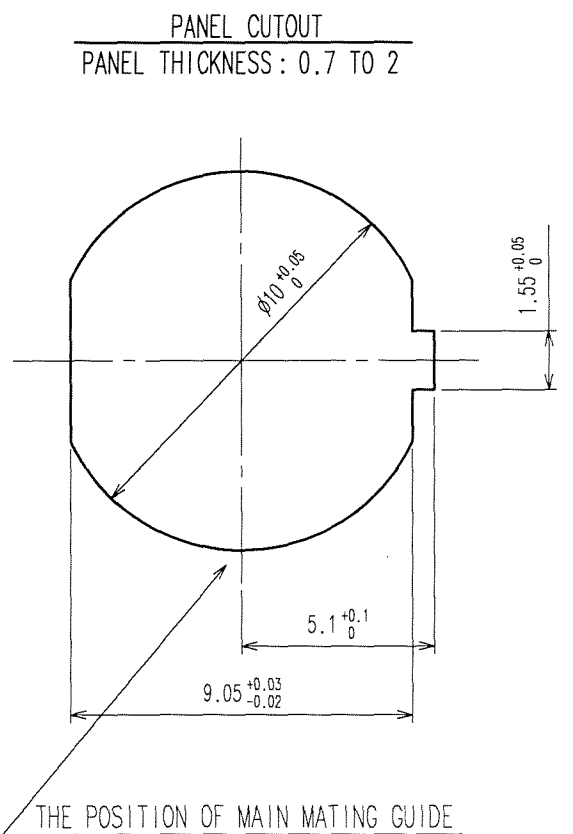
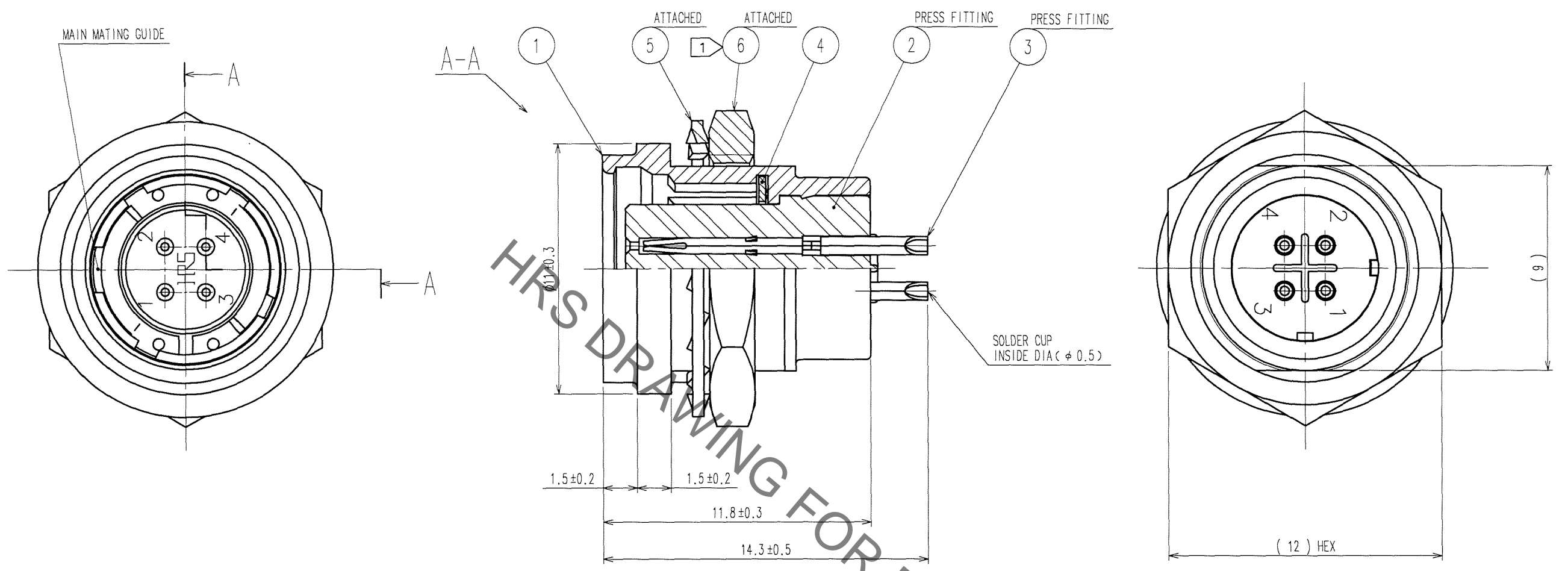

NOTES

- THE RECOMMENDED TIGHTENING TORQUE OF REF. No. ⑥ TO BE 1 N·m. COATING WITH LOCTITE 242 MANUFACTURED BY HENKEL JAPAN OR EQUIVALENT IS RECOMMENDED TO PREVENT LOOSENESS.
- CONTACT AREA : GOLD 0.2μ m min.
TERMINAL AREA : GOLD FLASH.
UNDER PLATING : NICKEL 2μ m min.

NO.	MATERIAL	FINISH, REMARKS	NO.	MATERIAL	FINISH, REMARKS
3	PHOSPHOR BRONZE	②	6	BRASS ①	NICKEL PLATING
2	POLYPHENYLENE SULFIDE (BLACK) 94V-0		5	PHOSPHOR BRONZE	NICKEL PLATING
1	ZINC ALLOY	MATTE FINISH NICKEL PLATING	4	BERYLLIUM COPPER	NICKEL PLATING

CODE NO. (OLD)	DRAWN	DESIGNED	CHECKED	APPROVED	RELEASED
CL	M.SATO	Y.YAMADA		M.SATO	
	'06 09 27	'06 09 28		'06 09 29	

SCALE	DRAWING NO.	PART NO.
5 : 1	EDC3-115064	HR25A-7R-4S
UNITS	HIROSE ELECTRIC CO., LTD	CODE NO.
mm		CL125-0622-5-00

TO
R

1/1

Mouser Electronics

Authorized Distributor

Click to View Pricing, Inventory, Delivery & Lifecycle Information:

[Hirose Electric:](#)

[HR25A-7R-4S](#)