

NOTES:

1. MAX Electrical Rating: 250 Volts, 100 Watts
2. Use with G4, GX5.3 or G6.35 Style lamps/L.E.D.s
3. Contact retention force 2.0-4.0 lbs per contact
4. Two Pan Head 5-40 Screws to be supplied with each socket.
5. Ceramic Body Socket

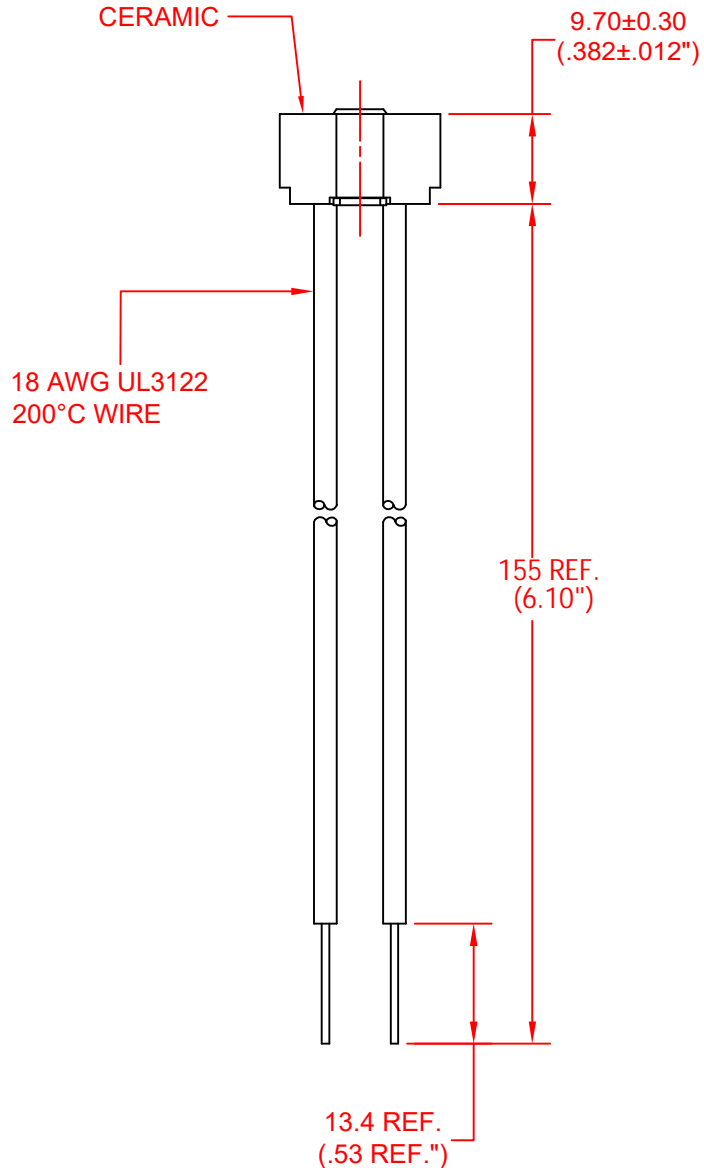
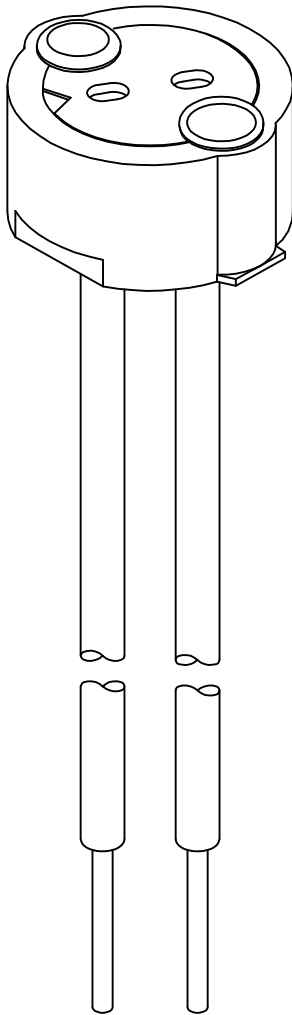
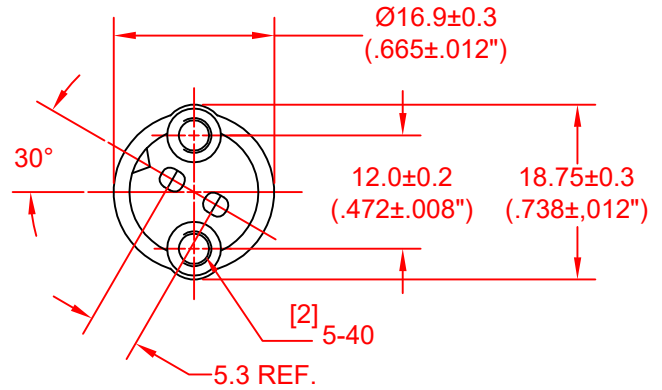

G	ADD NOTE 5, ADD "MAX" VALUE NOTE 1	9/08/21
F	CHNG LEADS 155 REF.	3/31/21
E	CHNG.DIMS 9.7 O& 154.2 TOLERANCE	8/21/18
D	ADD NOTE 4	11/9/17
C	ADD NOTES	2/11/13
B	CHANGE DIM 17.2 to 16.9	1/11/11
A	ADD PIN SPACING DIMENSION	10/31/08
	RELEASED	11/26/07

<p>THIRD ANGLE PROJECTION</p>	<p>METRIC</p> <p>DIMENSIONS ARE IN MILLIMETERS</p> <p>TOLERANCE UNLESS OTHERWISE SPECIFIED</p> <p>1 PL +/- REF.</p> <p>2 PL +/- REF.</p> <p>ANGLE +/-</p>	<p>JKL COMPONENTS CORPORATION</p>				
	<p>TITLE</p> <p>MR16 LAMP SOCKET</p>					
<p>DRAWN BY</p> <p>L. WENGSTROM</p>	<p>APPV'D BY</p> <p>S.N. 9/8/21</p>	<p>DATE</p> <p>9/8/21</p>	<p>SIZE</p> <p>NONE</p>	<p>FSCM NO.</p>	<p>DRAWING NO.</p> <p>2993-G5</p>	
<p>- CAD DRAWING -</p> <p>MANUAL REVISIONS NOT PERMITTED</p>		<p>SCALE</p> <p>NONE</p>	<p>RELEASED DATE</p> <p>11/26/07</p>	<p>REVISION DATE</p> <p>9/8/21</p>	<p>REV. NO.</p> <p>G</p>	<p>SHEET</p> <p>1 OF 1</p>

Mouser Electronics

Authorized Distributor

Click to View Pricing, Inventory, Delivery & Lifecycle Information:

[JKL Components:](#)

[2993-G5](#)