

Jan.1.2022 Copyright 2022 HIROSE ELECTRIC CO., LTD. All Rights Reserved.
In case of consideration for using Automotive equipment / device which demand high reliability, kindly contact our sales window correspondents.

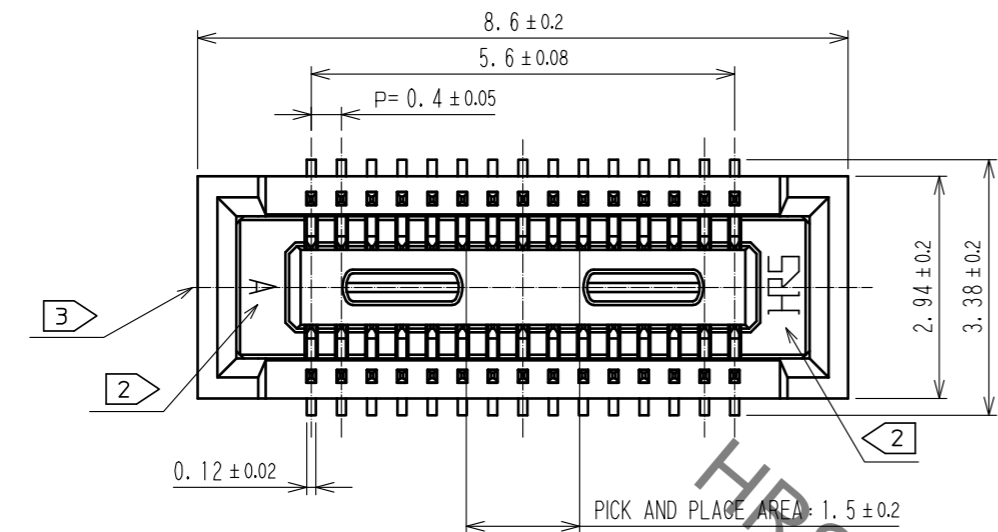

RECOMMENDED PATTERN

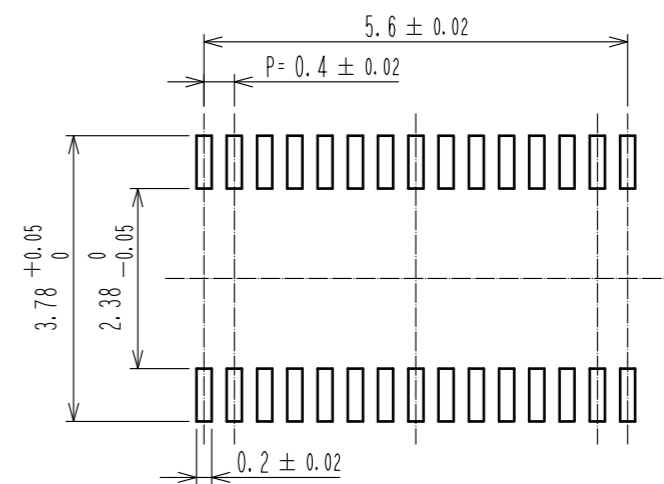

RECOMMENDED METAL MASK THICKNESS : 120 μm
RECOMMENDED METAL MASK OPENING RATIO : 80% FOR LEAD PAD

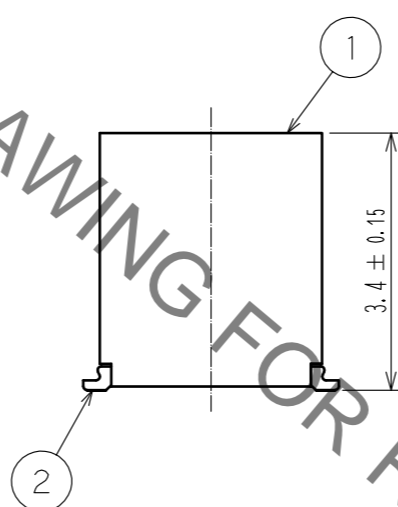
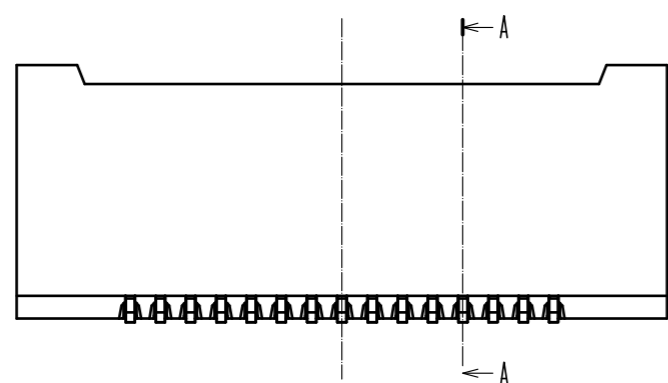

ENGAGEMENT FIGURE (20:1)

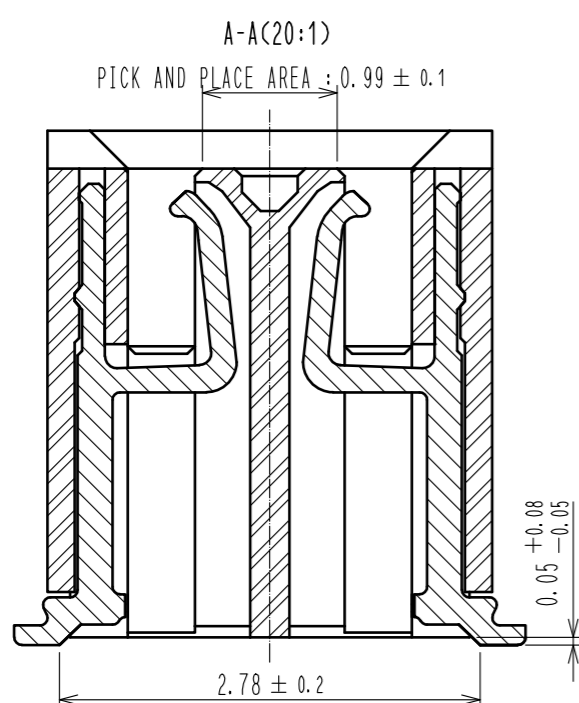
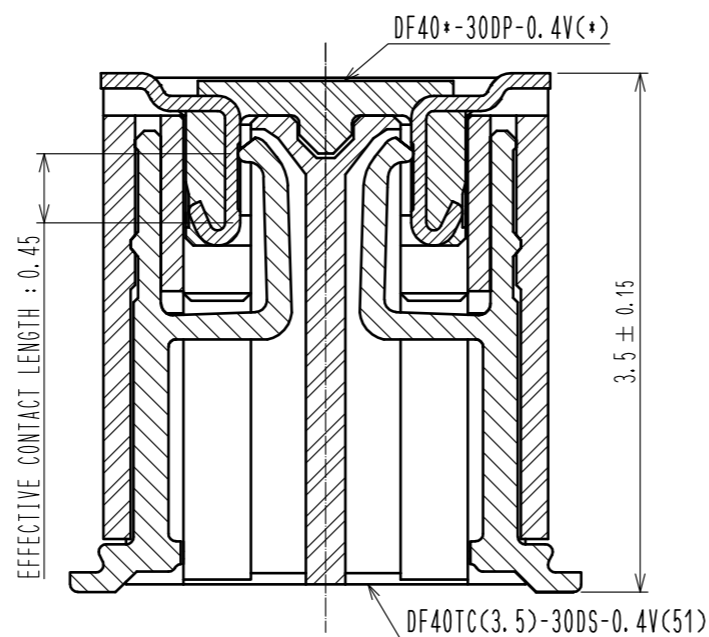

- NOTES) 1. ALL LEADS CO-PLANARITY SHALL BE 0.1 MAX.
2. HRS MARK AND CAV NO. ARE LOCATED IN APPROXIMAL AREA.
3. GATE IS LOCATED IN APPROXIMAL AREA.

2	COPPER ALLOY	CONTACT AREA:GOLD 0.05 μm MIN SMT LEAD:GOLD 0.05 μm MIN UNDERPLATING:NICKEL 1 μm MIN	6	PS	CLEAR, REINFORCEMENT COLLAR
			5	PS	BLACK
			4	POLYESTER	CLEAR, COVER TAPE
1	LCP	BLACK, UL94V-0	3	PS	CLEAR, EMBOSSED CARRIER TAPE
NO.	MATERIAL	FINISH, REMARKS	NO.	MATERIAL	FINISH, REMARKS
UNITS mm		SCALE 10:1	COUNT	DESCRIPTION OF REVISIONS	
				DESIGNED	CHECKED
					DATE
APPROVED : WR. FUKUCHI			18.07.06	DRAWING NO. EDC-380574-51-00	
CHECKED : WR. FUKUCHI			18.07.06	PART NO. DF40TC(3.5)-30DS-0.4V(51)	
DESIGNED : SJ. WADA			18.07.06	CODE NO. CL684-4237-0-51	
DRAWN : RH. KAGAMI			18.07.06	1/2	

Jan.1.2022 Copyright 2022 HIROSE ELECTRIC CO., LTD. All Rights Reserved.
 In case of consideration for using Automotive equipment / device which demand high reliability, kindly contact our sales window correspondents.

EMBOSSED CARRIER TAPE PACKAGING (FREE)

STYLE AND DIMENSION OF REEL (FREE)

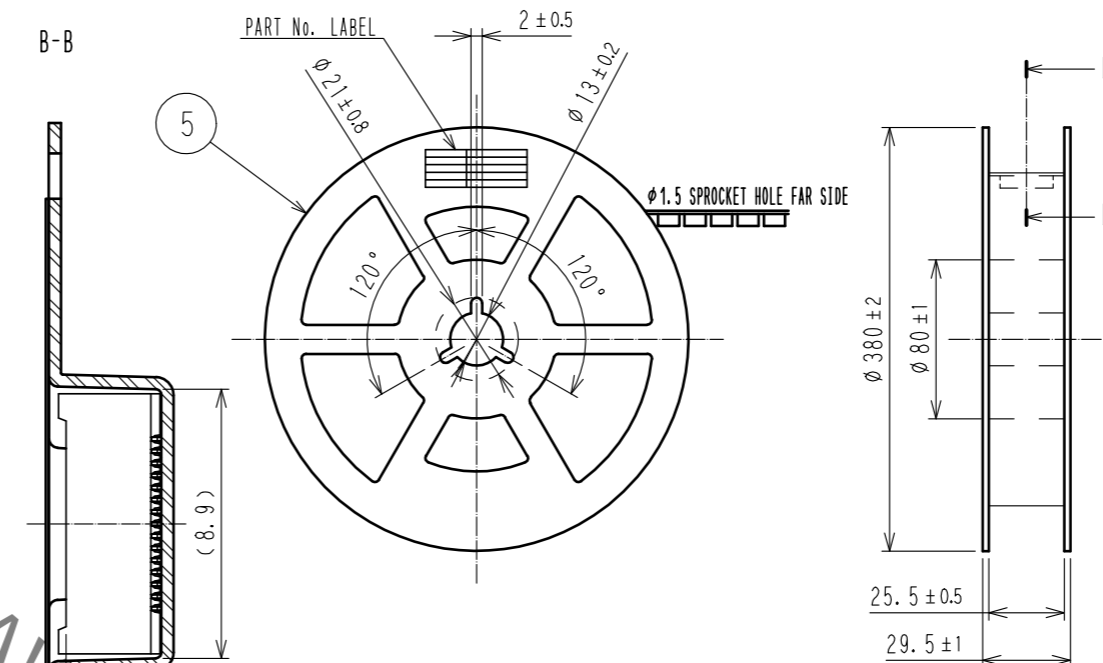
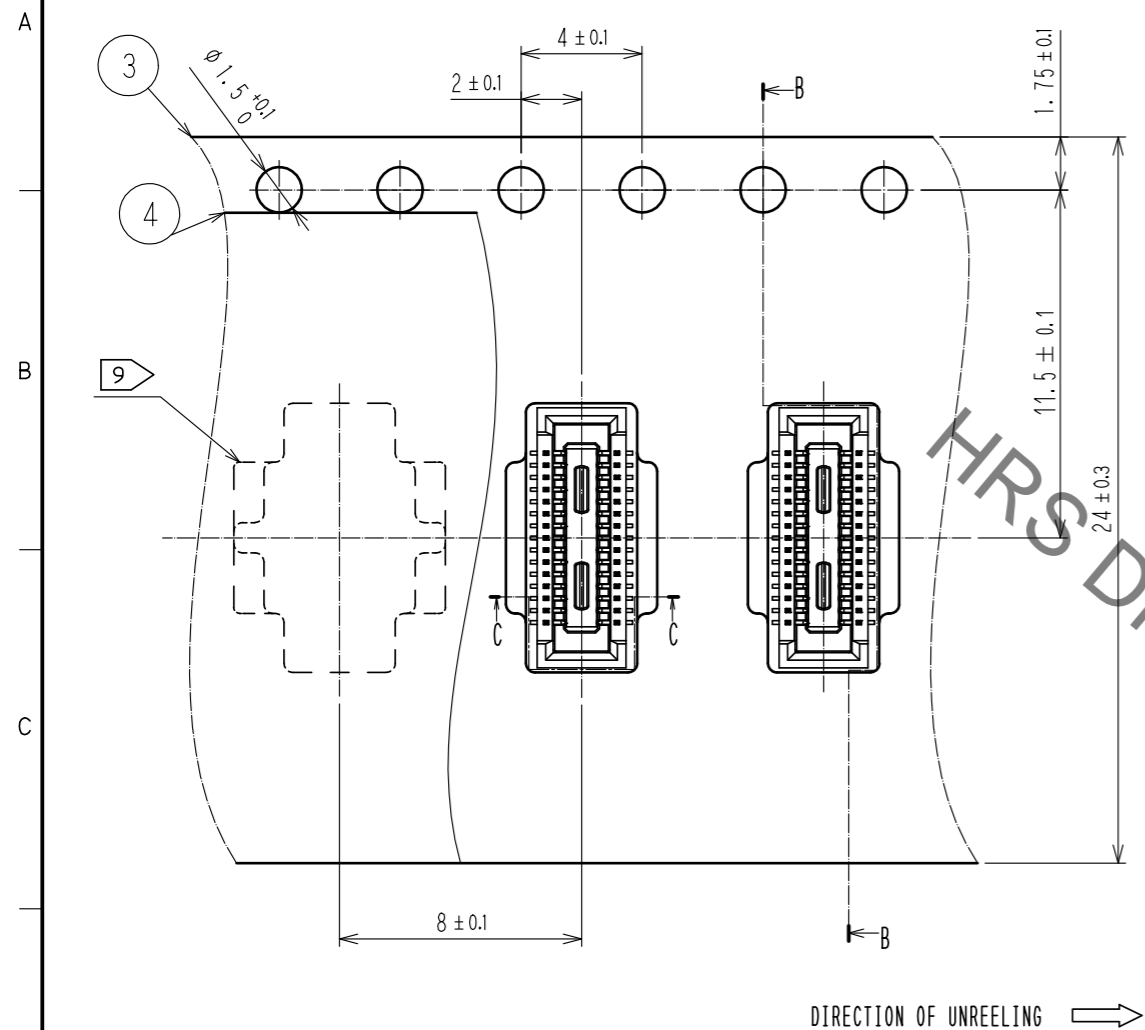

7 DETAIL OF PART No. LABEL

製造年月日	** ** *
製品コード	CL684-4237-0-51
製品名	DF40TC(3.5)-30DS-0.4V(51)
数量	2000
納入者	ヒロセ電機(株)

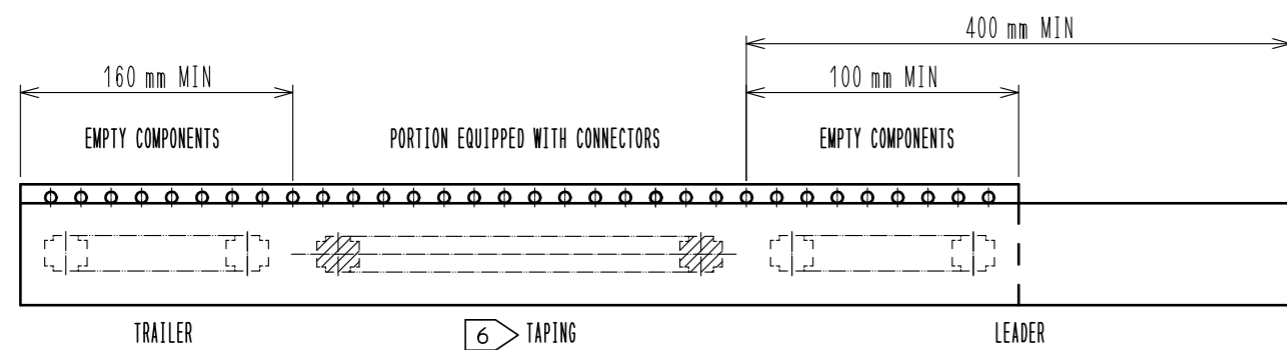
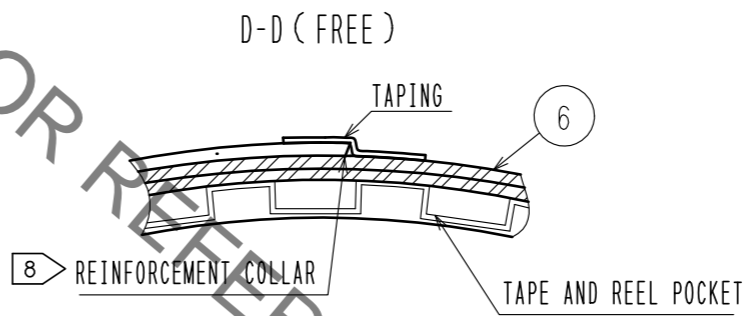
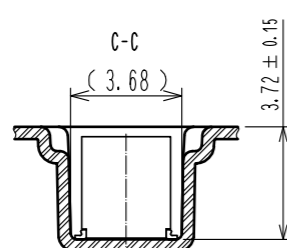

- NOTES
4. PER REEL 2000 CONNECTORS.
 5. THE DIMENSIONS IN PARENTHESES ARE FOR REFERENCE.
 6. REFER TO JIS C 0806(IEC 60286-3)(PACKING OF COMPONENTS FOR AUTOMATIC HANDLING)
 7. DETAIL OF PART NO. LABEL IS WRITTEN IN JAPANESE. PART NO. LABEL DESCRIBES THE FOLLOWING INFORMATION FROM TOP.
 PRODUCTION DATE:
 PRODUCT CODE: CL684-4237-0-51
 PART NUMBER: DF40TC(3.5)-30DS-0.4V(51)
 NUMBER OF PIECES: 2000 PIECES
 SUPPLIER NAME: HIROSE ELECTRIC CO., LTD.
 8. AFTER PACKAGING, ROLL 2 METERS OF THE REINFORCEMENT COLLAR TO OUTER CIRCUMFERENCE OF TAPE AND REEL POCKET, AND TAPE DOWN AT THE END THE COLLAR.
 9. ONE OF SEVERAL IS DIFFERENT IN FROM OF THE EMBOSSED CARRIER TAPE TO AVOID BEING STUCK IN.

HRS	DRAWING NO.	EDC-380574-51-00
	PART NO.	DF40TC(3.5)-30DS-0.4V(51)
	CODE NO.	CL684-4237-0-51

Mouser Electronics

Authorized Distributor

Click to View Pricing, Inventory, Delivery & Lifecycle Information:

[Hirose Electric:](#)

[DF40TC\(3.5\)-30DS-0.4V\(51\)](#)