

EC20 Mini PCIe

Hardware Design

LTE Module Series

Rev. EC20_Mini_PCl_e_Hardware_Design_V1.0

Date: 2015-02-28



Our aim is to provide customers with timely and comprehensive service. For any assistance, please contact our company headquarters:

Quectel Wireless Solutions Co., Ltd.

Office 501, Building 13, No.99, Tianzhou Road, Shanghai, China, 200233

Tel: +86 21 5108 6236

Mail: info@quectel.com

Or our local office, for more information, please visit:

<http://www.quectel.com/support/salesupport.aspx>

For technical support, to report documentation errors, please visit:

<http://www.quectel.com/support/techsupport.aspx>

Or Email: Support@quectel.com

GENERAL NOTES

QUECTEL OFFERS THIS INFORMATION AS A SERVICE TO ITS CUSTOMERS. THE INFORMATION PROVIDED IS BASED UPON CUSTOMERS' REQUIREMENTS. QUECTEL MAKES EVERY EFFORT TO ENSURE THE QUALITY OF THE INFORMATION IT MAKES AVAILABLE. QUECTEL DOES NOT MAKE ANY WARRANTY AS TO THE INFORMATION CONTAINED HEREIN, AND DOES NOT ACCEPT ANY LIABILITY FOR ANY INJURY, LOSS OR DAMAGE OF ANY KIND INCURRED BY USE OF OR RELIANCE UPON THE INFORMATION. THE INFORMATION SUPPLIED HEREIN IS SUBJECT TO CHANGE WITHOUT PRIOR NOTICE.

COPYRIGHT

THIS INFORMATION CONTAINED HERE IS PROPRIETARY TECHNICAL INFORMATION OF QUECTEL CO., LTD. TRANSMITTABLE, REPRODUCTION, DISSEMINATION AND EDITING OF THIS DOCUMENT AS WELL AS UTILIZATION OF THIS CONTENTS ARE FORBIDDEN WITHOUT PERMISSION. OFFENDERS WILL BE HELD LIABLE FOR PAYMENT OF DAMAGES. ALL RIGHTS ARE RESERVED IN THE EVENT OF A PATENT GRANT OR REGISTRATION OF A UTILITY MODEL OR DESIGN.

Copyright © Quectel Wireless Solutions Co., Ltd. 2015. All rights reserved.

About the Document

History

Revision	Date	Author	Description
1.0	2015-02-28	Radom XIANG/ Mike ZHANG	Initial

Quectel
Confidential

Contents

About the Document	2
Contents	3
Table Index	5
Figure Index	6
1 Introduction	7
1.1. Safety Information.....	8
2 Product Concept	9
2.1. General Description.....	9
2.2. Description of Product Series.....	9
2.3. Key Features.....	10
2.4. Functional Diagram.....	12
3 Application Interface	13
3.1. General Description.....	13
3.2. EC20 Mini PCIe Interface.....	13
3.2.1. Definition of Interface.....	13
3.2.2. Pin Assignment.....	16
3.3. Power Supply.....	17
3.4. USIM Card Interface.....	18
3.5. USB Interface.....	19
3.6. UART Interface.....	20
3.7. PCM and I2C Interface.....	22
3.8. Control Signals.....	24
3.8.1. RI Signal.....	25
3.8.2. DTR Signal.....	25
3.8.3. W_DISABLE# Signal.....	25
3.8.4. PERST# Signal.....	26
3.8.5. LED_WWAN# Signal.....	26
3.9. Antenna Interface.....	27
4 Electrical and Radio Characteristics	28
4.1. General Description.....	28
4.2. Power Supply Requirements.....	28
4.3. IO Requirements.....	29
4.4. RF Characteristics.....	29
4.5. GNSS Receiver.....	30
4.6. ESD Characteristics.....	31
5 Mechanical Dimensions	32
5.1. General Description.....	32
5.2. Mechanical Dimensions of EC20 Mini PCIe.....	32
5.3. Standard Dimensions of Mini PCI Express.....	33

5.4. Packaging 34

6 Appendix Reference 35

Quectel
Confidential

Table Index

TABLE 1: DESCRIPTION OF EC20 MINI PCIE.....	10
TABLE 2: KEY FEATURES OF EC20 MINI PCIE	10
TABLE 3: DEFINITION OF IO PARAMETERS.....	13
TABLE 4: DESCRIPTION OF PIN	14
TABLE 5: VCC_3V3 AND GND PIN DEFINITION	17
TABLE 6: USIM PIN DEFINITION	18
TABLE 7: USB PIN DEFINITION.....	19
TABLE 8: PIN DEFINITION OF THE UART INTERFACE.....	20
TABLE 9: PCM AND I2C PIN DEFINITION	22
TABLE 10: CONTROL SIGNAL PIN DEFINITION	24
TABLE 11: RADIO OPERATIONAL STATES.....	25
TABLE 12: INDICATION OF NETWORK STATUS.....	26
TABLE 13: POWER SUPPLY REQUIREMENTS.....	28
TABLE 14: IO REQUIREMENTS.....	29
TABLE 15: OUTPUT POWER OF CONDUCTED RF	29
TABLE 16: CONDUCTED RF RECEIVING SENSITIVITY.....	30
TABLE 17: ESD CHARACTERISTICS	31
TABLE 18: RELATED DOCUMENTS.....	35
TABLE 19: TERMS AND ABBREVIATIONS	35

Figure Index

FIGURE 1: FUNCTIONAL DIAGRAM	12
FIGURE 2: PIN ASSIGNMENT	16
FIGURE 3: REFERENCE DESIGN OF POWER SUPPLY	17
FIGURE 4: REFERENCE CIRCUIT OF THE 6-PIN USIM CARD	18
FIGURE 5: REFERENCE CIRCUIT OF USB INTERFACE	19
FIGURE 6: THE DCE-DTE CONNECTION OF UART INTERFACE	21
FIGURE 7: RS232 LEVEL MATCH CIRCUIT.....	21
FIGURE 8: TIMING OF PRIMARY MODE	23
FIGURE 9: TIMING OF AUXILIARY MODE	23
FIGURE 10: REFERENCE CIRCUIT OF PCM APPLICATION WITH AUDIO CODEC	24
FIGURE 11: RI BEHAVIOR	25
FIGURE 12: TIMING OF RESETTING MODULE	26
FIGURE 13: LED_WWAN# SIGNAL REFERENCE CIRCUIT DIAGRAM	26
FIGURE 14: DIMENSIONS OF THE RF CONNECTOR (UNIT: MM)	27
FIGURE 15: MECHANICALS OF U.F.L-LP CONNECTORS	27
FIGURE 16: MECHANICAL DIMENSIONS OF EC20 MINI PCIE (UNIT: MM).....	32
FIGURE 17: STANDARD DIMENSIONS OF MINI PCI EXPRESS (UNIT: MM)	33
FIGURE 18: DIMENSIONS OF THE MINI PCI EXPRESS CONNECTOR (UNIT: MM)	34

1 Introduction

This document defines EC20 Mini PCIe module and describes its hardware interfaces which are connected with your application and air interfaces.

This document can help you to quickly understand the interface specifications, electrical and mechanical details and related product information of the EC20 Mini PCIe module. To facilitate its application in different fields, relevant reference design documents are also provided. Associated with application notes and user guide of EC20 Mini PCIe module, you can use the module to design and set up mobile applications easily.

Quectel
Confidential

1.1. Safety Information

The following safety precautions must be observed during all phases of the operation, such as usage, service or repair of any cellular terminal or mobile incorporating EC20 Mini PCIe module. Manufacturers of the cellular terminal should send the following safety information to users and operating personnel and to incorporate these guidelines into all manuals supplied with the product. If not so, Quectel does not take on any liability for customer failure to comply with these precautions.



Full attention must be given to driving at all times in order to reduce the risk of an accident. Using a mobile while driving (even with a handsfree kit) cause distraction and can lead to an accident. You must comply with laws and regulations restricting the use of wireless devices while driving.



Switch off the cellular terminal or mobile before boarding an aircraft. Make sure it switched off. The operation of wireless appliances in an aircraft is forbidden to prevent interference with communication systems. Consult the airline staff about the use of wireless devices on boarding the aircraft, if your device offers a Airplane Mode which must be enabled prior to boarding an aircraft.



Switch off your wireless device when in hospitals or clinics or other health care facilities. These requests are desinged to prevent possible interference with sensitive medical equipment.



Cellular terminals or mobiles operate over radio frequency signal and cellular network and cannot be guaranteed to connect in all conditions, for example no mobile fee or an invalid SIM card. While you are in this condition and need emergent help, please remember using emergency call. In order to make or receive call, the cellular terminal or mobile must be switched on and in a service area with adequate cellular signal strength.



Your cellular terminal or mobile contains a transmitter and receiver. When it is ON, it receives and transmits radio frequency energy. RF interference can occur if it is used close to TV set, radio, computer or other electric equipment.



In locations with potentially explosive atmospheres, obey all posted signs to turn off wireless devices such as your phone or other cellular terminals. Areas with potentially exposable atmospheres including fuelling areas, below decks on boats, fuel or chemical transfer or storage facilities, areas where the air contains chemicals or particles such as grain, dust or metal powders.

2 Product Concept

2.1. General Description

EC20 Mini PCIe module provides data connectivity on FDD-LTE, WCDMA and GSM networks with PCI Express Mini Card 1.2 standard interface. It supports embedded operating system such as WinCE, Linux and Android etc., and also provides audio, high-speed data transmission and GPS/GLONASS functionality for your applications.

EC20 Mini PCIe module can be applied in the following fields:

- PDAs and Laptop Computer
- Remote Monitor System
- Vehicle System
- Wireless POS System
- Intelligent Meter Reading System
- Wireless Router and Switch
- Other Wireless Terminal Device

This chapter generally introduces the following aspects of EC20 Mini PCIe module:

- Product Series
- Key Features
- Functional Diagram

NOTE

EC20 Mini PCIe contains **Telematics** version and **Data-Only** version. **Telematics** version supports voice and data, while **Data-Only** version only supports data.

2.2. Description of Product Series

The following table shows the product series of EC20 Mini PCIe module.

Table 1: Description of EC20 Mini PCIe

Product Series	Description
EC20-E Mini PCIe	Support GSM: 850/900/1800/1900MHz Support UMTS: B1/B5/B8 Support LTE FDD: B1/B3/B5/B7/B8/B20 Support LTE/UMTS receive diversity Support GPS/GLONASS ¹⁾ Support digital audio ²⁾
EC20-A Mini PCIe	Support GSM: 850/1900MHz Support UMTS: B2/B4/B5 Support LTE FDD: B2/B4/B5/B12/B17 Support LTE/UMTS receive diversity Support GPS/GLONASS ¹⁾ Support digital audio ²⁾

NOTES

- ¹⁾ GPS/GLONASS function is optional.
- ²⁾ Digital audio (PCM) function is only supported in **Telematics** version.

2.3. Key Features

The following table describes the detailed features of EC20 Mini PCIe module.

Table 2: Key Features of EC20 Mini PCIe

Feature	Details
Function Interface	PCI Express Mini Card 1.2 Standard Interface
Power Supply	Supply voltage: 3.0~3.6V Typical supply voltage: 3.3V
Transmitting Power	Class 4 (33dBm±2dB) for GSM850 and EGSM900 Class 1 (30dBm±2dB) for DCS1800 and PCS1900 Class E2 (27dBm±3dB) for GSM850 and EGSM900 8-PSK Class E2 (26dBm±3dB) for DCS1800 and PCS1900 8-PSK Class 3 (24dBm+1/-3dB) for UMTS B1/B2/B4/B5/B8 Class 3 (23dBm±2dB) for LTE FDD B1/B2/B3/B4/B5/B7/B8/B12/B17/B20
LTE Features	Support category3 FDD and corresponded with 3GPP R9 Support 1.4 to 20MHz RF bandwidth

	Support 2 × 2 MIMO in DL direction Max 100Mbps (DL), Max 50Mbps (UL)
WCDMA Features	R99 CS data: Max 64kbps (DL), Max 64kbps (UL) R99 PS data: Max 384kbps (DL), Max 384kbps (UL) R5 HSDPA: Max 7.2Mbps (DL) R6 HSUPA: Max 5.76Mbps (UL) R7 HSPA+: Max 21Mbps (DL), Max 5.76Mbps (UL) R8 DC-HSPA+: Max 42Mbps (DL)
GSM Features	R99: CS data: 9.6k, 14.4kbps GPRS: Support GPRS multi-slot class 12 Coding scheme: CS-1, CS-2, CS-3 and CS-4 Maximum of four Rx time slots per frame EDGE: Support EDGE multi-slot class 12 Support GMSK and 8-PSK for different MCS (Modulation and Coding Scheme) Downlink coding schemes: CS 1-4, MCS 1-9 Uplink coding schemes: CS 1-4, MCS 1-9
Internet Protocol Features	Support PPP protocols Support the protocols PAP (Password Authentication Protocol) and CHAP (Challenge Handshake Authentication Protocol) usually used for PPP connections
SMS	Text and PDU mode Point to point MO and MT SMS cell broadcast SMS storage: ME by default
USIM Interface	Support USIM/SIM card: 1.8V, 3.0V
UART Interface	Support two lines on UART interface Baud rate can reach up to 230400bps, 115200bps by default Used for AT command Support multiplexing function*
PCM Interface	Support 8-bit A-law*, μ -law* and 16-bit linear data formats Support long frame sync and short frame sync Support master and slave mode, but must be the master in long frame sync
USB Interface	Compliant with USB 2.0 specification (slave only), the data transfer rate can reach up to 480Mbps. Used for AT command communication, data transmission, firmware upgrade, software debug and GNSS NMEA output. USB Driver: Support Windows XP, Windows Vista, Windows 7, Windows 8/8.1, Linux 2.6 or later, Android 2.3/4.0/4.2/4.4.
Antenna Interface	Include main LTE/UMTS/GSM antenna, LTE/UMTS diversity antenna, GNSS antenna (passive)
GNSS Features	gpsOne Gen8A of Qualcomm (GPS and GLONASS)

	Protocol: NMEA 0183
Rx-diversity	Support LTE/UMTS Rx-diversity
AT Commands	Compliant with 3GPP TS 27.007, 27.005 and Quectel enhanced AT commands
Physical Characteristics	Size: 51.0mm × 30.0mm × 4.9mm Weight: approx. 9.8g
Temperature Range	Normal operation: -30°C ~ +70°C Restricted operation: -40°C ~ -30°C and +70°C ~ +80°C [▲] Storage temperature: -45°C ~ +90°C
Firmware Upgrade	USB interface
RoHS	All hardware components are fully compliant with EU RoHS directive

NOTES

1. “*” means this function is under development.
2. “▲” means when the module works within this temperature range, RF performance might degrade. For example, the frequency error or the phase error may increase.

2.4. Functional Diagram

The following figure shows a block diagram of EC20 Mini PCIe.

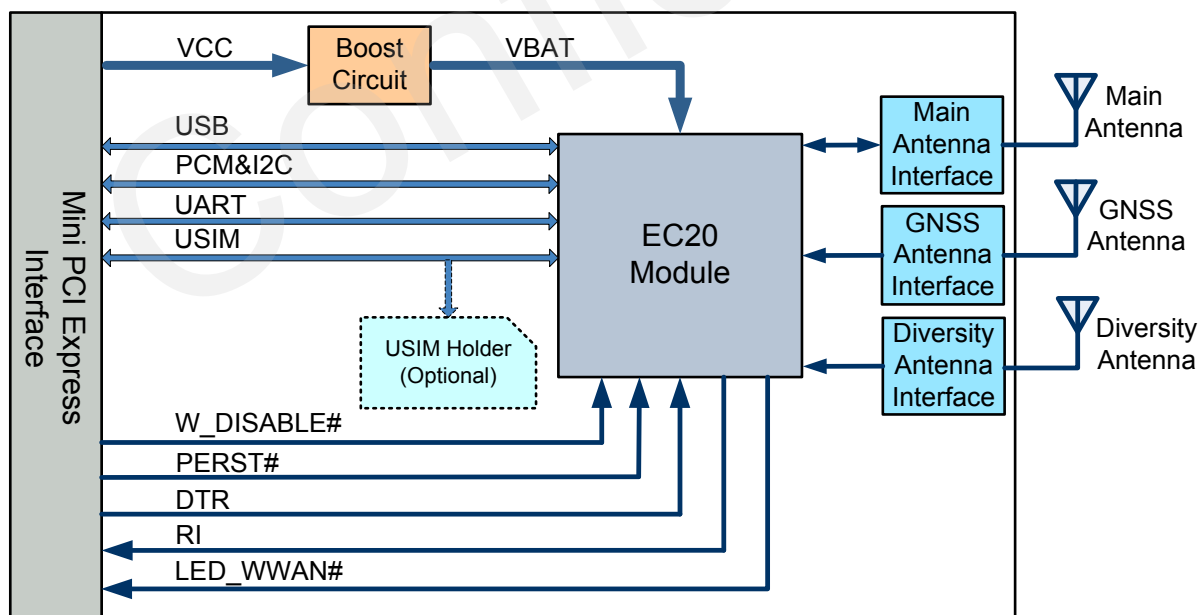

Figure 1: Functional Diagram

3 Application Interface

3.1. General Description

The physical connections and signal levels of EC20 Mini PCIe comply with PCI Express Mini CEM specifications. This chapter mainly describes the following interface definition and application of EC20 Mini PCIe:

- Power supply
- USIM interface
- USB interface
- UART interface
- PCM&I2C interface
- Control signals
- Antenna interface

3.2. EC20 Mini PCIe Interface

3.2.1. Definition of Interface

The following tables show the pin assignments of EC20 Mini PCIe on the 52-pin application.

Table 3: Definition of IO Parameters

Type	Description
IO	Bidirectional input/output
DI	Digital input
DO	Digital output
OC	Open collector
OD	Open drain
PI	Power input

PO Power output

Table 4: Description of Pin

Pin No.	Mini PCI Express Standard Name	EC20 Mini PCIe Pin Name	I/O	Description	Comment
1	WAKE#	RESERVED	—	Reserved	
2	3.3Vaux	VCC_3V3	PI	3.3V DC supply	
3	COEX1	RESERVED	—	Reserved	
4	GND	GND		Mini Card ground	
5	COEX2	RESERVED	—	Reserved	
6	1.5V	NC	—	—	
7	CLKREQ#	RESERVED	—	Reserved	
8	UIM_PWR	USIM_VDD	PO	Power source for the USIM/SIM card	
9	GND	GND		Mini Card ground	
10	UIM_DATA	USIM_DATA	IO	USIM/SIM data signal	
11	REFCLK-	UART_RX	DI	UART receive data	Connect to DTE's TX
12	UIM_CLK	USIM_CLK	DO	USIM/SIM clock signal	
13	REFCLK+	UART_TX	DO	UART transmit data	Connect to DTE's RX
14	UIM_RESET	USIM_RST	DO	USIM/SIM reset signal	
15	GND	GND		Mini Card ground	
16	UIM_VPP	RESERVED	—	Reserved	
17	RESERVED	RI	DO	URC ring indication	
18	GND	GND		Mini Card ground	
19	RESERVED	RESERVED	—	Reserved	
20	W_DISABLE#	W_DISABLE#	DI	Disable wireless communications	Pull-up, Active low
21	GND	GND		Mini Card ground	
22	PERST#	PERST#	DI	Functional reset to the card	Active low

23	PERn0	RESERVED	—	Reserved
24	3.3Vaux	RESERVED	—	Reserved
25	PERp0	RESERVED	—	Reserved
26	GND	GND		Mini Card ground
27	GND	GND		Mini Card ground
28	1.5V	NC	—	—
29	GND	GND		Mini Card ground
30	SMB_CLK	I2C_SCL	OD	I2C serial clock
31	PETn0	DTR	DI	Sleep mode control
32	SMB_DATA	I2C_SDA	OD	I2C serial data
33	PETp0	RESERVED	—	Reserved
34	GND	GND		Mini Card ground
35	GND	GND		Mini Card ground
36	USB_D-	USB_DM	IO	USB differential data (-)
37	GND	GND		Mini Card ground
38	USB_D+	USB_DP	IO	USB differential data (+)
39	3.3Vaux	VCC_3V3	PI	3.3V DC supply
40	GND	GND		Mini Card ground
41	3.3Vaux	VCC_3V3	PI	3.3V DC supply
42	LED_WWAN#	LED_WWAN#	OC	Active-low LED signal for indicating the state of the card
43	GND	GND		Mini Card ground
44	LED_WLAN#	RESERVED	—	Reserved
45	RESERVED	PCM_CLK*	IO	PCM clock signal
46	LED_WPAN#	RESERVED	—	Reserved
47	RESERVED	PCM_DOUT*	DO	PCM data output
48	1.5V	NC	—	—
49	RESERVED	PCM_DIN*	DI	PCM data input

50	GND	GND		Mini Card ground
51	RESERVED	PCM_SYNC*	IO	PCM frame sync
52	3.3Vaux	VCC_3V3	PI	3.3V DC supply

NOTES

1. The typical supply voltage is 3.3V.
2. Keep all NC, reserved and unused pins unconnected.
3. Pay attention to the height of Mini PCI Express connector located on DTE, and USIM pins 8, 10, 12 and 14 cannot be used at the same time when using the optional USIM holder.
4. "*" means digital audio (PCM) function is only supported on **Telematics** version.

3.2.2. Pin Assignment

The following figure shows the pin assignment of EC20 Mini PCIe module. The top side contains EC20 module and antenna connectors.

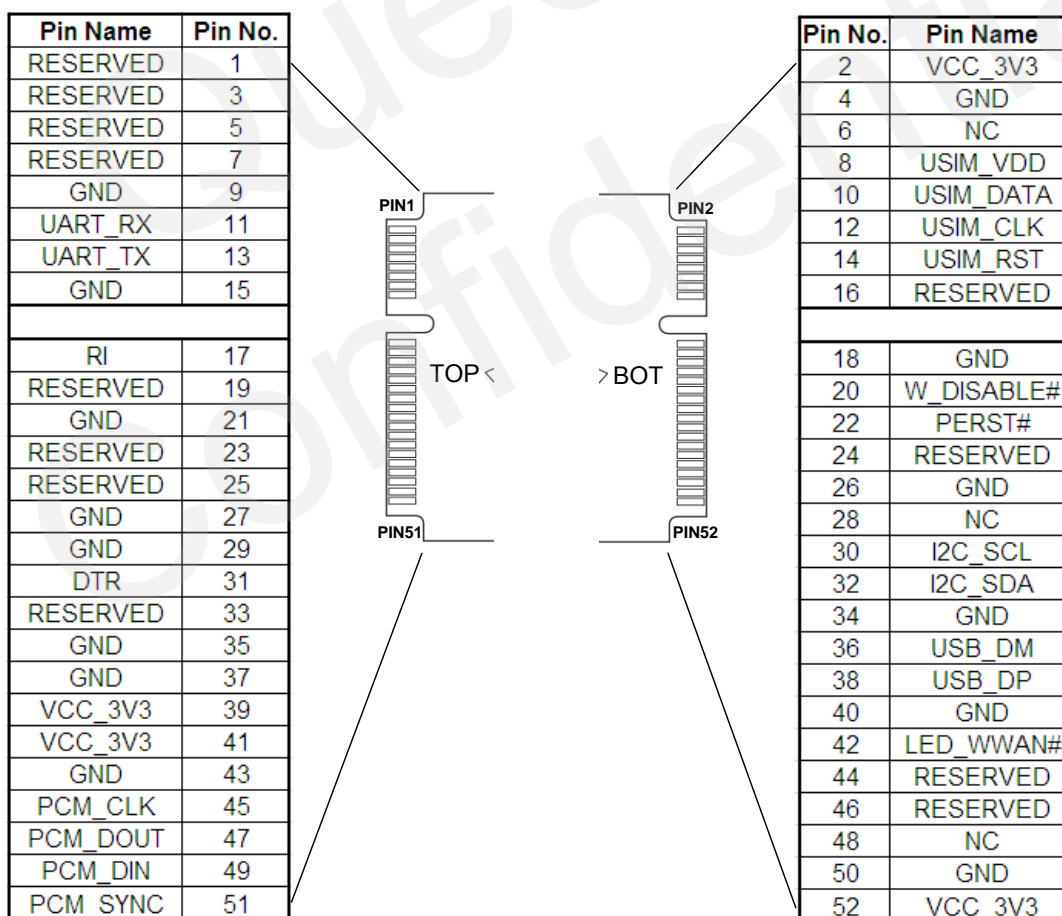

Figure 2: Pin Assignment

3.3. Power Supply

The following table shows the VCC_3V3 pins and ground pins.

Table 5: VCC_3V3 and GND Pin Definition

Pin No.	Pin Name	I/O	Power Domain	Description
2, 39, 41, 52	VCC_3V3	PI	3.0~3.6V	3.3V DC supply
4, 9, 15, 18, 21, 26, 27, 29, 34, 35, 37, 40, 43, 50	GND			Mini Card ground

The typical supply voltage of EC20 Mini PCIe is 3.3V. In the 2G networks, the input peak current may reach to 2.7A during the transmitting time, therefore the power supply must be able to provide enough current, and a bypass capacitor of no less than 470µF with low ESR should be used to prevent the voltage from dropping.

The following figure shows a reference design of power supply. The precision of resistor R2 and R3 is 1%, and the capacitor C3 needs a low ESR.

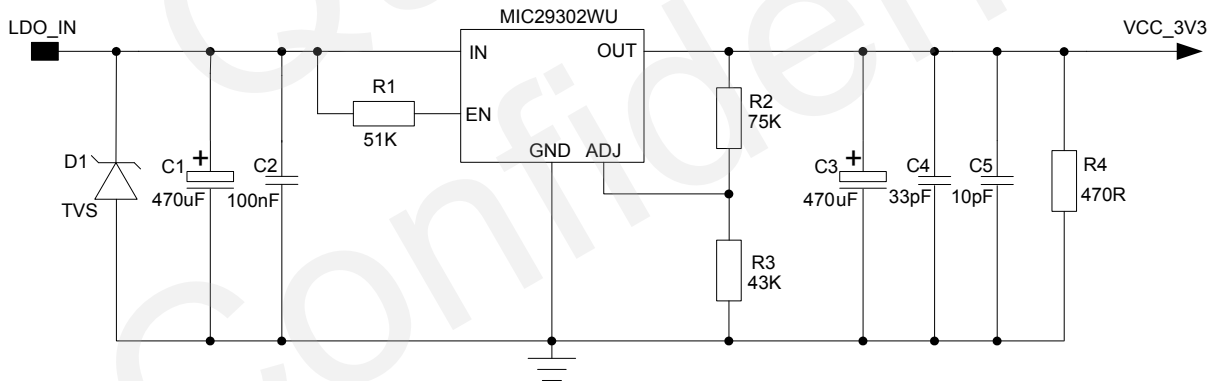

Figure 3: Reference Design of Power Supply

3.4. USIM Card Interface

The following table shows the pin definition of the USIM card interface.

Table 6: USIM Pin Definition

Pin No.	Pin Name	I/O	Power Domain	Description
8	USIM_VDD	PO	1.8V/3.0V	Power source for the USIM/SIM card
10	USIM_DATA	IO	1.8V/3.0V	USIM/SIM data signal
12	USIM_CLK	DO	1.8V/3.0V	USIM/SIM clock signal
14	USIM_RST	DO	1.8V/3.0V	USIM/SIM reset signal

EC20 Mini PCIe supports 1.8V and 3.0V USIM cards. The following figure shows the reference design of the 6-pin USIM card.

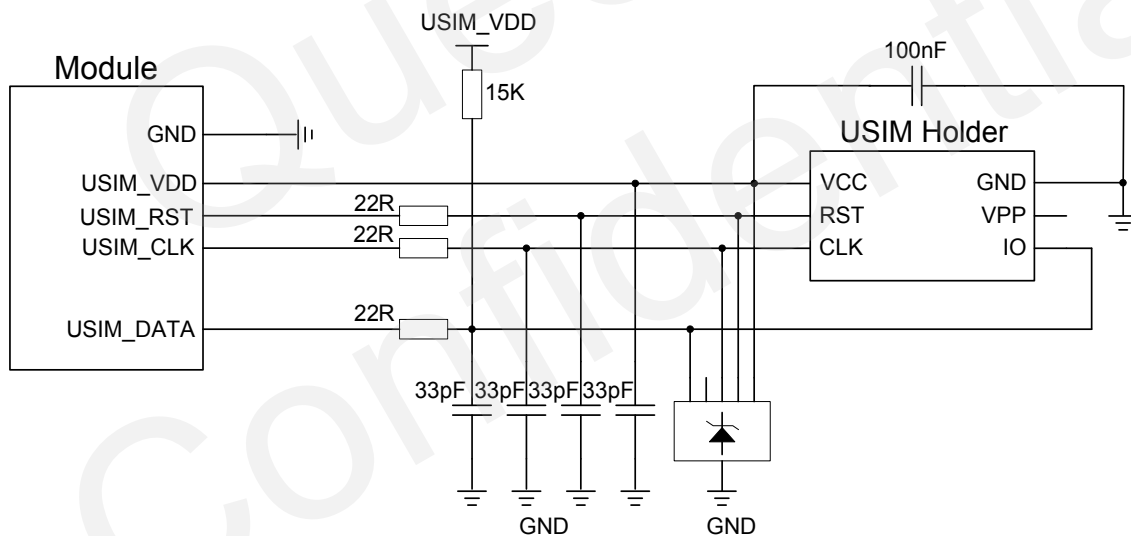

Figure 4: Reference Circuit of the 6-Pin USIM Card

In order to enhance the reliability and availability of the USIM card in your application, please follow the criteria below in the USIM circuit design:

- Keep layout of USIM card as close to the module as possible. Assure the length of the trace as less than 200mm as possible.
- Keep USIM card signal away from RF and power supply alignment.
- Keep the width of ground and USIM_VDD no less than 0.5mm to maintain the same electric potential. The decouple capacitor of USIM_VDD should be less than 1uF and must near to USIM holder.

- To avoid cross-talk between USIM_DATA and USIM_CLK, keep them away from each other and shield them with surrounding ground.
- In order to offer good ESD protection, it is recommended to add TVS. The 22R resistors should be added in series between the module and USIM card so as to suppress the EMI spurious transmission and enhance the ESD protection. The 33pF capacitors are used for filtering interference of GSM850/EGSM900. Please note that the USIM peripheral circuit should be close to the USIM card holder.
- The pull-up resistor on USIM_DATA line can improve anti-jamming capability when long layout trace and sensitive occasion are applied, and should be placed close to the holder.

3.5. USB Interface

The following table shows the pin definition of USB interface.

Table 7: USB Pin Definition

Pin No.	Pin Name	I/O	Description	Comment
36	USB_DM	IO	USB differential data (-)	Require differential impedance of 90Ω
38	USB_DP	IO	USB differential data (+)	Require differential impedance of 90Ω

EC20 Mini PCIe is compliant with USB 2.0 specification. It can only be used as a slave device. Meanwhile, it supports high speed (480Mbps) and full speed (12Mbps) mode. The USB interface is used for AT command, data transmission, GNSS NMEA output, software debug and firmware upgrade. The following figure shows the reference circuit of USB interface.

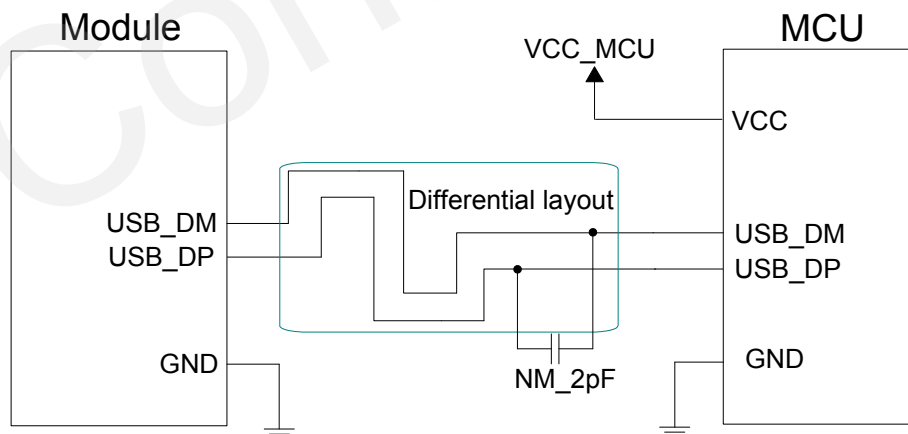

Figure 5: Reference Circuit of USB Interface

In order to ensure the USB interface design corresponding with the USB 2.0 specification, please comply with the following principles:

- It is important to route the USB signal traces as differential pairs with total grounding. The impedance of USB differential trace is 90ohm.
- Do not route signal traces under crystals, oscillators, magnetic devices and RF signal traces. It is important to route the USB differential traces in inner-layer with ground shielding, and not only upper and lower layer but also right and left side should be shielded.
- If you use the USB connector, you should keep the ESD components as close to the USB connector as possible. Pay attention to the influence of junction capacitance of ESD component on USB data lines. Typically, the capacitance value should be less than 2pF.

NOTES

There are three preconditions when enabling EC20 Mini PCIe to enter into the sleep mode:

1. Execute AT command **AT+QSCLK=1** to enable the sleep mode. Refer to **document [2]**.
2. DTR pin should be kept in high level (pull-up internally).
3. USB interface on Mini PCIe must be connected with your USB interface and please guarantee USB devices are in the suspended state.

3.6. UART Interface

The following table shows the pin definition of the UART interface.

Table 8: Pin Definition of the UART Interface

Pin No.	EC20 Mini PCIe Pin Name	I/O	Power Domain	Description
11	UART_RX	DI	3.3V	UART receive data
13	UART_TX	DO	3.3V	UART transmit data

The UART interface supports 9600, 19200, 38400, 57600, 115200 and 230400bps baud rate. The default is 115200bps. This interface can be used for AT communication.

EC20 Mini PCIe is designed as the DCE, and the DCE-DTE connection of UART interface is shown as below.

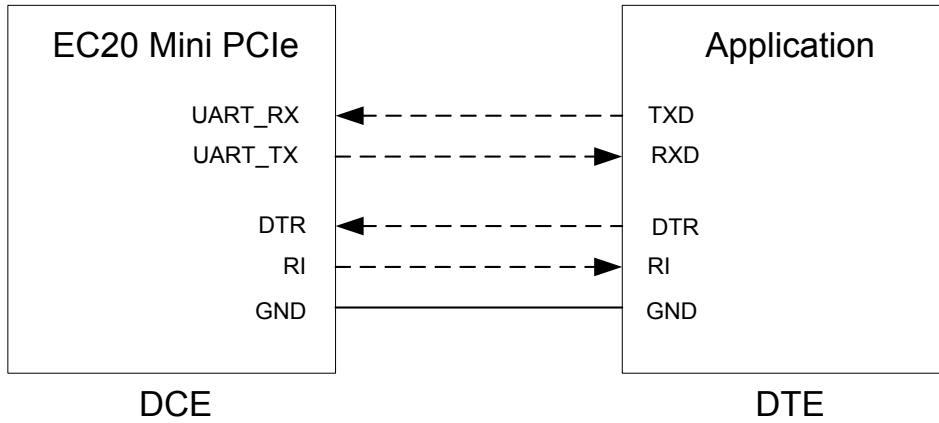

Figure 6: The DCE-DTE Connection of UART Interface

The following figure is an example of connection between EC20 Mini PCIe and PC. Since the UART interface does not support the RS-232 level, A RS-232 level translator IC must be inserted between module and PC. A RS-232 level shifter SN65C3238 provided by **Texas Instruments** is recommended. The following figure shows the reference design of RS232 level match circuit.

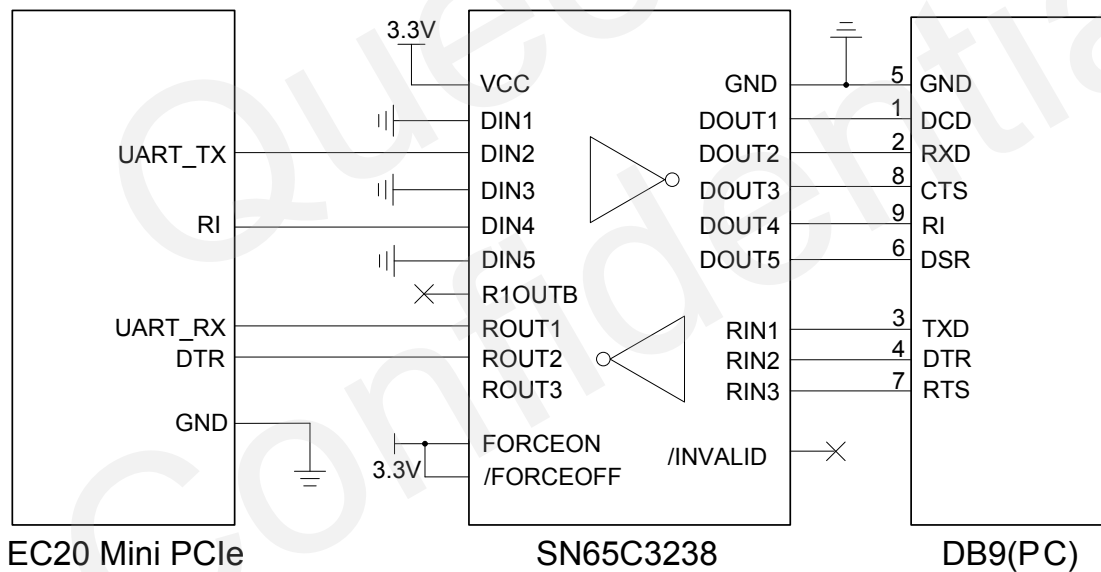

Figure 7: RS232 Level Match Circuit

NOTE

AT command **AT+IPR** is used to set the baud rate of the UART. Please refer to **document [2]** for details.

3.7. PCM and I2C Interface

The following table shows the pin definition of PCM interface that can be applied in audio codec design.

Table 9: PCM and I2C Pin Definition

Pin No.	Pin Name	I/O	Power Domain	Description
45	PCM_CLK	IO	1.8V	PCM clock signal
47	PCM_DOUT	DO	1.8V	PCM data output
49	PCM_DIN	DI	1.8V	PCM data input
51	PCM_SYNC	IO	1.8V	PCM frame sync
30	I2C_SCL	OD	1.8V	I2C serial clock, require external pull-up to 1.8V
32	I2C_SDA	OD	1.8V	I2C serial data, require external pull-up to 1.8V

EC20 Mini PCIe provides one PCM digital interface, which supports 8-bit A-law and μ -law, 16-bit linear data formats and the following modes:

- Primary mode (short sync, works as either master or slave)
- Auxiliary mode (long sync, works as master only)

In primary mode, the data is sampled on the falling edge of the PCM_CLK and transmitted on the rising edge; the PCM_SYNC falling edge represents the MSB. In this mode, PCM_CLK supports 128kHz, 256kHz, 512kHz, 1024kHz, 2048kHz and 4096kHz. The following figure shows timing relationship in primary mode with 8kHz PCM_SYNC and 2048kHz PCM_CLK.

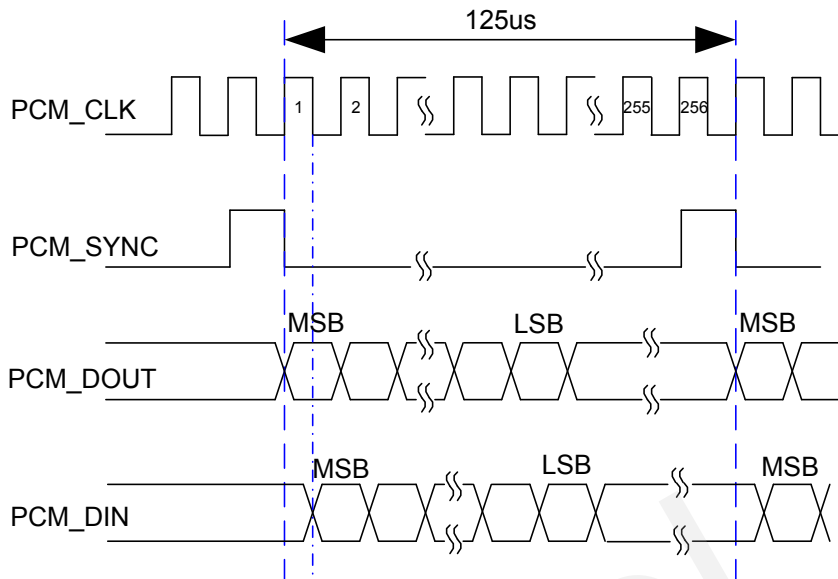

Figure 8: Timing of Primary Mode

In auxiliary mode, the data is sampled on the falling edge of the PCM_CLK and transmitted on the rising edge; while the PCM_SYNC rising edge represents the MSB. In this mode, PCM interface operates with a 128kHz PCM_CLK and an 8kHz, 50% duty cycle PCM_SYNC only. The following figure shows the timing relationship in auxiliary mode with 8kHz PCM_SYNC and 128kHz PCM_CLK.

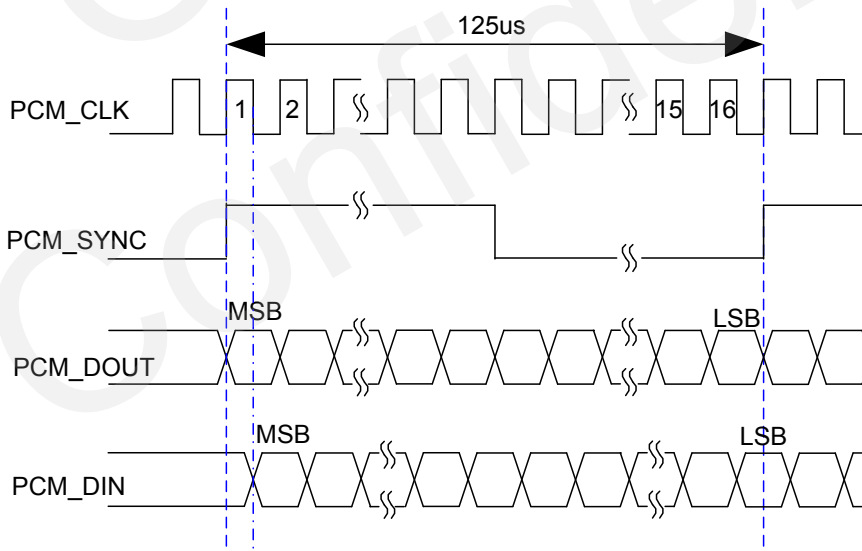

Figure 9: Timing of Auxiliary Mode

Clock and mode can be configured by AT command, and the default configuration is master mode using short sync data format with 2048kHz PCM_CLK and 8kHz PCM_SYNC.

The following figure shows the reference design of PCM interface with external codec IC (such as ALC5616).

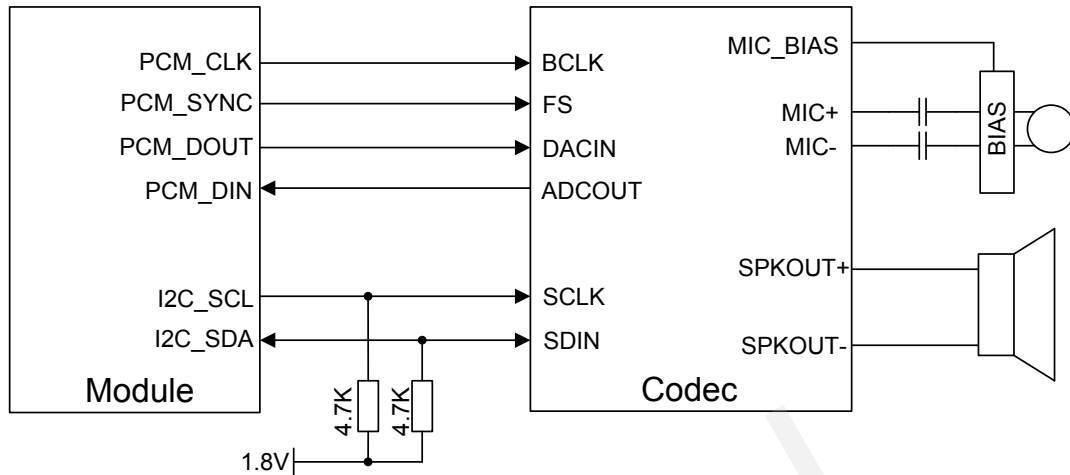

Figure 10: Reference Circuit of PCM Application with Audio Codec

3.8. Control Signals

The following table shows the pin definition of control signals.

Table 10: Control Signal Pin Definition

Pin No.	Pin Name	I/O	Power Domain	Description
17	RI	DO	3.3V	URC ring indication, can be used to wake up the host
31	DTR	DI	3.3V	Sleep mode control
20	W_DISABLE#	DI	3.3V	Disable wireless communications Pull-up by default. Active low
22	PERST#	DI	3.3V	Functional reset to the card Active low
42	LED_WWAN#	OC	—	Active-low LED signal for indicating the state of the Module

3.8.1. RI Signal

The RI signal can be used to wake up the host. When URC returns, there will be the following behavior on the RI pin.

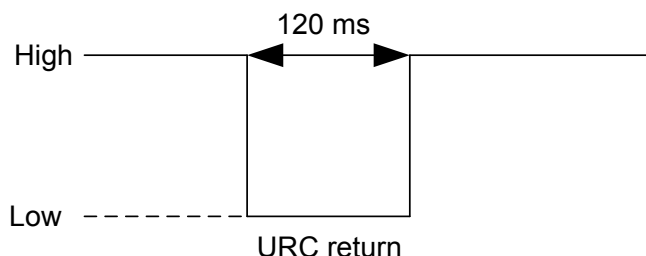

Figure 11: RI Behavior

3.8.2. DTR Signal

The DTR signal supports sleep control function, drive it to low level will wake up the module. AT command **AT+QCFG="pwrsavedtr"** is used to disable the sleep control function.

3.8.3. W_DISABLE# Signal

EC20 Mini PCIe provides W_DISABLE# signal to disable wireless communications through hardware operation. The following table shows the radio operational states of module. Please refer to **document [2]** for related AT commands.

Table 11: Radio Operational States

W_DISABLE#	AT Commands	Radio Operation
High Level	AT+CFUN=1	Enabled
High Level	AT+CFUN=0 AT+CFUN=4	Disabled
Low Level	AT+CFUN=0 AT+CFUN=1 AT+CFUN=4	Disabled

3.8.4. PERST# Signal

The PERST# signal can be used to force a hardware reset on the card. You can reset the module by driving the PERST# to a low level voltage of more than 150ms and then release it. The reset scenario is illustrated in the following figure.

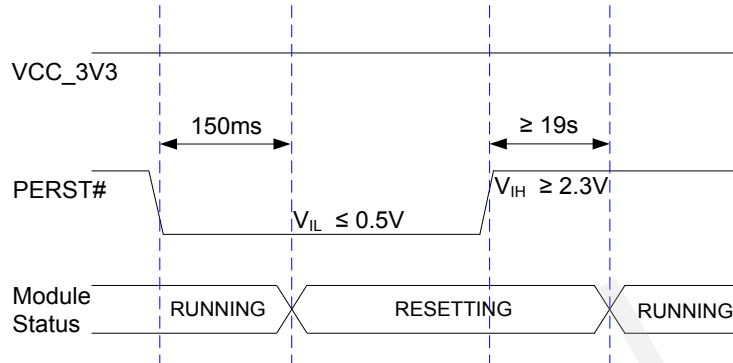

Figure 12: Timing of Resetting Module

3.8.5. LED_WWAN# Signal

The LED_WWAN# signal of EC20 Mini PCIe is used to indicate the network status of the module, which can absorb the current up to 40mA. According to the following circuit, in order to reduce the current of the LED, a resistor must be placed in series with the LED. The LED is emitting light when the LED_WWAN# output signal is active low.

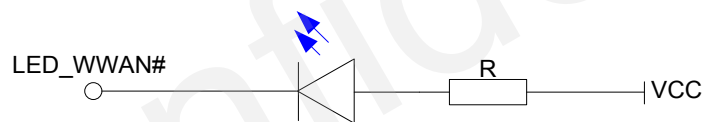

Figure 13: LED_WWAN# Signal Reference Circuit Diagram

The following table shows the indications of network status of the LED_WWAN# signal.

Table 12: Indication of Network Status

LED_WWAN#	Description
Low Level (Light on)	Registered network
High-impedance (Light off)	<ul style="list-style-type: none"> ● No network coverage or not registered ● W_DISABLE# signal is in low level. (Disable the RF) ● AT+CFUN=0, AT+CFUN=4

3.9. Antenna Interface

EC20 Mini PCIe antenna interfaces include a main LTE/UMTS/GSM antenna interface, a LTE/UMTS Rx-diversity antenna interface and a GNSS antenna interface. All of these connectors are ECT818000117. The following figure shows the overall sizes of RF connector.

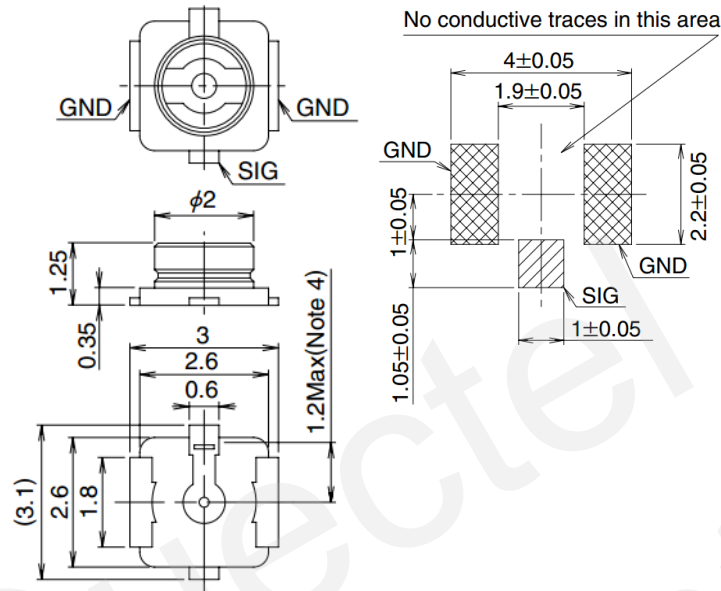

Figure 14: Dimensions of the RF Connector (Unit: mm)

You can use U.FL-LP serial connector listed in the following figure to match the ECT818000117. For more details, please visit <http://www.hirose.com>.

	U.FL-LP-040	U.FL-LP-066	U.FL-LP(V)-040	U.FL-LP-062	U.FL-LP-088
Part No.					
Mated Height	2.5mm Max. (2.4mm Nom.)	2.5mm Max. (2.4mm Nom.)	2.0mm Max. (1.9mm Nom.)	2.4mm Max. (2.3mm Nom.)	2.4mm Max. (2.3mm Nom.)
Applicable cable	Dia. 0.81mm Coaxial cable	Dia. 1.13mm and Dia. 1.32mm Coaxial cable	Dia. 0.81mm Coaxial cable	Dia. 1mm Coaxial cable	Dia. 1.37mm Coaxial cable
Weight (mg)	53.7	59.1	34.8	45.5	71.7
RoHS	YES				

Figure 15: Mechanicals of UF.L-LP Connectors

4 Electrical and Radio Characteristics

4.1. General Description

This chapter mainly describes the following electrical and radio characteristics of EC20 Mini PCIe:

- Power supply requirements
- IO requirements
- Current consumption
- RF characteristics
- GNSS receiver
- ESD characteristics

4.2. Power Supply Requirements

The input voltage of EC20 Mini PCIe is $3.3V \pm 9\%$, as specified by PCI Express Mini CEM Specifications 1.2. The following table shows the power supply requirements of EC20 Mini PCIe.

Table 13: Power Supply Requirements

Parameter	Description	Min.	Typ.	Max.	Unit
VCC_3V3	Power Supply	3.0	3.3	3.6	V

4.3. IO Requirements

The following table shows the IO requirements of EC20 Mini PCIe.

Table 14: IO Requirements

Parameter	Description	Min.	Max.	Unit
V _{IH}	Input High Voltage	0.7*VDDIO	VDDIO+0.3	V
V _{IL}	Input Low Voltage	-0.3	0.3*VDDIO	V
V _{OH}	Output High Voltage	VDDIO-0.5	VDDIO	V
V _{OL}	Output Low Voltage	0	0.4	V

NOTES

1. The PCM and I2C interface belong to 1.8V power domain, and other IO interfaces belong to 3.3V power domain.
2. The maximum value of V_{IL} for PERST# signal and W_DISABLE# signal is 0.5V.

4.4. RF Characteristics

The following tables show output power and receiving sensitivity of conducted RF of EC20 Mini PCIe module.

Table 15: Output Power of Conducted RF

Frequency	Max.	Min.
GSM850/EGSM900	33dBm±2dB	5dBm±5dB
DCS1800/PCS1900	30dBm±2dB	0dBm±5dB
GSM850/EGSM900(8-PSK)	27dBm±3dB	5dBm±5dB
DCS1800/PCS1900(8-PSK)	26dBm±3dB	0dBm±5dB
UMTS B1/B2/B4/B5/B8	24dBm+1/-3dB	<-50dBm
LTE B1/B2/B3/B4/B5/B7/B8/B12/B17/B20	23dBm±2dB	<-44dBm

Table 16: Conducted RF Receiving Sensitivity

Frequency	Receive Sensitivity (Typ.)
GSM850	-111dBm
EGSM900	-110dBm
DCS1800	-109dBm
PCS1900	-109dBm
UMTS B1	-110dBm
UMTS B5	-112dBm
UMTS B8	-111dBm
LTE FDD B1 (20M)	-97dBm
LTE FDD B3 (20M)	-96dBm
LTE FDD B5 (10M)	-99dBm
LTE FDD B7 (20M)	-97dBm
LTE FDD B8 (10M)	-98dBm
LTE FDD B20 (20M)	-96dBm

4.5. GNSS Receiver

EC20 Mini PCIe integrates a GNSS receiver that supports gpsOne Gen8A of Qualcomm (GPS and GLONASS), and could be used in Qualcomm gpsOneXTRA technology (one kind of A-GNSS). This technology will download XTRA file from the internet server to enhance the TTFF. XTRA file contains predicted GPS and GLONASS satellites coordinates and clock biases valid for up to 7 days. It is best if XTRA file is downloaded every 1-2 days. Additionally, EC20 Mini PCIe can support standard NMEA-0183 protocol and output NMEA messages with 1Hz via USB NMEA interface.

EC20 Mini PCIe GNSS engine is switched off by default. You must switch on it by AT command. Please refer to **document [3]** for more details about GNSS engine technology and configurations. In addition, it should use passive antenna.

4.6. ESD Characteristics

The following table shows characteristics of EC20 Mini PCIe ESD.

Table 17: ESD Characteristics

Part	Contact Discharge	Air Discharge	Unit
Power Supply and GND	+/-5	+/-10	kV
Antenna Interface	+/-4	+/-8	kV
USB Interface	+/-4	+/-8	kV
USIM Interface	+/-4	+/-8	kV
Others	+/-0.5	+/-1	kV

Quectel
Confidential

5 Mechanical Dimensions

5.1. General Description

This chapter mainly describes the following dimensions of EC20 Mini PCIe:

- Mechanical Dimensions of EC20 Mini PCIe
- Standard Dimensions of Mini PCI Express
- Packaging

5.2. Mechanical Dimensions of EC20 Mini PCIe

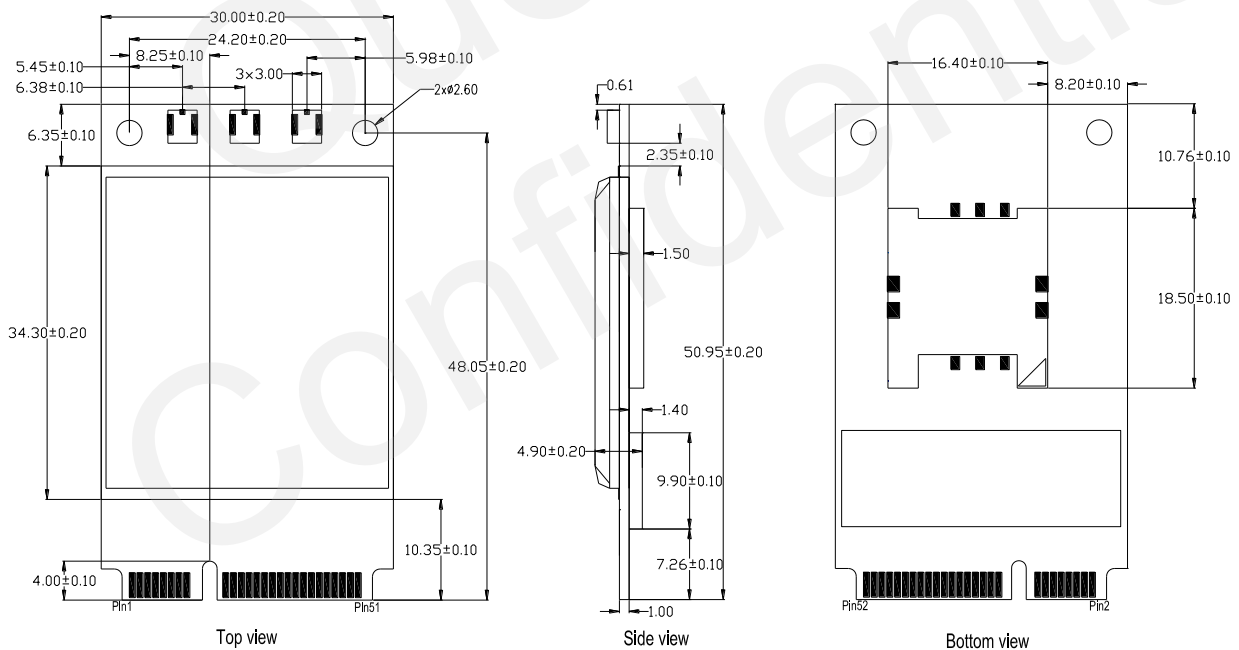

Figure 16: Mechanical Dimensions of EC20 Mini PCIe (Unit: mm)

5.3. Standard Dimensions of Mini PCI Express

The following figure shows the standard Dimensions of Mini PCI Express. Please refer to **document [1]** for detailed A and B.

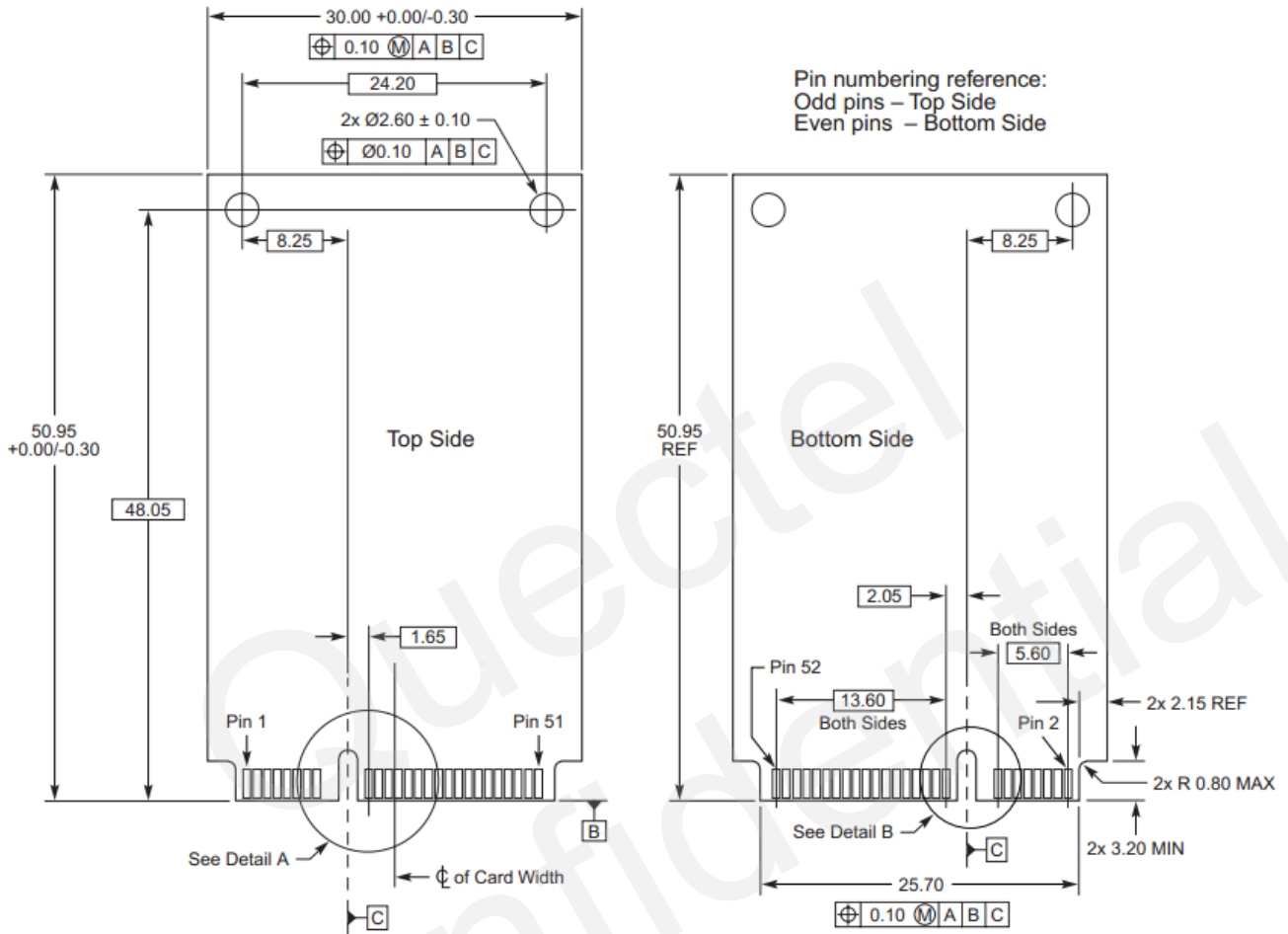

Figure 17: Standard Dimensions of Mini PCI Express (Unit: mm)

EC20 Mini PCIe adopts a standard Mini PCI Express connector which complies with the directives and standards listed in the **document [1]**. The following figure takes the Molex 679100002 as an example.

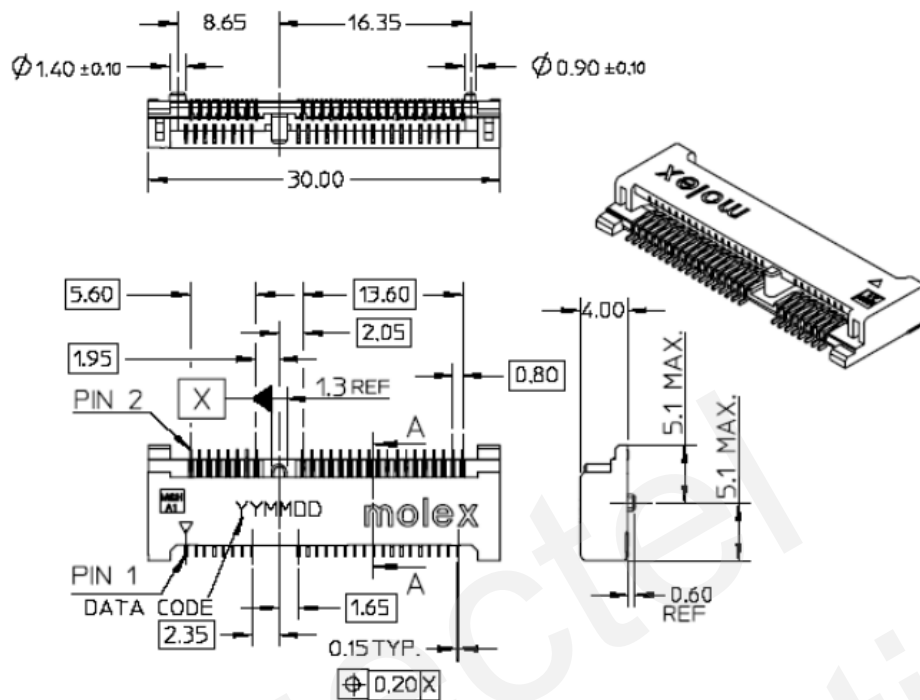

Figure 18: Dimensions of the Mini PCI Express Connector (Unit: mm)

5.4. Packaging

The EC20 Mini PCIe is packaged in tray. Each tray contains 10pcs of modules. The smallest package of EC20 Mini PCIe contains 100pcs.

6 Appendix Reference

Table 18: Related Documents

SN	Document Name	Remark
[1]	PCI Express Mini Card Electromechanical Specification Revision 1.2	Mini PCI Express Specification
[2]	Quectel_EC20_AT_Commands_Manual	EC20 AT Commands Manual
[3]	Quectel_EC20_GNSS_AT_Commands_Manual	EC20 GNSS AT Commands Manual

Table 19: Terms and Abbreviations

Abbreviation	Description
bps	Bits Per Second
CS	Coding Scheme
CS	Circuit Switched
DC-HSPA+	Dual-carrier High Speed Packet Access
DL	Down Link
ESD	Electrostatic Discharge
FDD	Frequency Division Duplexing
GLONASS	GLObalnaya Navigatsionnaya Sputnikovaya Sistema, the Russian Global Navigation Satellite System
GMSK	Gaussian Minimum Shift Keying
GNSS	Global Navigation Satellite System
GPS	Global Positioning System
GSM	Global System for Mobile Communications

HSPA	High Speed Packet Access
HSDPA	High Speed Downlink Packet Access
HSUPA	High Speed Uplink Packet Access
kbps	Kilo Bits Per Second
LED	Light Emitting Diode
LTE	Long-Term Evolution
Mbps	Million Bits Per Second
ME	Mobile Equipment (Module)
MIMO	Multiple-Input Multiple-Output
MMS	Multimedia Messaging Service
MO	Mobile Originated
MT	Mobile Terminated
PCM	Pulse Code Modulation
PDU	Protocol Data Unit
PPP	Point-to-Point Protocol
RF	Radio Frequency
Rx	Receive
USIM	Universal Subscriber Identification Module
SMS	Short Message Service
TTFF	Time To First Fix
UART	Universal Asynchronous Receiver & Transmitter
UL	Up Link
UMTS	Universal Mobile Telecommunications System
URC	Unsolicited Result Code
WCDMA	Wideband Code Division Multiple Access
