

Applications

- Wearable
- Activity tracker
- Smartwatch
- Smartglasses

Features

- Operating voltage range 2 V to 5.5 V
- Low supply current 1 μ A
- Integrated test mode
- Single Smart Reset™ push-button input with fixed extended reset setup delay (t_{SRC}) from 0.5 s to 10 s in 0.5 s steps (typ.), option with internal input pull-up resistor
- Push-button controlled reset pulse duration
 - Option 1: fully push-button controlled, no fixed or minimum pulse width guaranteed
 - Option 2: defined output reset pulse duration (t_{REC}), factory-programmed
- Single reset output
 - Active low or active high
 - Push-pull or open drain with optional pull-up resistor
- Fixed Smart Reset input logic voltage levels
- Operating temperature: -40 °C to +85 °C
- UDFN6 package 1.00 mm x 1.45 mm
- ECOPACK®2 (RoHS compliant, Halogen-Free)

Contents

- 1 Description 3**
 - 1.1 Test mode 3
 - 1.2 Logic diagram 4
 - 1.3 Pin connections 4
- 2 Device overview 5**
- 3 Pin descriptions 6**
 - 3.1 Power supply (V_{CC}) 6
 - 3.2 Power-up sequence 6
 - 3.3 Ground (V_{SS}) 6
 - 3.4 Smart Reset input (\overline{SR}) 6
 - 3.5 Reset output (\overline{RST}) 6
 - 3.6 \overline{RST} output undervoltage behavior (for open-drain option) 6
- 4 Typical application diagrams 7**
- 5 Timing diagrams 9**
- 6 Typical operating characteristics 10**
- 7 Maximum ratings 12**
- 8 DC and AC parameters 13**
- 9 Package information 15**
- 10 Tape and reel information 17**
- 11 Part numbering 18**
- 12 Package marking information 19**
- 13 Revision history 20**

1 Description

The Smart Reset™ devices provide a useful feature which ensures that inadvertent short reset push-button closures do not cause system resets. This is done by implementing an extended Smart Reset input delay time (t_{SRC}), which ensures a safe reset and eliminates the need for a specific dedicated reset button.

This reset configuration provides versatility and allows the application to distinguish between a software generated interrupt and a hard system reset. When the input push-button is connected to the microcontroller interrupt input, and is closed for a short time, the processor can only be interrupted. If the system still does not respond properly, continuing to keep the push-button closed for the extended setup time t_{SRC} causes a hard reset of the processor through the reset output.

The SR1 has one Smart Reset input (\overline{SR}) with preset delayed Smart Reset setup time (t_{SRC}). The reset output (\overline{RST}) is asserted after the Smart Reset input is held active for the selected t_{SRC} delay time. The \overline{RST} output remains asserted either until the \overline{SR} input goes to inactive logic level (i.e. neither fixed nor minimum reset pulse width is set) or the output reset pulse duration is fixed for t_{REC} (i.e. factory-programmed). The device fully operates over a broad V_{CC} range from 2.0 V to 5.5 V.

1.1 Test mode

After pulling \overline{SR} up to V_{TEST} ($V_{CC} + 1.4$ V) or above, the counter starts to count the initial shortened $t_{SRC-INI}$ (42 ms, typ.). After $t_{SRC-INI}$ expires, the \overline{RST} output either goes down for t_{REC} (if t_{REC} option is used) or stays low as long as overvoltage on \overline{SR} is detected (if t_{REC} option is not used). This is feedback, and the user only knows that the device is locked in test mode. Each time the \overline{SR} input is connected to ground in test mode, a shortened $t_{SRC-SHORT}$ ($t_{SRC}/128$) is used instead of regular t_{SRC} (0.5 s - 10 s). In this way the device can be quickly tested without repeating test mode triggering. Return to normal mode is possible by performing a new startup of the device (i.e. V_{CC} goes to 0 V and back to its original state).

The advantages of this solution are its high glitch immunity, user feedback regarding entry into test mode, and testability within the full V_{CC} range.

1.2 Logic diagram

Figure 1. SR1 logic diagram

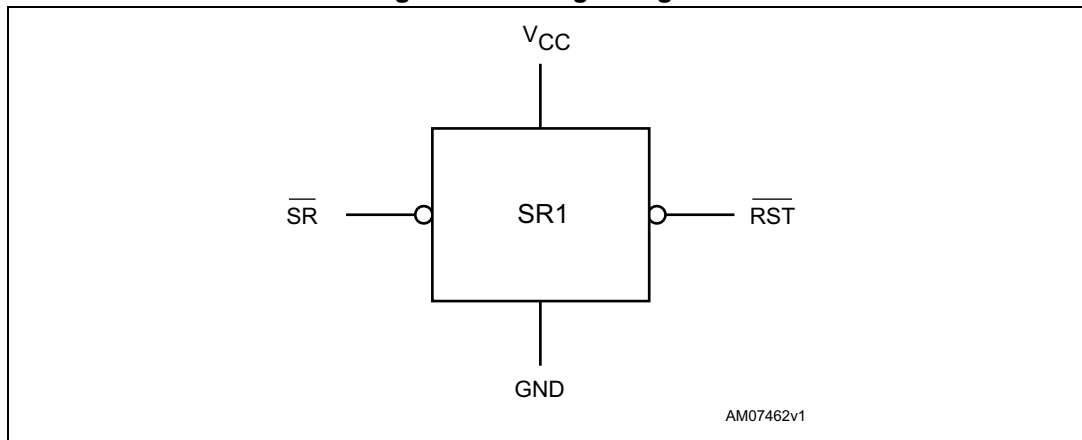

1.3 Pin connections

Figure 2. UDFN6 pin connections (top view)

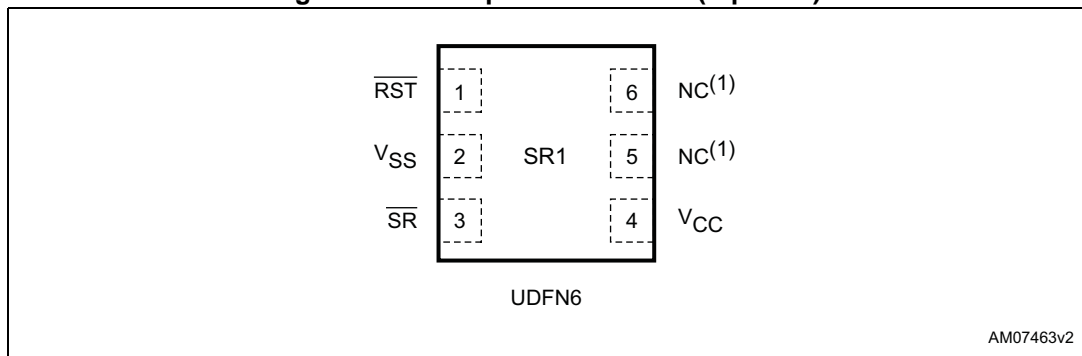

1. Not connected (not bonded); should be connected to V_{SS} .

2 Device overview

Table 1. Signal names

Pin n°	Name	Type	Description
1	$\overline{\text{RST}}$	Output	Reset output, active low, open drain.
2	V_{SS}	Supply ground	Ground
3	$\overline{\text{SR}}$	Input	Smart Reset input, active low.
4	V_{CC}	Supply voltage	Positive supply voltage for the device. A 0.1 μF decoupling ceramic capacitor is recommended to be connected between V_{CC} and V_{SS} pins.
5	NC	-	Not connected (not bonded); should be connected to V_{SS} .
6	NC	-	Not connected (not bonded); should be connected to V_{SS} .

Figure 3. SR1 block diagram

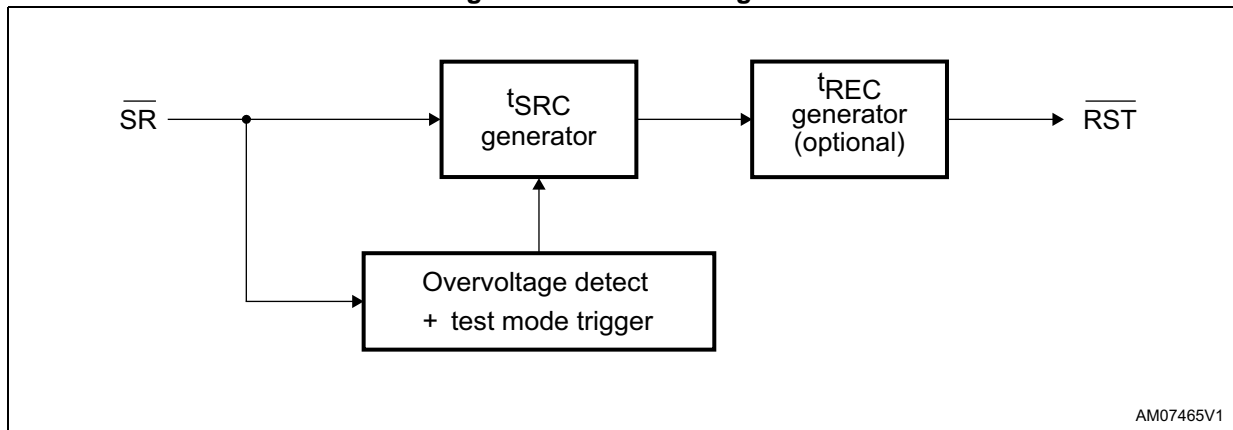

3 Pin descriptions

3.1 Power supply (V_{CC})

This pin is used to provide power to the Smart Reset device. A 0.1 μF ceramic decoupling capacitor is recommended to be connected between the V_{CC} and V_{SS} pins, as close to the SR1 device as possible.

3.2 Power-up sequence

In normal mode, if different input side ($\overline{\text{SR}}$) and V_{CC} voltage domains are used, power-on sequence must avoid meeting the test mode entry condition to avoid inadvertent test mode entry: there should not be logic high present on the $\overline{\text{SR}}$ input before the V_{CC} power-up. However V_{CC} and $V(\overline{\text{SR}})$ rising at the same time is OK (e.g. if both are in the same voltage domain), the device will then safely start into normal operating mode, with $\overline{\text{RST}}$ output inactive (in High-Z mode for open-drain option).

3.3 Ground (V_{SS})

This is the ground pin for the device.

3.4 Smart Reset input ($\overline{\text{SR}}$)

Push-button Smart Reset input, active low with optional pull-up resistor. $\overline{\text{SR}}$ input needs to be asserted for at least t_{SRC} to assert the reset output ($\overline{\text{RST}}$).

By connecting a voltage higher than $V_{CC} + 1.4 \text{ V}$ to the $\overline{\text{SR}}$ input the device enters test mode (see [Section 1: Description on page 3](#) for more information).

3.5 Reset output ($\overline{\text{RST}}$)

$\overline{\text{RST}}$ is active low or active high, open drain or push-pull reset output with optional internal pull-up resistor.

Output reset pulse width is optional as follows:

- Neither fixed nor minimum output reset pulse duration (releasing the push-button while reset output is active, causes the output to de-assert)
- Fixed, factory-programmed output reset pulse duration for t_{REC} independent on Smart Reset input state.

3.6 $\overline{\text{RST}}$ output undervoltage behavior (for open-drain option)

High-Z on $\overline{\text{RST}}$ output below the specified operating voltage range is guaranteed at V_{CC} power-on or in case that valid V_{CC} dropped while the device was idle, i.e. while both output and input were inactive.

4 Typical application diagrams

Figure 4. Typical application diagram - input, output and SR1 device in one voltage domain

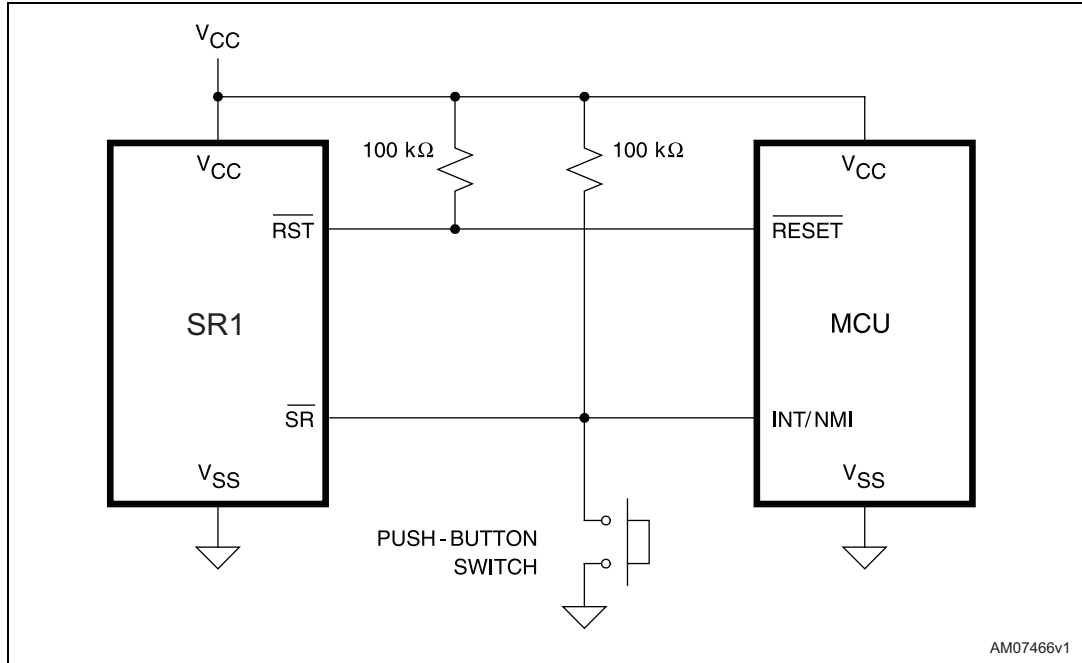
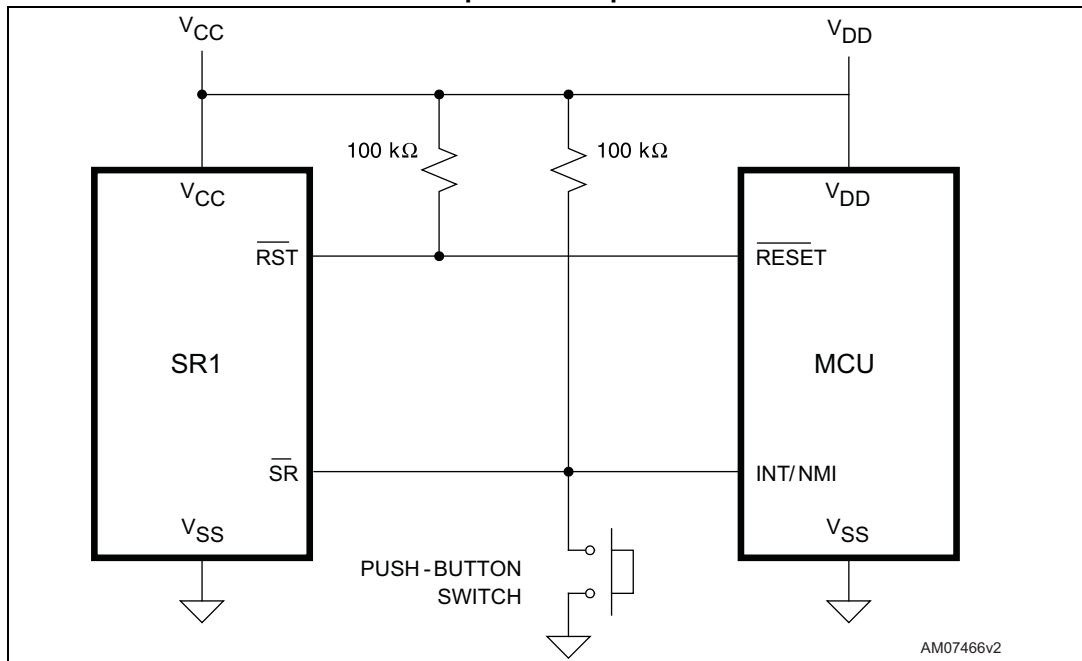
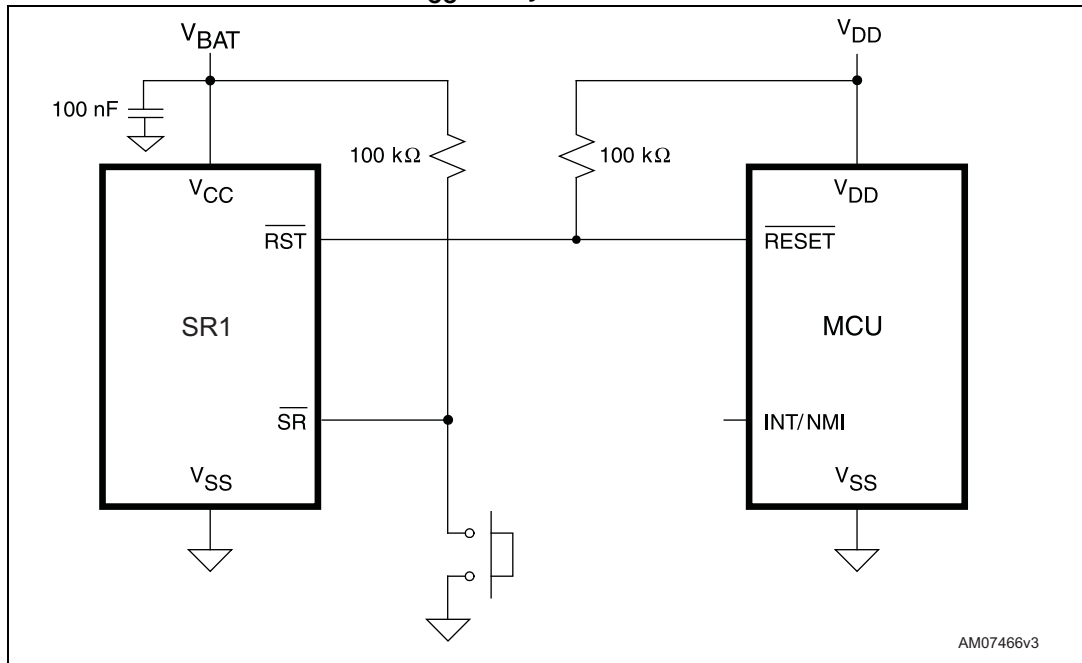

Figure 5. Typical application diagram - SR1 device in a different voltage domain than input and output



1. Open-drain \overline{RST} output type and fixed \overline{SR} input logic threshold allows to use the device in different voltage domains. To prevent entering test mode by creating a condition $V(SR) > V_{CC} + 1.1 \text{ V typ.}$, V_{CC} should be powered up before or together with voltage on the SR input.

Figure 6. Typical application diagram in different voltage domains - \overline{SR} input in V_{BAT} domain like V_{CC} totally disables the test mode



5 Timing diagrams

Figure 7. $\overline{\text{RST}}$ output without t_{REC} option

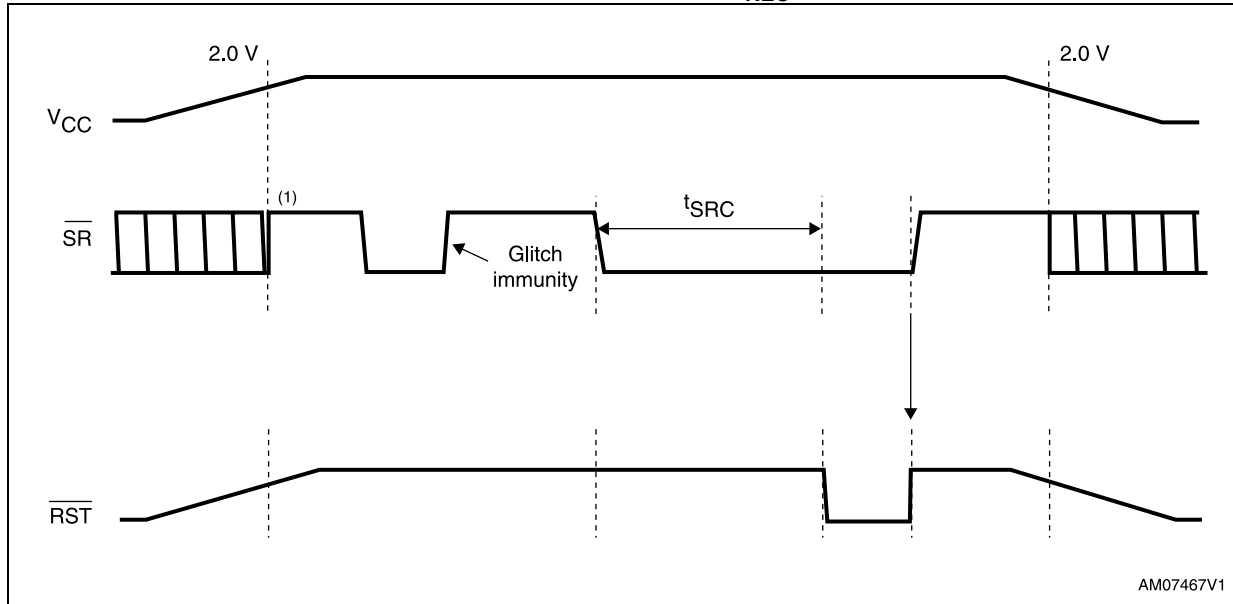

1. V_{CC} should be powered up before or together with voltage on the $\overline{\text{SR}}$ input to prevent entering test mode by creating a condition $V(\overline{\text{SR}}) > V_{CC} + 1.1 \text{ V typ.}$

Figure 8. $\overline{\text{RST}}$ output with t_{REC} option

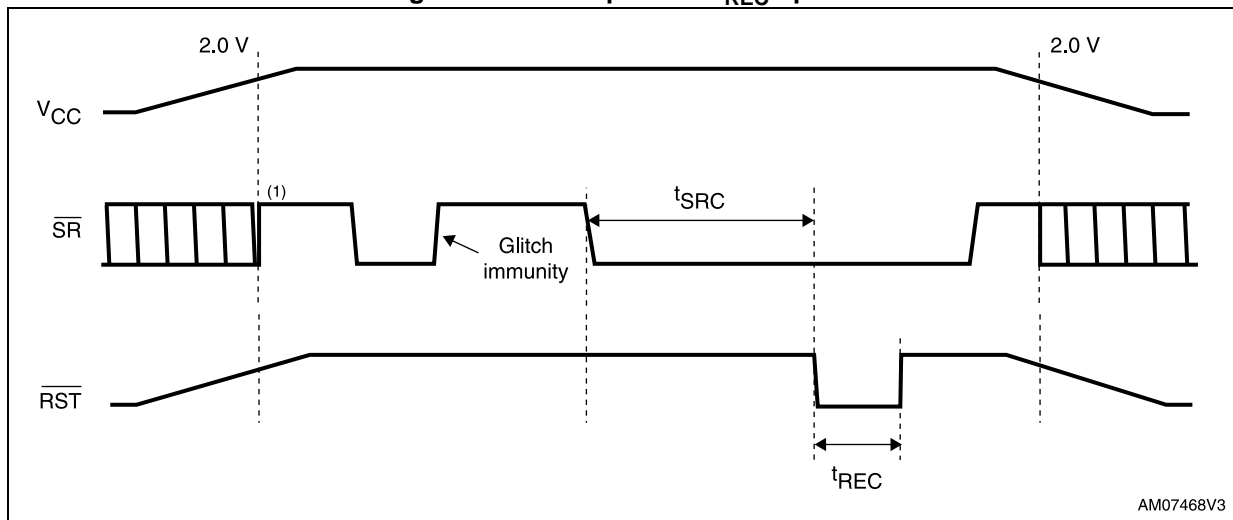

1. V_{CC} should be powered up before or together with voltage on the $\overline{\text{SR}}$ input to prevent entering test mode by creating a condition $V(\overline{\text{SR}}) > V_{CC} + 1.1 \text{ V typ.}$

6 Typical operating characteristics

Figure 9. Supply current (I_{CC}) vs. temperature (T_A)

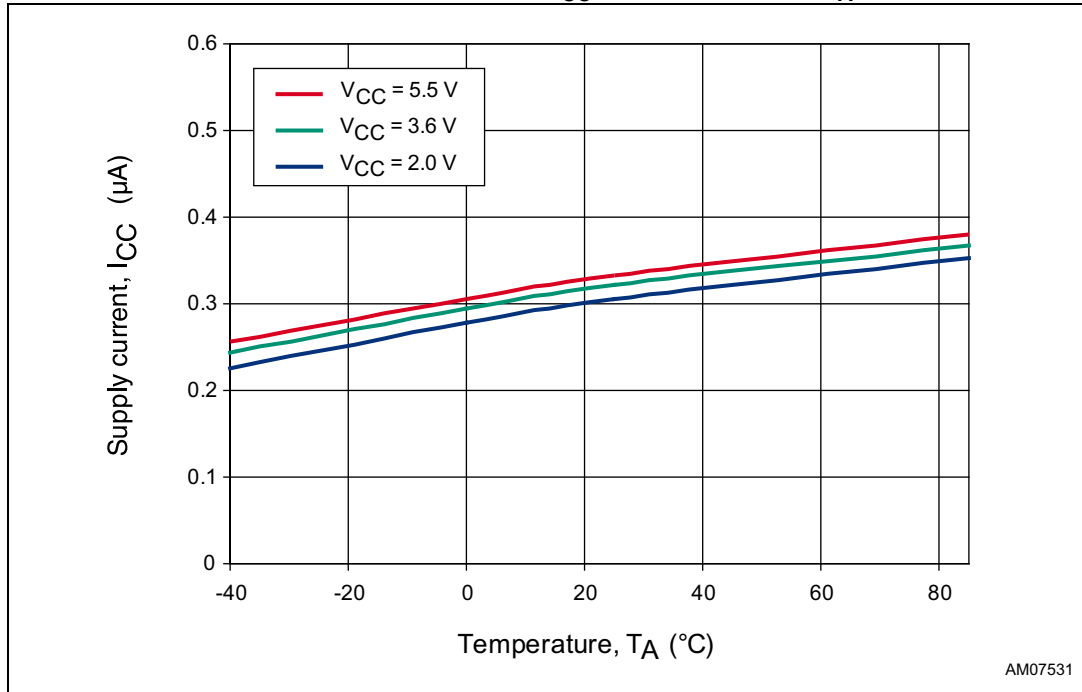

Figure 10. Smart Reset delay (t_{SRC}) vs. temperature (T_A), $t_{SRC} = 4.0 s$ (typ.)

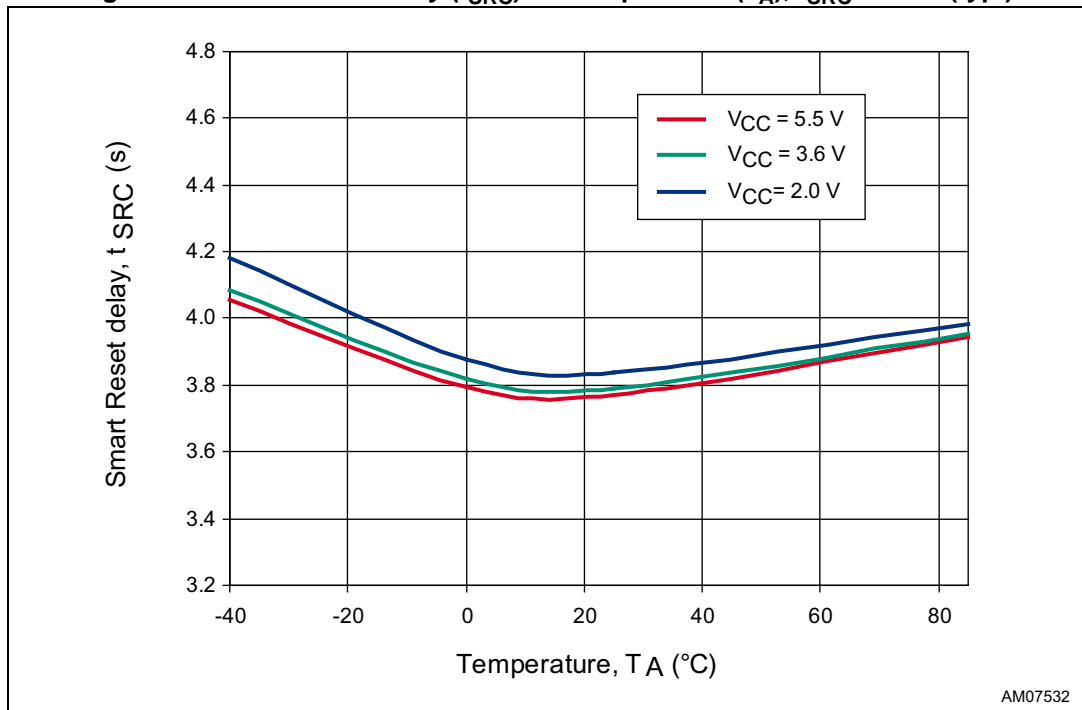

Figure 11. Test mode entry voltage (V_{TEST}) vs. temperature (T_A)

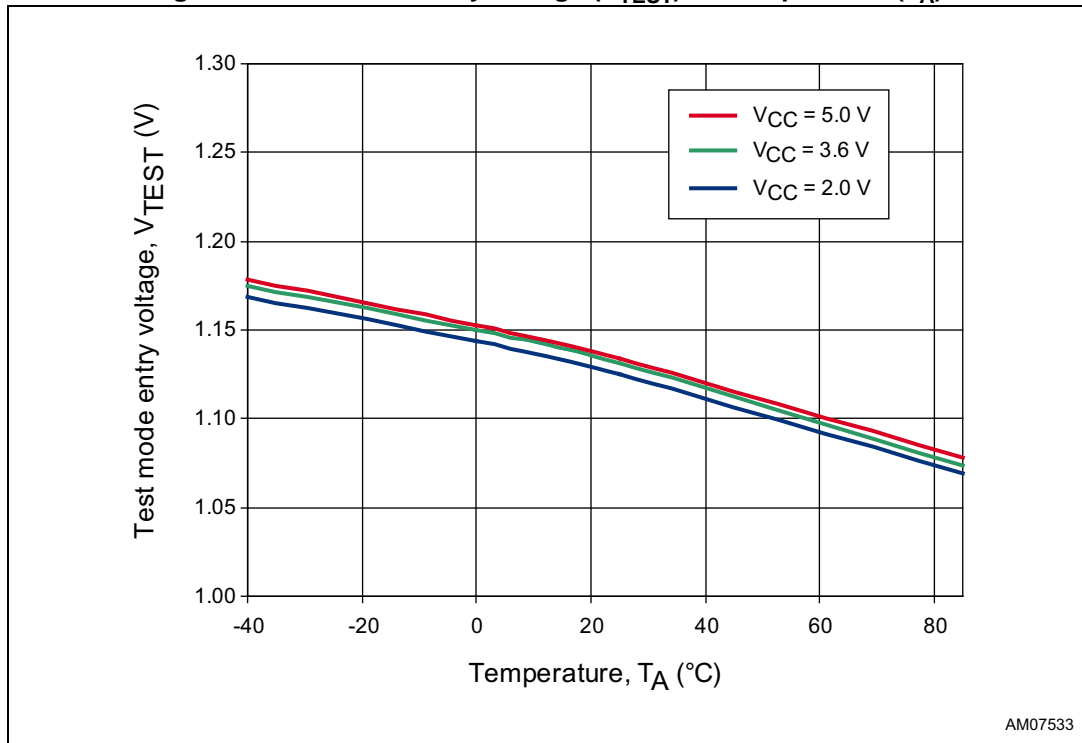
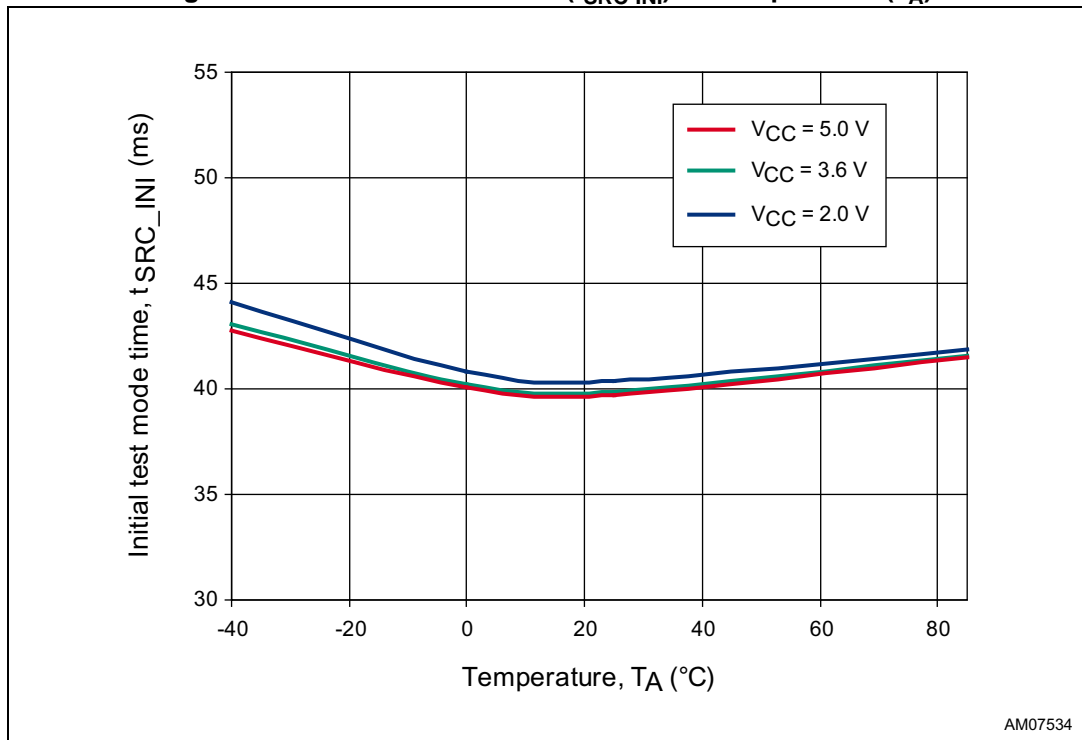

Figure 12. Initial test mode time (t_{SRC_INI}) vs. temperature (T_A)



7 Maximum ratings

Stressing the device above the rating listed in [Table 2: Absolute maximum ratings](#) may cause permanent damage to the device. These are stress ratings only and operation of the device at these or any other conditions above those indicated in [Table 3: Operating and measurement conditions](#) of this specification is not implied. Exposure to absolute maximum rating conditions for extended periods may affect device reliability. Refer also to the STMicroelectronics™ SURE program and other relevant quality documents.

Table 2. Absolute maximum ratings

Symbol	Parameter	Value	Unit
T_{STG}	Storage temperature (V_{CC} off)	-55 to +150	°C
$T_{SLD}^{(1)}$	Lead solder temperature for 10 seconds	260	°C
V_{IO}	Input or output voltage	-0.3 to 5.5	V
V_{CC}	Supply voltage	-0.3 to 7	V
ESD			
V_{HBM}	Electrostatic discharge protection, human body model (JESD22-A114-B level 2)	2	kV
V_{RCDM}	Electrostatic discharge protection, charged device model, all pins	1	kV
V_{MM}	Electrostatic discharge protection, machine model, all pins (JESD22-A115-A level A)	200	V
	Latch-up (V_{CC} pin, \overline{SR} reset input pin)	EIA/JESD78	

1. Reflow at peak temperature of 260 °C. The time above 255 °C must not exceed 30 seconds.

8 DC and AC parameters

This section summarizes the operating measurement conditions, and the DC and AC characteristics of the device. The parameters in [Table 4: DC and AC characteristics](#) are derived from tests performed under the measurement conditions summarized in [Table 3: Operating and measurement conditions](#). Designers should check that the operating conditions in their circuit match the operating conditions when relying on the quoted parameters.

Table 3. Operating and measurement conditions

Symbol	Parameter	Value	Unit
V_{CC}	Supply voltage	2.0 to 5.5	V
T_A	Ambient operating temperature	-40 to +85	°C
t_R, t_F	Input rise and fall times	≤ 5	ns
	Input pulse voltages	0.2 to 0.8 V_{CC}	V
	Input and output timing reference voltages	0.3 to 0.7 V_{CC}	V

Table 4. DC and AC characteristics

Symbol	Parameter	Test conditions ⁽¹⁾	Min.	Typ. ⁽²⁾	Max.	Unit
V _{CC}	Supply voltage		2.0		5.5	V
I _{CC}	Supply current	$\overline{SR} = V_{CC}$, t _{REC} and t _{SRC} counter is not running		0.4	1.0	μA
V _{OL}	Reset output voltage low	V _{CC} ≥ 4.5 V, sinking 3.2 mA			0.3	V
		V _{CC} ≥ 3.3 V, sinking 2.5 mA			0.3	V
		V _{CC} ≥ 2.0 V, sinking 1 mA			0.3	V
t _{REC}	Reset timeout delay, factory-programmed	(device option)	140	210	280	ms
			240	360	480	ms
R _{PUO}	Internal output pull-up resistor on RST	(device option)		65		kΩ
I _{LO}	Output leakage current	V _{RST} = 5.5 V, open drain device option without output pull-up resistor	-0.1		0.1	μA
Smart Reset						
t _{SRC}	Smart Reset delay	T _A = -40 to +85 °C	0.8 x t _{SRC}	t _{SRC} ⁽³⁾	1.2 x t _{SRC}	s
		T _A = 25 °C	0.9 x t _{SRC}		1.1 x t _{SRC}	
V _{IL}	\overline{SR} input voltage low		V _{SS} -0.3		0.3	V
V _{IH}	\overline{SR} input voltage high		0.85		5.5	V
R _{PUI}	Internal input pull-up resistor on SR	(device option)		65		kΩ
I _{LEAK}	\overline{SR} input leakage current	device option without input pull-up resistor	-0.1		0.1	μA
	Input glitch immunity			t _{SRC}		s
Test mode						
V _{TEST}	Test mode entry voltage		V _{CC} +0.9	V _{CC} +1.1	V _{CC} +1.4	V
t _{SRC-INI}	Initial test mode time		28	42	56	ms
t _{SRC-SHORT}	Shortened Smart Reset delay			t _{SRC} / 128		ms

1. Valid for ambient operating temperature T_A = -40 to +85 °C, V_{CC} = 2.0 to 5.5 V.

2. Typical values are at 25 °C and V_{CC} = 3.3 V unless otherwise noted.

3. Factory-programmable in the range of 0.5 s to 10 s typ. in 0.5 s steps.

9 Package information

In order to meet environmental requirements, ST offers these devices in different grades of ECOPACK[®] packages, depending on their level of environmental compliance. ECOPACK specifications, grade definitions and product status are available at: www.st.com. ECOPACK is an ST trademark.

Figure 13. UDFN6, (1.00 x 1.45 x 0.50 mm), 0.50 mm pitch package outline

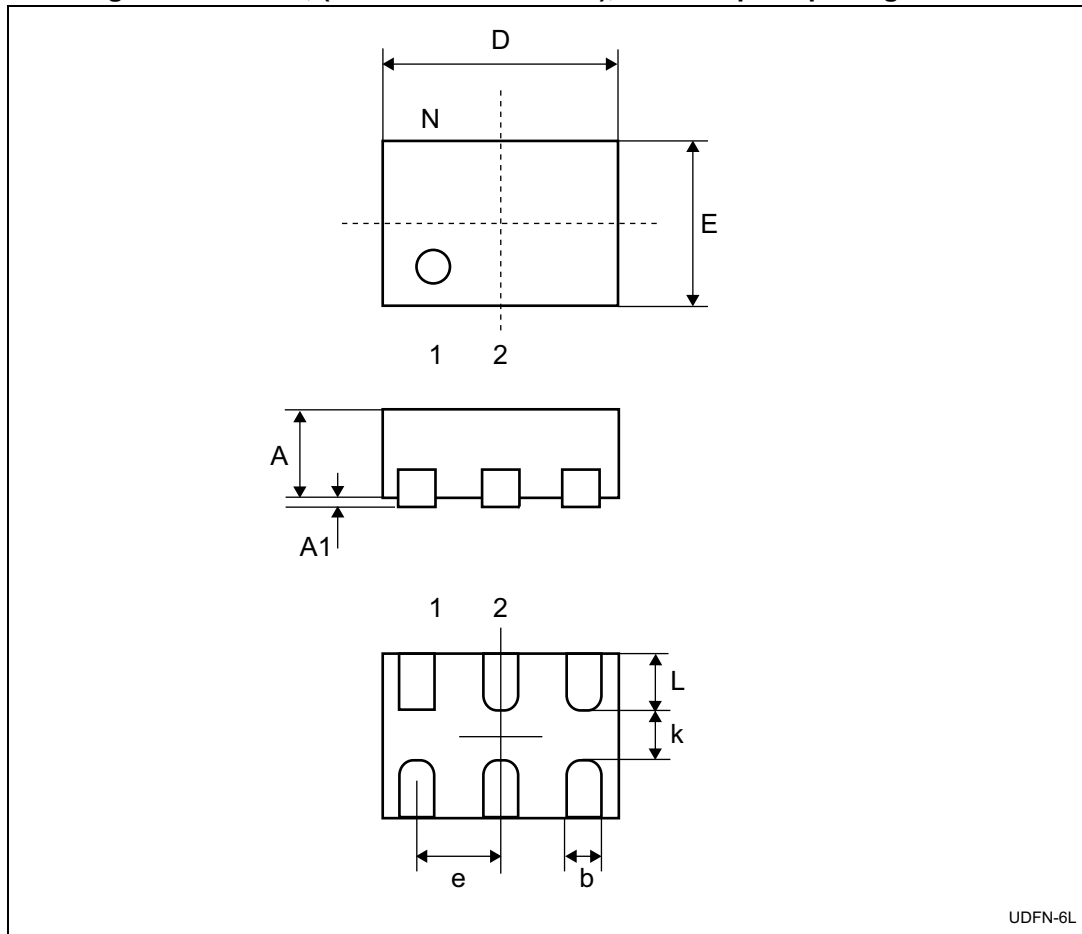
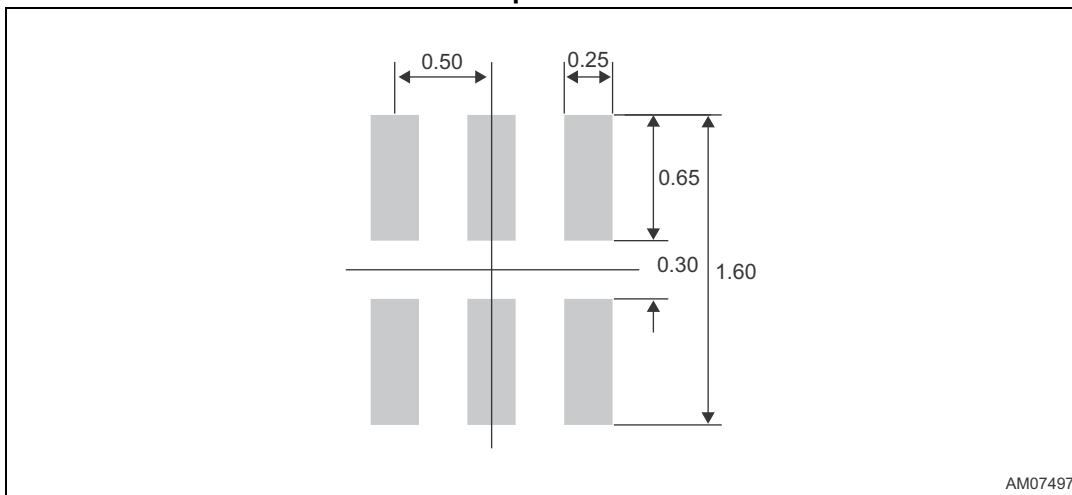

Table 5. UDFN6, (1.00 x 1.45 x 0.50 mm), 0.50 mm pitch package mechanical data

Symbol	Dimensions						Note ⁽¹⁾
	(mm)			(inches)			
	Min.	Typ.	Max.	Min.	Typ.	Max.	
A	0.50	0.55	0.60	0.0197	0.0217	0.0236	
A1	0.00	0.02	0.05	0.000	0.0008	0.0020	
b	0.18	0.25	0.30	0.0071	0.0098	0.0118	
D	1.40	1.45	1.50	0.0551	0.0571	0.0591	
E	0.95	1.00	1.05	0.0374	0.0394	0.0413	
e	0.45	0.50	0.55	0.0177	0.0197	0.0217	
k	0.20			0.0079			
L	0.30	0.35	0.40	0.0118	0.0138	0.0157	

1. Package outline exclusive of any mold flashes dimensions and metal burrs.

Figure 14. Footprint recommendation for UDFN6 (1.00 x 1.45 x 0.50 mm), 0.50 mm pitch



AM07497

10 Tape and reel information

Figure 15. Carrier tape

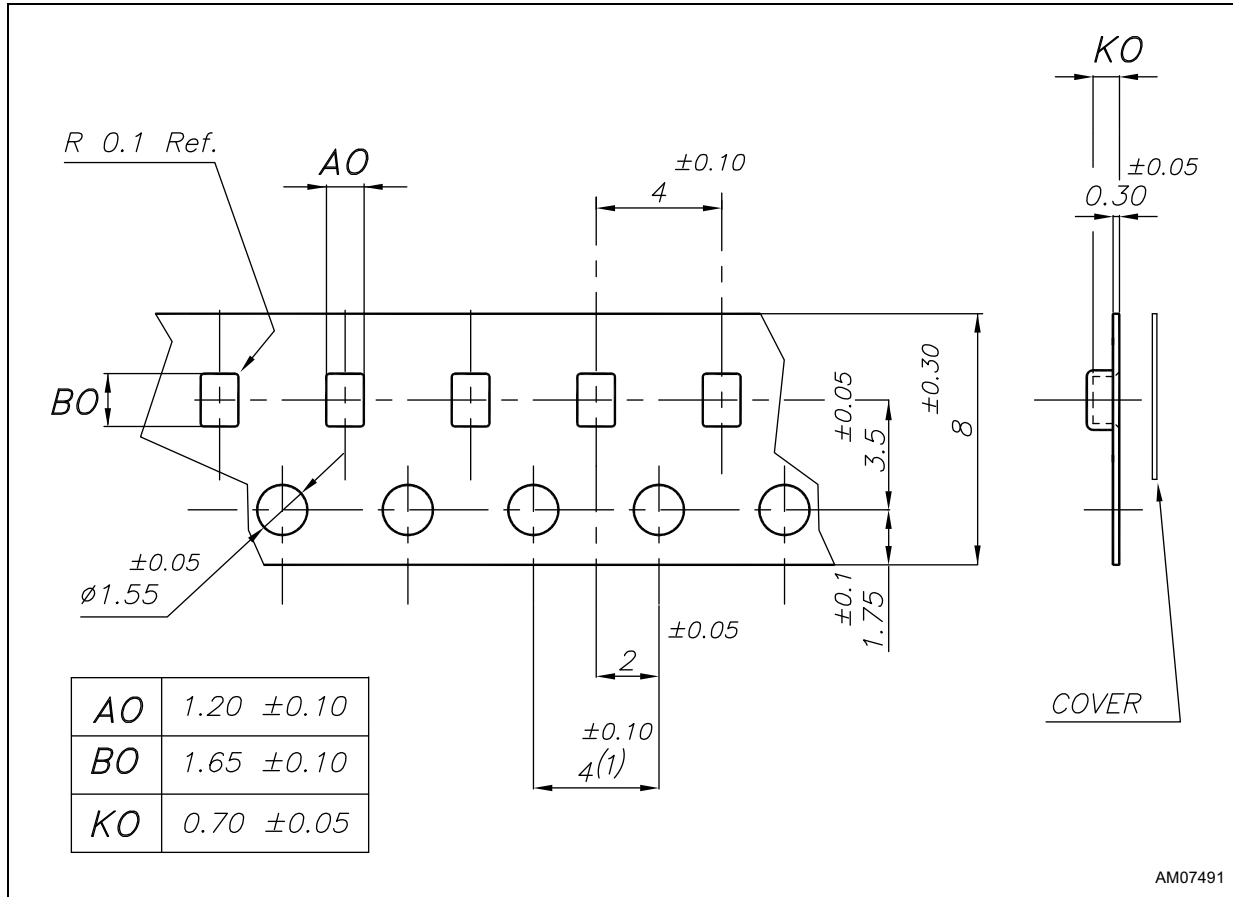

1. 10-sprocket hole pitch cumulative tolerance ±0.20.

Figure 16. Pin 1 orientation

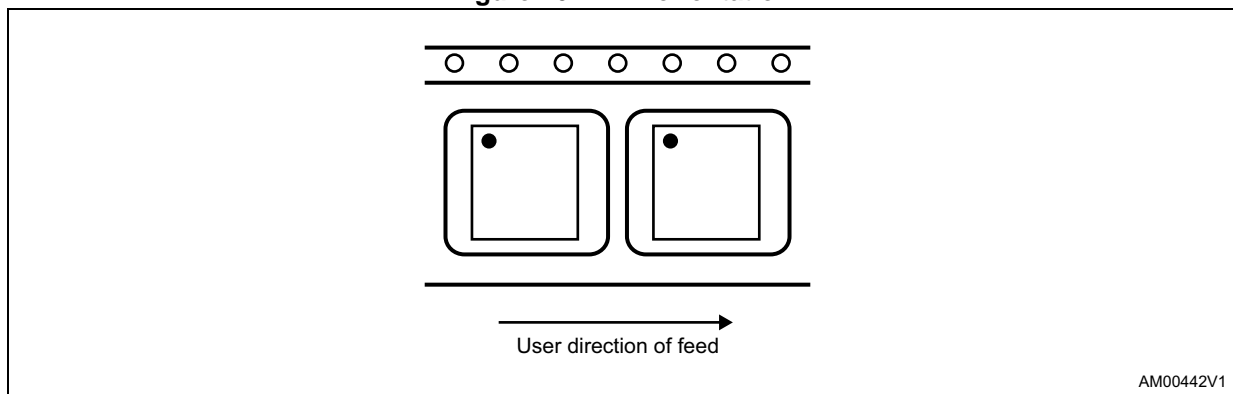

AM00442V1

11 Part numbering

Table 6. Ordering information scheme

Example:	SR1	H	A	R	U
Device type					
SR1					
Smart Reset setup delay (t_{SRC})⁽¹⁾					
C = factory programmable $t_{SRC} = 1.5$ s (typ.)					
H = factory programmable $t_{SRC} = 4.0$ s (typ.)					
L = factory programmable $t_{SRC} = 6.0$ s (typ.)					
P = factory programmable $t_{SRC} = 7.5$ s (typ.)					
U = factory programmable $t_{SRC} = 10.0$ s (typ.)					
Inputs, outputs type⁽²⁾					
A = active low \overline{SR} input with no pull-up, active low open drain \overline{RST} output with no pull-up					
B = active low \overline{SR} input with pull-up, active low open drain \overline{RST} output with no pull-up					
Reset timeout period (t_{REC})					
A = factory programmable $t_{REC} = 210$ ms (typ.)					
B = factory programmable $t_{REC} = 360$ ms (typ.)					
R = push-button controlled (no defined t_{REC})					
Package					
U = UDFN-6L					

1. Smart Reset delay (t_{SRC}) is available from 0.5 s to 10 s in 0.5 s steps (typ.). Minimum order quantities may apply. Contact local sales office for availability.
2. Push-pull reset output type also available (active low or active high). \overline{SR} input and open drain reset output available with optional pull-up resistor. Minimum order quantities may apply. Contact local sales office for availability.

12 Package marking information

Table 7. Package marking

Part number	t_{SRC} (s)	Smart Reset inputs ⁽¹⁾	Output type ⁽²⁾	t_{REC} option ⁽³⁾	Package	Topmark
SR1CARU	1.5	AL	OD, AL	No t_{REC}	UDFN6	CA
SR1HARU	4.0	AL	OD, AL	No t_{REC}	UDFN6	HA
SR1LARU	6.0	AL	OD, AL	No t_{REC}	UDFN6	LA
SR1PAAU	7.5	AL	OD, AL	210 ms	UDFN6	PB
SR1PARU	7.5	AL	OD, AL	No t_{REC}	UDFN6	PA
SR1PBBU	7.5	AL + pull-up	OD, AL	360 ms	UDFN6	PC
SR1UARU	10.0	AL	OD, AL	No t_{REC}	UDFN6	UA

1. AL = active low.
2. OD = open drain, AL = active low.
3. No t_{REC} = push-button controlled reset pulse width, any other value represents typical value of t_{REC} .

Figure 17. Package marking (top view)

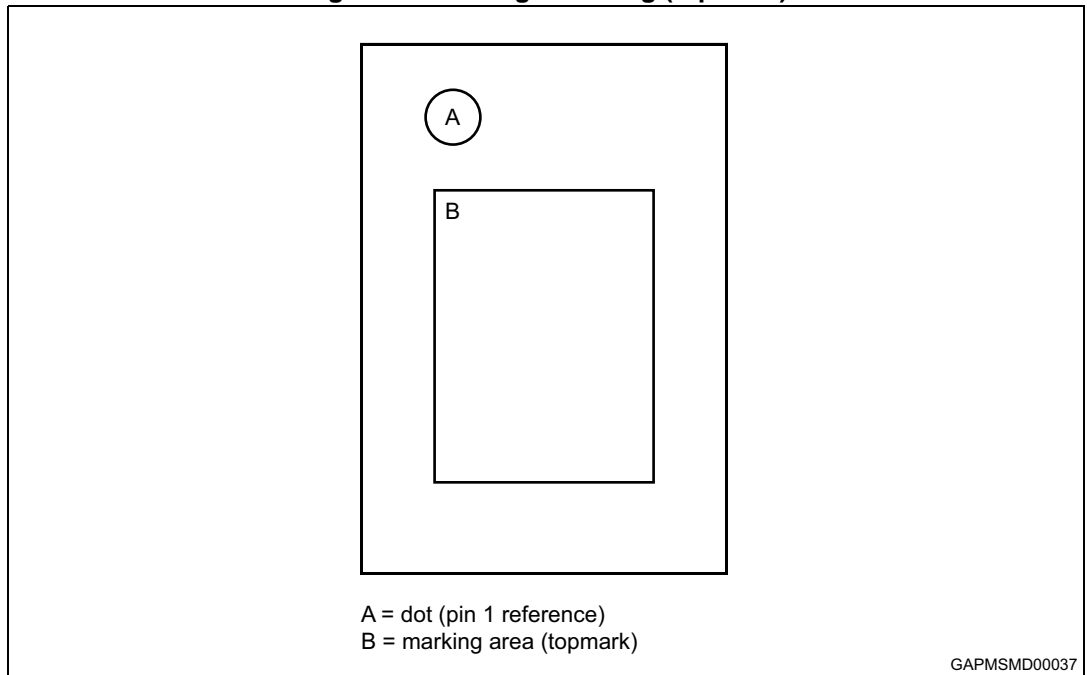

13 Revision history

Table 8. Document revision history

Date	Revision	Changes
10-Mar-2014	1	Initial release
13-May-2014	2	Modified t_{REC} values Table 4 on page 14

Please Read Carefully:

Information in this document is provided solely in connection with ST products. STMicroelectronics NV and its subsidiaries ("ST") reserve the right to make changes, corrections, modifications or improvements, to this document, and the products and services described herein at any time, without notice.

All ST products are sold pursuant to ST's terms and conditions of sale.

Purchasers are solely responsible for the choice, selection and use of the ST products and services described herein, and ST assumes no liability whatsoever relating to the choice, selection or use of the ST products and services described herein.

No license, express or implied, by estoppel or otherwise, to any intellectual property rights is granted under this document. If any part of this document refers to any third party products or services it shall not be deemed a license grant by ST for the use of such third party products or services, or any intellectual property contained therein or considered as a warranty covering the use in any manner whatsoever of such third party products or services or any intellectual property contained therein.

UNLESS OTHERWISE SET FORTH IN ST'S TERMS AND CONDITIONS OF SALE ST DISCLAIMS ANY EXPRESS OR IMPLIED WARRANTY WITH RESPECT TO THE USE AND/OR SALE OF ST PRODUCTS INCLUDING WITHOUT LIMITATION IMPLIED WARRANTIES OF MERCHANTABILITY, FITNESS FOR A PARTICULAR PURPOSE (AND THEIR EQUIVALENTS UNDER THE LAWS OF ANY JURISDICTION), OR INFRINGEMENT OF ANY PATENT, COPYRIGHT OR OTHER INTELLECTUAL PROPERTY RIGHT.

ST PRODUCTS ARE NOT DESIGNED OR AUTHORIZED FOR USE IN: (A) SAFETY CRITICAL APPLICATIONS SUCH AS LIFE SUPPORTING, ACTIVE IMPLANTED DEVICES OR SYSTEMS WITH PRODUCT FUNCTIONAL SAFETY REQUIREMENTS; (B) AERONAUTIC APPLICATIONS; (C) AUTOMOTIVE APPLICATIONS OR ENVIRONMENTS, AND/OR (D) AEROSPACE APPLICATIONS OR ENVIRONMENTS. WHERE ST PRODUCTS ARE NOT DESIGNED FOR SUCH USE, THE PURCHASER SHALL USE PRODUCTS AT PURCHASER'S SOLE RISK, EVEN IF ST HAS BEEN INFORMED IN WRITING OF SUCH USAGE, UNLESS A PRODUCT IS EXPRESSLY DESIGNATED BY ST AS BEING INTENDED FOR "AUTOMOTIVE, AUTOMOTIVE SAFETY OR MEDICAL" INDUSTRY DOMAINS ACCORDING TO ST PRODUCT DESIGN SPECIFICATIONS. PRODUCTS FORMALLY ESCC, QML OR JAN QUALIFIED ARE DEEMED SUITABLE FOR USE IN AEROSPACE BY THE CORRESPONDING GOVERNMENTAL AGENCY.

Resale of ST products with provisions different from the statements and/or technical features set forth in this document shall immediately void any warranty granted by ST for the ST product or service described herein and shall not create or extend in any manner whatsoever, any liability of ST.

ST and the ST logo are trademarks or registered trademarks of ST in various countries.

Information in this document supersedes and replaces all information previously supplied.

The ST logo is a registered trademark of STMicroelectronics. All other names are the property of their respective owners.

© 2014 STMicroelectronics - All rights reserved

STMicroelectronics group of companies

Australia - Belgium - Brazil - Canada - China - Czech Republic - Finland - France - Germany - Hong Kong - India - Israel - Italy - Japan - Malaysia - Malta - Morocco - Philippines - Singapore - Spain - Sweden - Switzerland - United Kingdom - United States of America

www.st.com



Mouser Electronics

Authorized Distributor

Click to View Pricing, Inventory, Delivery & Lifecycle Information:

[STMicroelectronics:](#)

[SR1LARU](#) [SR1PBBU](#) [SR1PAAU](#) [SR1PARU](#) [SR1CARU](#) [SR1HARU](#)