

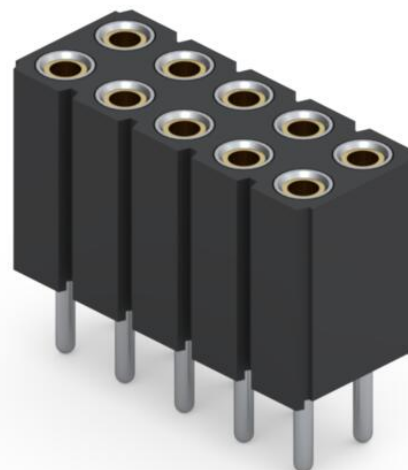

PRODUCT NUMBER: 803-93-010-10-001000

www.mill-max.com  
DATA SHEET

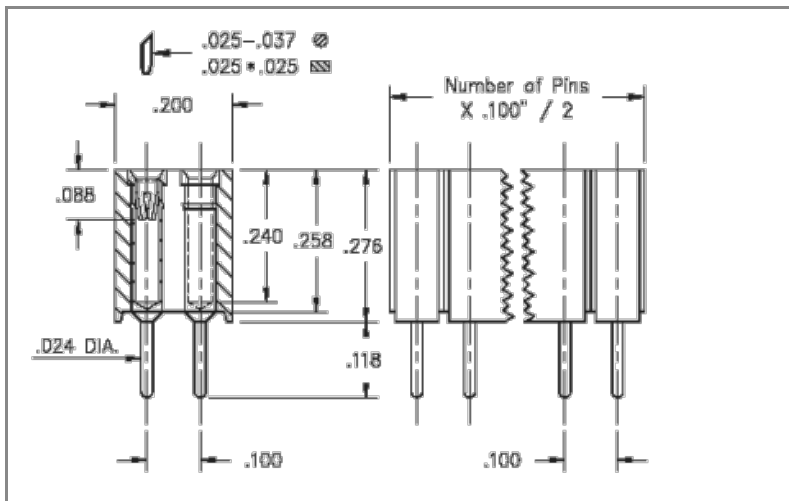

## 803-93-010-10-001000- SPECIFICATIONS

General Info	
<b>Description<sup>1</sup>:</b>	Standard Solder Tail Socket Accepts .025"-.037" (0,635-0,940mm) dia leads
<b>Type:</b>	Interconnect
<b>Category:</b>	Machined Pin Socket
<b>Mounting Style:</b>	Through Hole Solder Mount
<b># Pins:</b>	10
<b>RoHS:</b>	No
<b>Product Lifecycle:</b>	Active

Materials	
<b>Shell Plating:</b>	200 μ" Tin/Lead(93/7) over 100 μ" Nickel
<b>Inner Contact Plating:</b>	30 μ" Gold over 50 μ" Nickel
<b>Loose Pin/Receptacle Used:</b>	1304 (Brass Alloy)
<b>Insulator Material:</b>	PCT

Technical Specs	
<b>Temperature Range<sup>2</sup>:</b>	-55/+125° C
<b>Pitch:</b>	.100" (2,540mm)
<b>Rows:</b>	Double Row (2)

## NOTES:

### 1. Standard Tolerances

Assembly tolerance: +/- .010" (.25mm)

Connector Length "L"

Connector Length "L"	Tolerance
$L \leq 2"$ ( $L \leq 50.8$ mm)	+/- .005" (+/- .127 mm)
$2 < L \leq 3"$ ( $50.8 < L \leq 76.2$ mm)	+ .007 / - .006" (+ .178 / - .152 mm)
$3 < L \leq 4"$ ( $76.2 < L \leq 101.6$ mm)	+ .009 / - .007" (+ .229 / - .178 mm)
$4 < L \leq 5"$ ( $101.6 < L \leq 127$ mm)	+ .011 / - .008" (+ .279 / - .203 mm)
$5 < L \leq 6.4"$ ( $127 < L \leq 162.56$ mm)	+ .013 / - .009" (+ .330 / - .229 mm)

Insulator width: +/- .005 (.13mm)

Insulator height: +/- .005 (.13mm)

Co-planarity of SMT connectors: .005" (.13mm) up to 1" (25.4mm) in connector length

Insulator Flatness: .005" (.13mm) up to 1" (25.4mm) in connector length

Pin Length: +/- .005 (.13mm)

Pin Diameter: +/- .002 (.051mm)

Pin Angle: +/- 2°

### 2. Per IEC 60512-11-(4,-9,-10,-12)

## CONTACT:

### #47 CONTACT

FOR .025"-.037" DIA. & .025" SQ. ( $\delta = .011$ )  
6-FINGER (BeCu), GROUP D

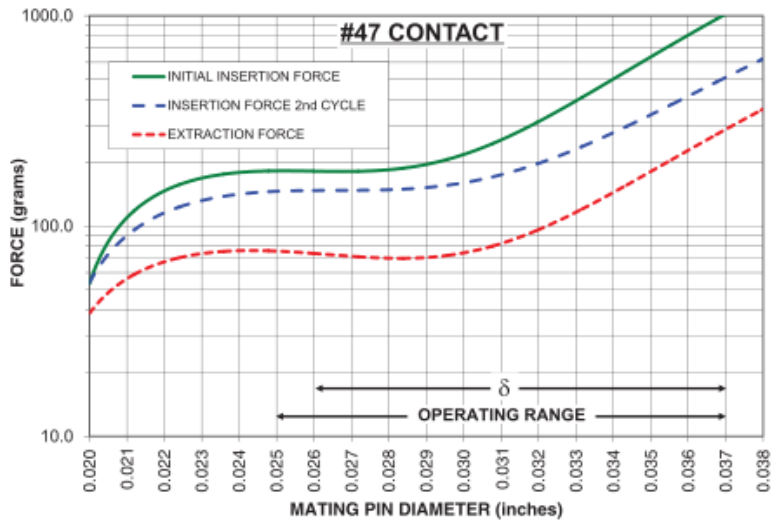
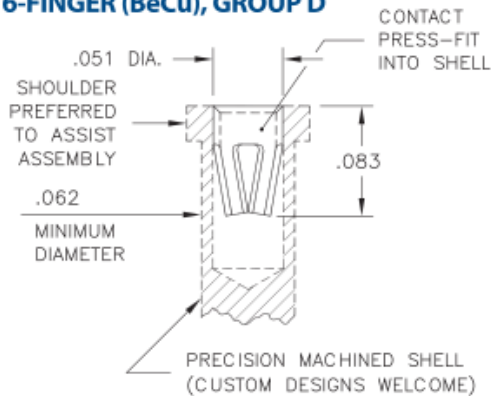

The insertion / extraction force characteristics above were derived using a 30 microinch gold-plated contact and polished steel gauge pins having a bullet-shaped tip. The curves represent typical average values; they are best used to compare the differences between similar size contacts and to guide you in selecting one that is suitable for your application. Your results may vary, so for your specification, we encourage you to obtain complimentary samples for your evaluation.

Material	Beryllium Copper	Current Rating (amps)	4.50
Fingers	6	Compliance	0.011
Length	.080" (2,032mm)	Contact Group	D

## ADDITIONAL NOTES AND SPECIFICATIONS

In the interest of improved design, quality and performance , Mill-Max reserves the right to make changes in its specifications without prior notice. Specifications and tolerances are provided wherever possible. The tolerance on dimensions of critical to function features is typically held tighter than the stated standard tolerances, such as press-fits, holes and lengths affecting the coplanarity of SMT products. Due to the wide variety of interconnects Mill-Max offers, the specific tolerances vary from product to product. If you need information regarding the tolerance of a particular part, please contact Technical Services.

## RELATED LINKS AND DOCUMENTS

Engineering Notebook: ( <https://www.mill-max.com/engineering-notebooks/machined-pin-pcb-connectors-interconnects> )

Environmental Compliance: ( <https://www.mill-max.com/rohs> )