

Product Specification

Number: L-KLS5-18650-L150
Name: 1x 18650 Li-ion cell Holder
Specification: _____
Customer: D16
Date: 2020-06-23

Customer Signature:



NINGBO KLS ELECTRONIC CO; LTD

Tel : 0086-574-86828566

Fax : 0086-574-86824882

ADD : NO. 8-1, RONGXIA RD. XIAPU SHANQIAN
INDUSTRIAL ZONE BEILUN NINGBO ZHEJIANG.

Compile	Check	Review	Approval
Jenny	Jack.C		

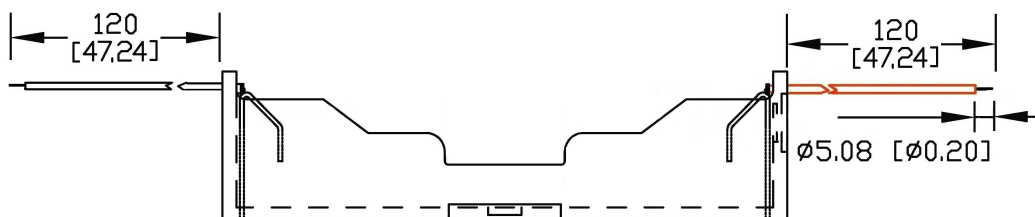
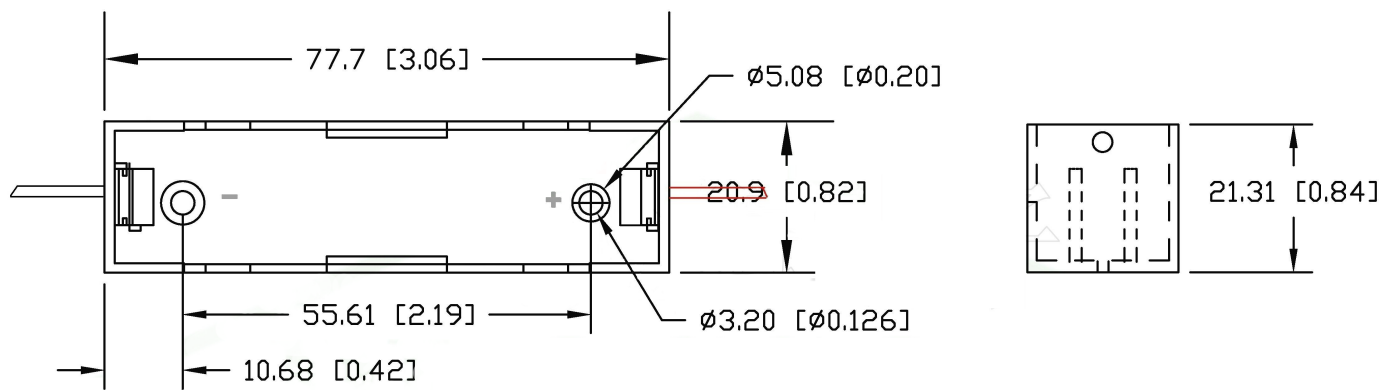

Dimensions:mm(In.)

SPECIFICATIONS	
Wire:	UL1007 AWG#22 Wire Leads
Black & Red:	120mm±5mm
Strip & Tin:	5mm±1mm
Material:	ABS. Resin,Black Color
Spring:	304 Stainless Steel Spring Temper,Nickel Plated
RoHS Compliant	



NINGBO KLS ELECTRONIC CO; LTD

Tel : 0086-574-86828566

Fax : 0086-574-86824882

ADD : NO. 8-1, RONGXIA RD. XIAPU SHANQIAN
INDUSTRIAL ZONE BEILUN NINGBO ZHEJIANG.