



4-Pin DC Power Cord

User Guide

Revision history—90001246

Revision	Date	Description
A	March 2011	Initial release.
B	October, 2012	Added a section on general purpose input/output commands.
C	July, 2017	Updated branding and made minor enhancements.

Trademarks and copyright

Digi, Digi International, and the Digi logo are trademarks or registered trademarks in the United States and other countries worldwide. All other trademarks mentioned in this document are the property of their respective owners.

© 2017 Digi International Inc. All rights reserved.

Disclaimers

Information in this document is subject to change without notice and does not represent a commitment on the part of Digi International. Digi provides this document “as is,” without warranty of any kind, expressed or implied, including, but not limited to, the implied warranties of fitness or merchantability for a particular purpose. Digi may make improvements and/or changes in this manual or in the product(s) and/or the program(s) described in this manual at any time.

Warranty

To view product warranty information, go to the following website:

www.digi.com/howtobuy/terms

Send comments

Documentation feedback: To provide feedback on this document, send your comments to techcomm@digi.com.

Customer support

Digi Technical Support: Digi offers multiple technical support plans and service packages to help our customers get the most out of their Digi product. For information on Technical Support plans and pricing, contact us at +1 952.912.3444 or visit us at www.digi.com/support.

Contents

4-Pin DC Power Cord

Pin-out diagram	4
Wiring configuration	5
Software configuration	6

Specifications

Power cord	7
Input signal	7
Output signal	7
Suggested minimum Relay Coil resistances:	7

4-Pin DC Power Cord

The 4-Pin DC Power Cord provides basic DC power input with the addition of two programmable signal lines. One of the signals lines is an input line, while the other can be configured as either an input or output line.

Pin-out diagram

The pin-out diagram for the 4-pin molded connector is shown here:

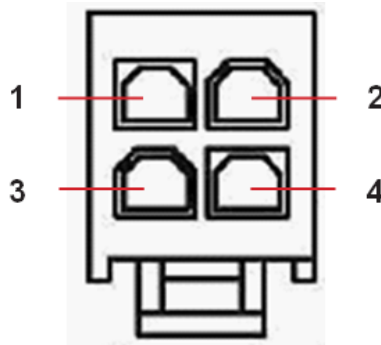

Pin	Wire Color	Signal
1	Black	Gnd
2	Blue	Input
3	Green	Input/Output
4	Red	Power

Wiring configuration



WARNING! Only one of the power connectors should be used. Never apply power to both the MAIN and AUX connectors at the same time.

The following figures illustrate typical wiring configurations for both input and output applications.

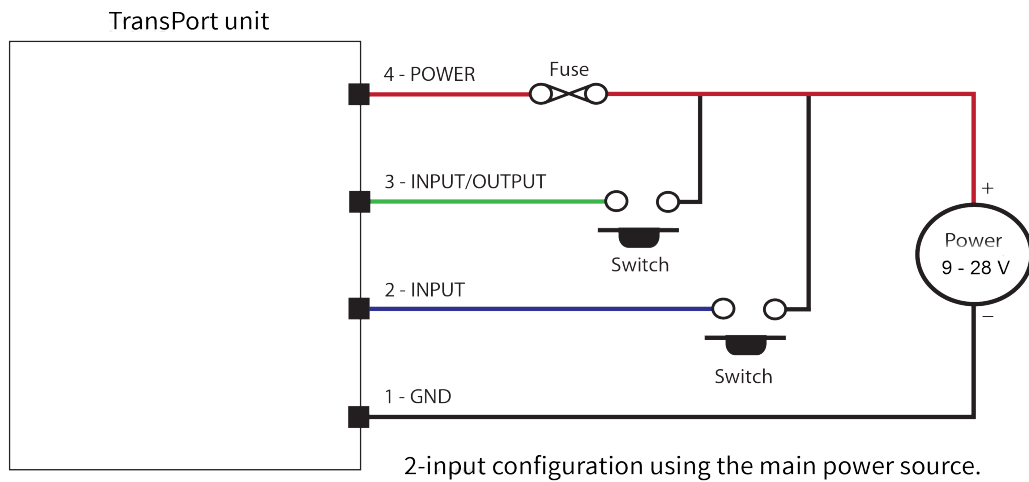

The supply voltage is limited by the maximum allowed 28 V of the inputs.

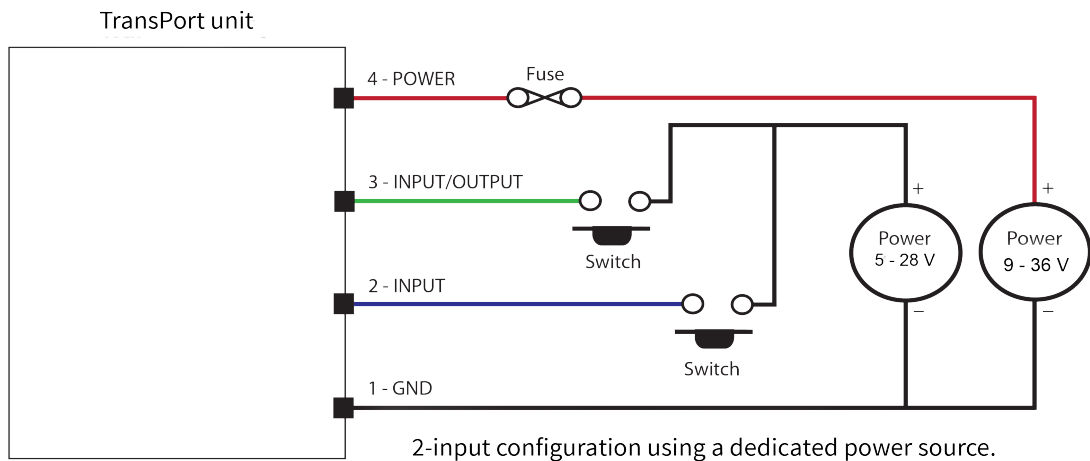

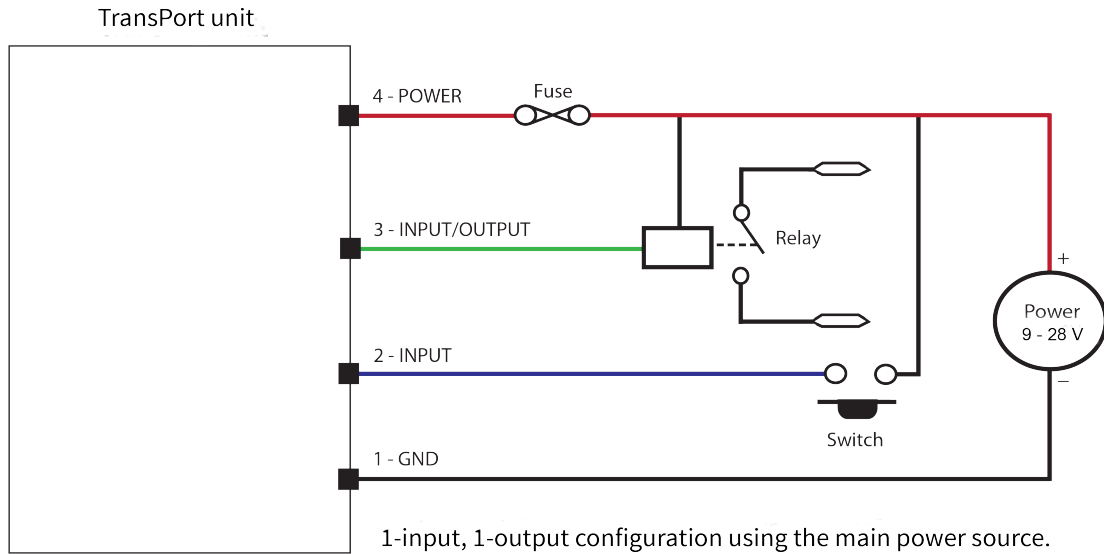

The supply voltage is limited by the maximum allowed 28 V or the I/O lines.

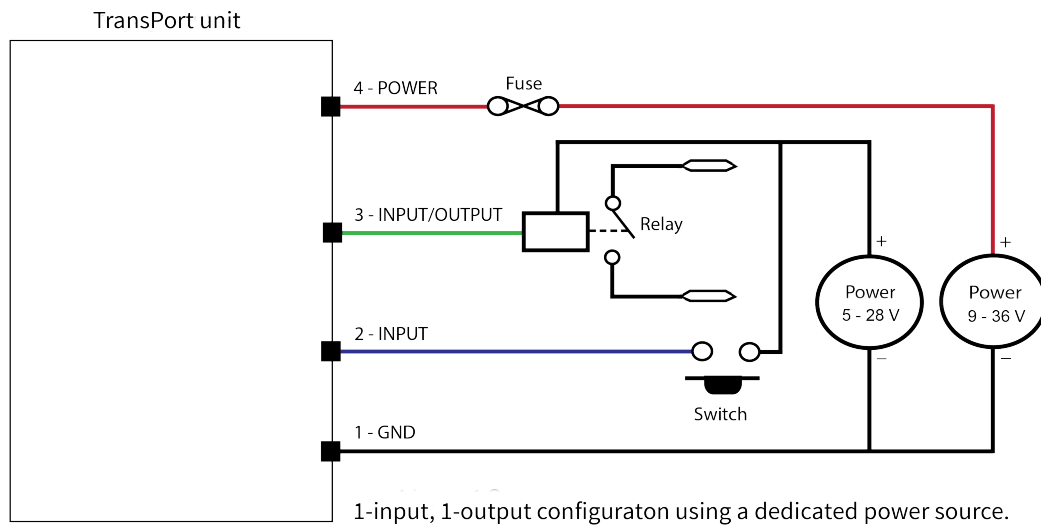

Software configuration

The mode of operation of the input/output line is configured via CLI commands. These commands can be built into Python or basic scripts to automate functionality, or, entered manually via the CLI or SMS. For more information, please see the *Digi TransPort WR User Guide*, part number 90001019, on www.digi.com/resources/documentation/DigiDocs/PDFs/90001019.pdf

Specifications

The following section outlines the specifications and configuration of the 4-Pin DC Power Cord.

Power cord

Replacement/additional power cords can be purchased directly from Digi. The part number for the replacement cord is:

Part number	Type	Length	Fuse
76000774	4-pin DC Power Cord for TransPort WR44	4 meter	3.15 A, 250 V, slow blow

Input signal

Applied input voltage to activate	+5 V to 28 V DC
Applied input voltage to deactivate	0 V to +1 V DC (Negative voltages can be applied to -28 V DC)
Maximum input current	3 mA

Input protection activates at more than +/-28 V DC. External current limiting is needed to protect input voltages above +/-28 V DC.

Output signal

Maximum voltage switched	+28 V DC
Maximum current switched	+40 mA
Maximum input current	3 mA

Output protection activates at more than +/-28 V DC. External current limiting is needed to protect input voltages above +/-28 V DC.

Output leakage current is equivalent to a 10 K ohms resistor to Ground.

Suggested minimum Relay Coil resistances:

Supply voltage	Minimum resistance
6 V DC	100 Ohms

Supply voltage	Minimum resistance
12 V DC	240 Ohms
24 V DC	480 Ohms

The output switch is protected against back-EMFs generated at relay turn-off.

Mouser Electronics

Authorized Distributor

Click to View Pricing, Inventory, Delivery & Lifecycle Information:

DIGI:

[76000774](#)