

# Board Level Cooling – Slide On 5740



## BOARD LEVEL COOLING - Slide On 5740

Slide On 5740 is a series of slide on board level heat sinks designed to cool TO-220, and TO-220-single gauge (0.020") devices. Representative Image Only

## ORDERING INFORMATION

Part Number	Device Type
574402B03200G	TO-220, TO-220-single gauge
574502B00000G	TO-220
574502B03200G	TO-220
574502B03300G	TO-220
574502B03700G	TO-220
574602B00000G	TO-220
574602B03300G	TO-220
574602B03700G	TO-220
574902B00000G	TO-220, TO-220-single gauge
574902B03300G	TO-220, TO-220-single gauge
574902B03700G	TO-220, TO-220-single gauge
574902B04300G	TO-220, TO-220-single gauge
578902B03200G	TO-220, TO-220-single gauge



## HEAT SINK DETAILS

Property	Details
Material	Aluminum
Finish	Black Anodize
Device Attachment Options	Spring Action Slide On
Thermal Interface Material	-

Property	Details
Heat Sink Width (mm)	21.84
Heat Sink Length (mm)	9.02
Heat Sink Mounting Direction	Horizontal, Vertical

## MECHANICAL & PERFORMANCE

Drawing dimensions are shown in mm, (in)

Part Number	Heat Sink Height	"X" Dim	"Y" Dim	"Z" Dim
574402B03200G	19.05	10.54 (0.415)	3.05 (0.120)	1.91 (0.075)
574502B00000G	19.05	-	-	-
574502B03200G	19.05	10.54 (0.415)	4.06 (0.160)	1.91 (0.075)
574502B03300G	19.05	10.54 (0.415)	4.06 (0.160)	1.91 (0.075)
574502B03700G	19.05	10.54 (0.415)	4.06 (0.160)	1.91 (0.075)
574602B00000G	17.53	-	-	-
574602B03300G	17.53	10.54 (0.415)	4.06 (0.160)	1.91 (0.075)
574602B03700G	17.53	10.54 (0.415)	4.06 (0.160)	1.63 (0.064)
574902B00000G	34.93	-	-	-
574902B03300G	34.93	10.54 (0.415)	3.05 (0.120)	1.91 (0.075)
574902B03700G	34.93	10.54 (0.415)	4.06 (0.160)	1.91 (0.075)
574902B04300G	34.93	10.54 (0.415)	4.06 (0.160)	1.63 (0.064)
578902B03200G	34.93	12.07 (0.475)	8.89 (0.350)	3.10 (0.122)

# Board Level Cooling – Slide On 5740

Part Number: 574402B03200G

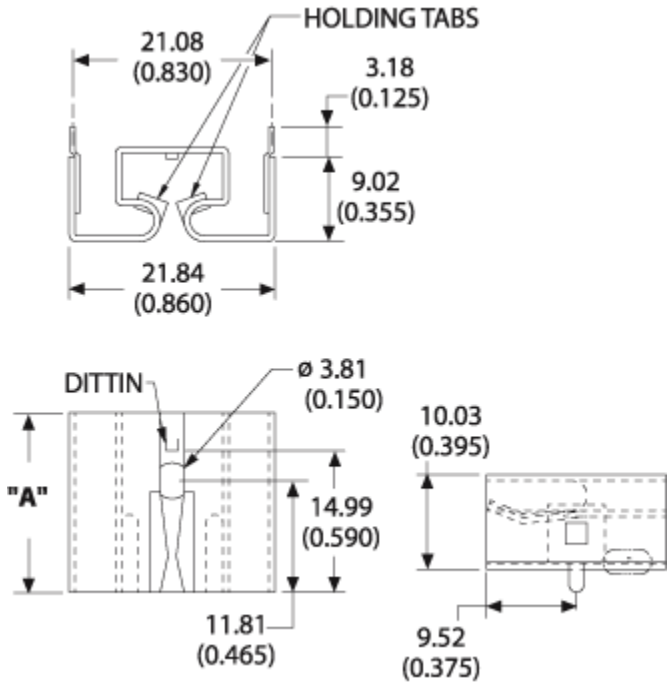

Mounting Details:

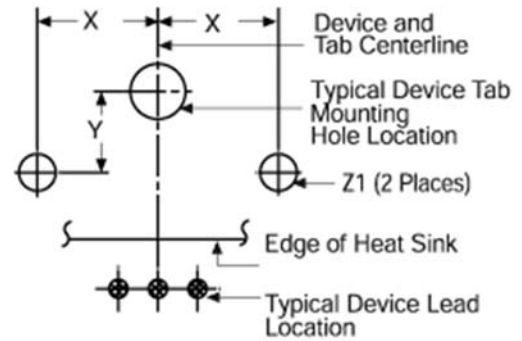

Part Number: 574502B00000G

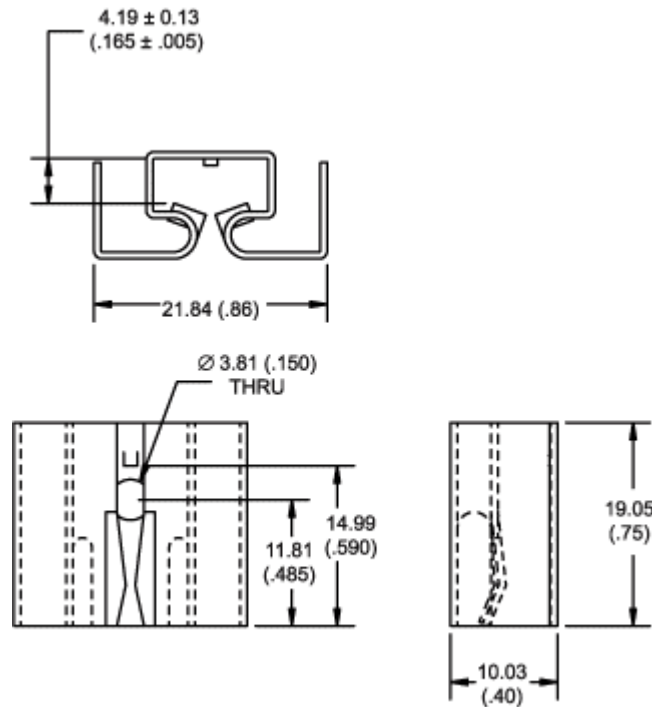

4.19 (.165) ± .005

Part Number: 574502B03200G

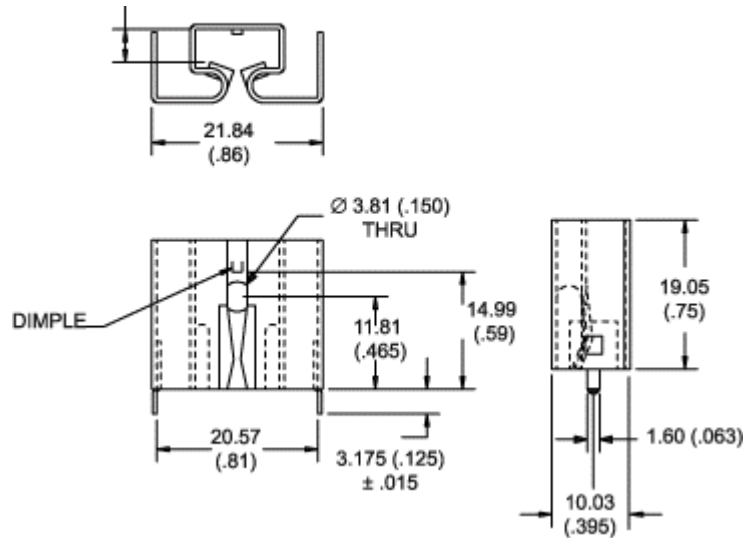

Mounting Details:

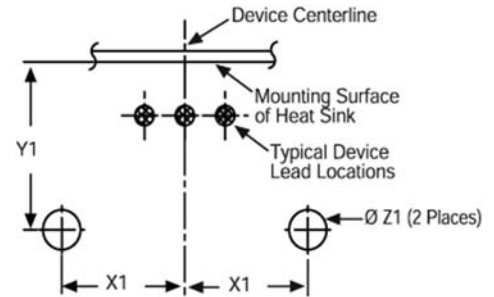

Part Number: 574502B03300G

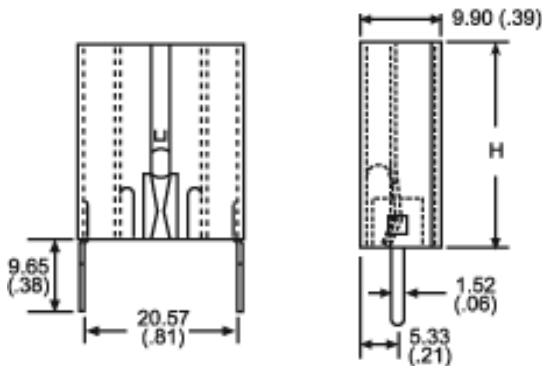

Mounting Details:

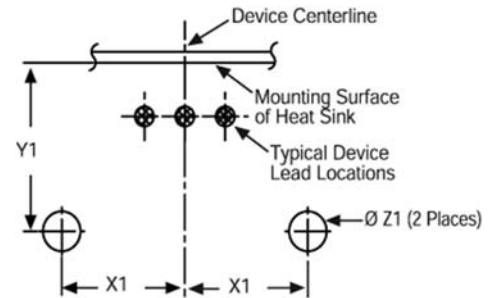

Part Number: 574502B03700G

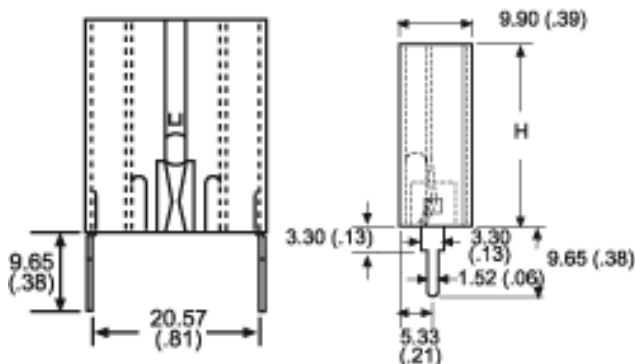

Mounting Details:

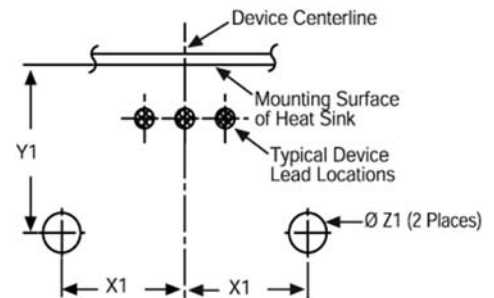

# Board Level Cooling – Slide On 5740

Part Number: 574602B00000G

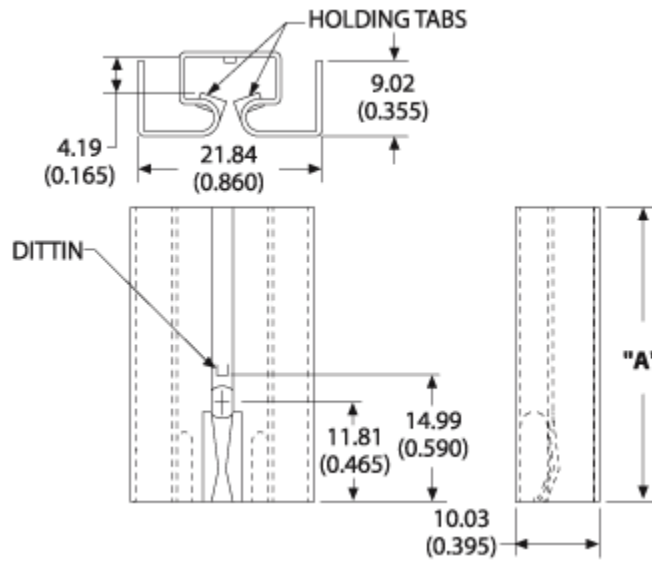

Part Number: 574602B03300G

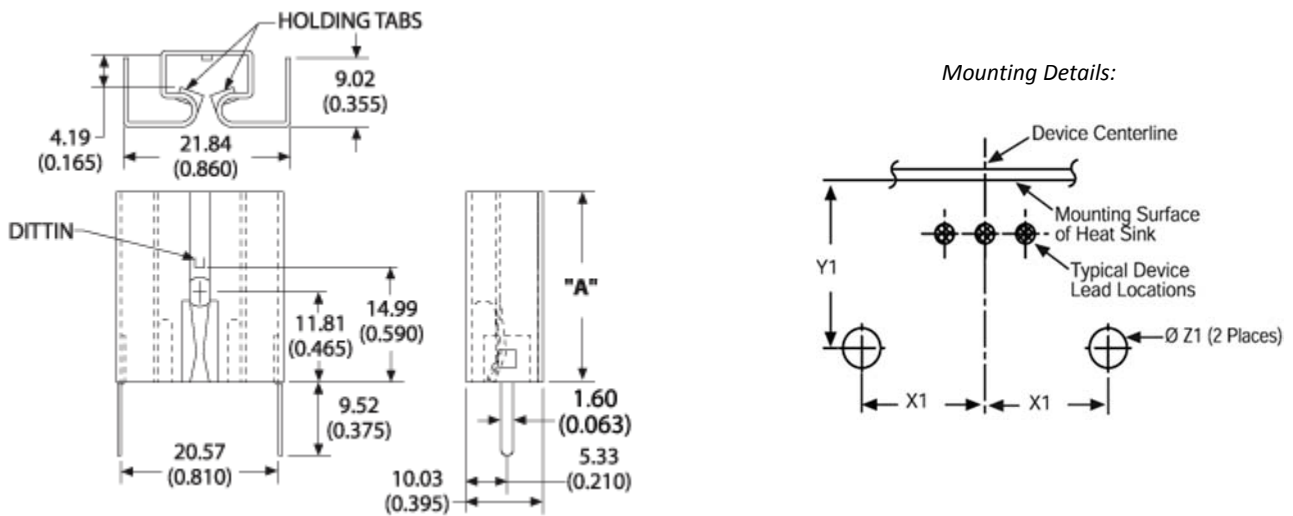

# Board Level Cooling – Slide On 5740

Part Number: 574602B03700G

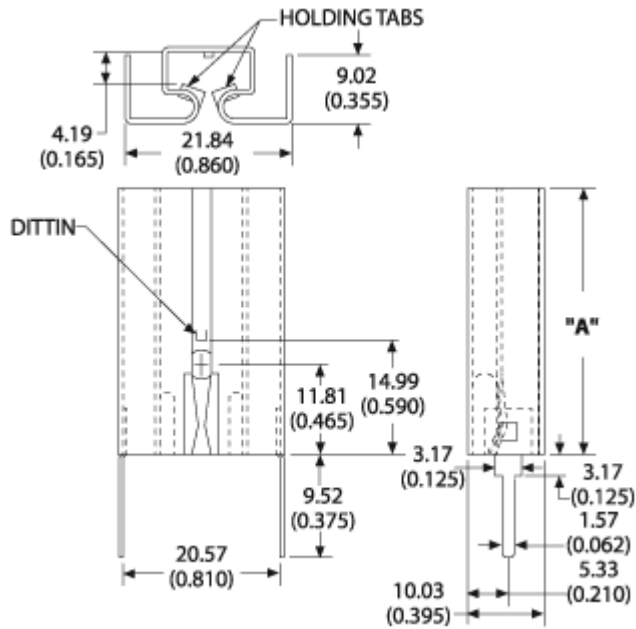

*Mounting Details:*

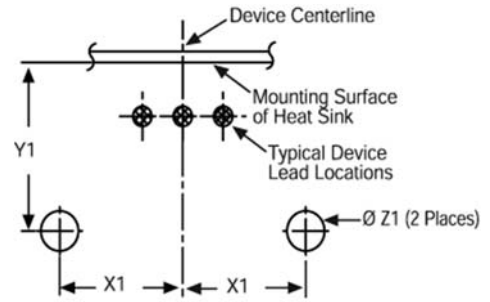

Part Number: 578902B03200G

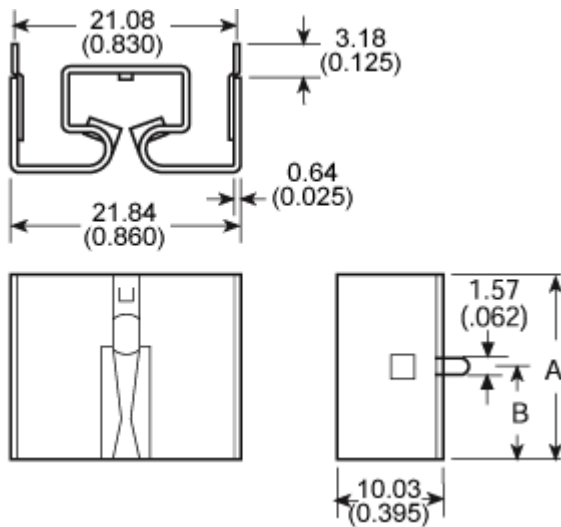

*Mounting Details:*

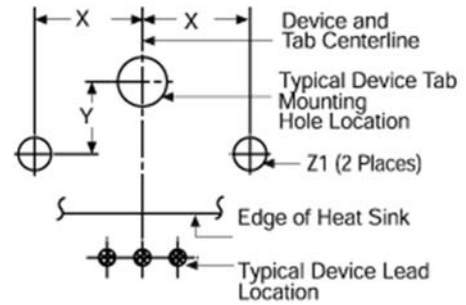

# Board Level Cooling – Slide On 5740

Part Number: 574902B00000G

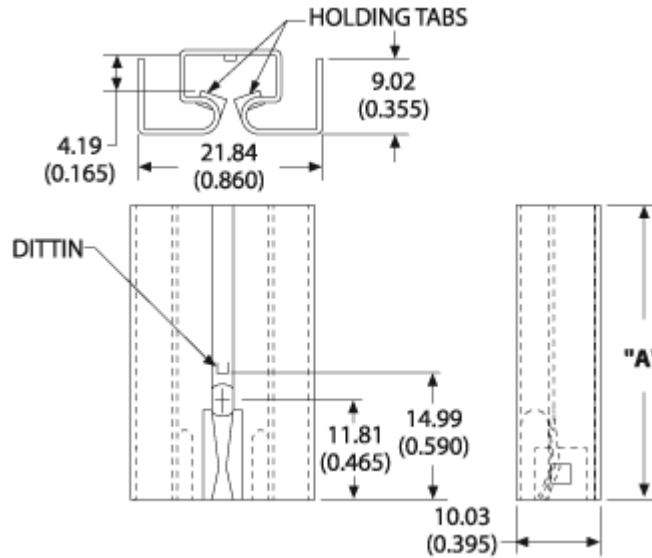

Part Number: 574902B03300G

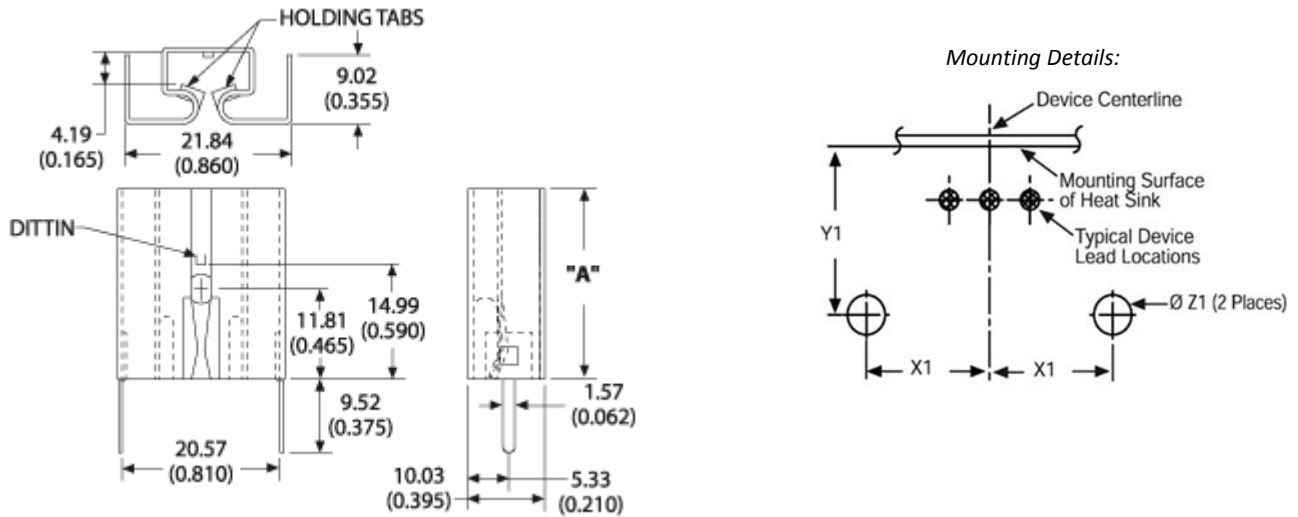

# Board Level Cooling – Slide On 5740

Part Number: 574902B03700G

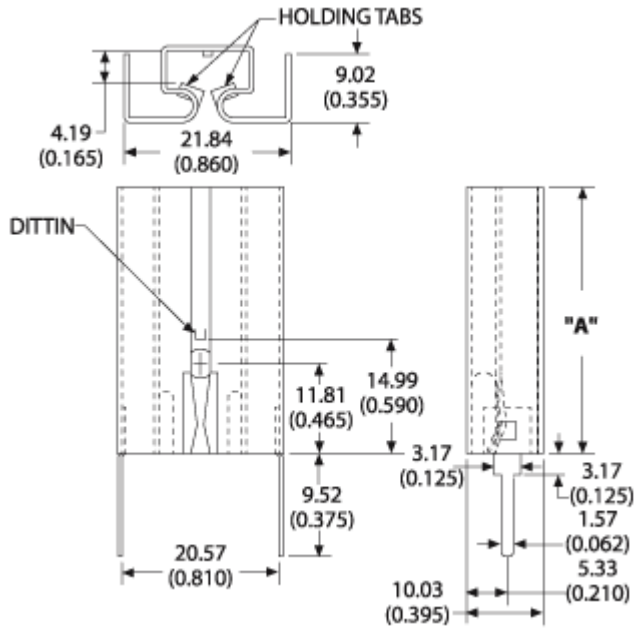

*Mounting Details:*

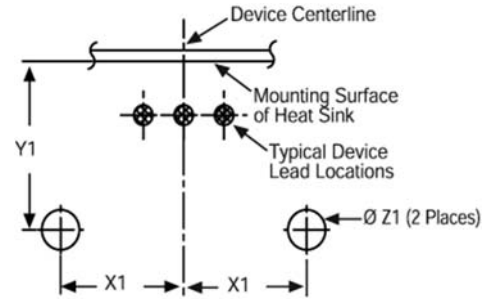

Part Number: 574902B04300G

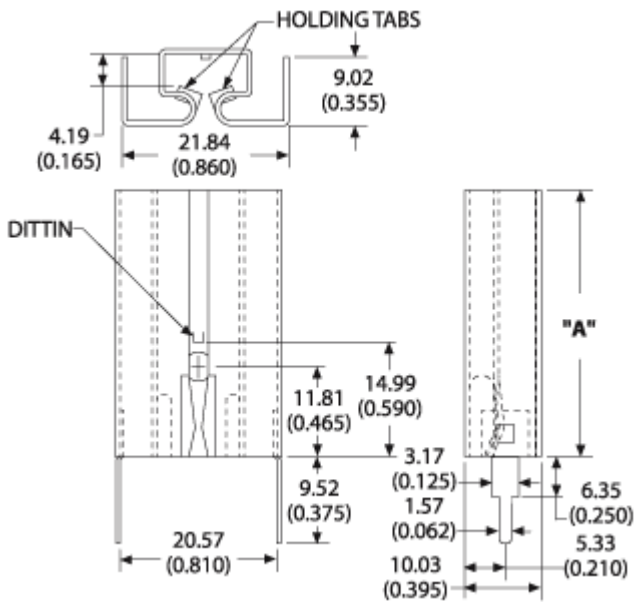

*Mounting Details:*

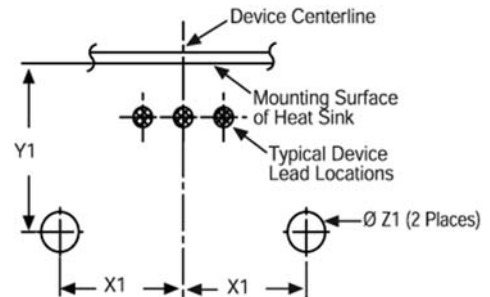

# Board Level Cooling – Slide On 5740

