

Vacuum Unit

Ejector System

Vacuum Pump System



Air supply is cut-off when vacuum is reached.

Energy saving ejector

Air consumption

93 % reduction

Reduced by the pressure switch for vacuum with energy saving function and efficient ejectors

(Under SMC's measurement conditions)



More efficient ejector

Suction flow (Compared to other SMC 1-stage ejectors)

50 % increase

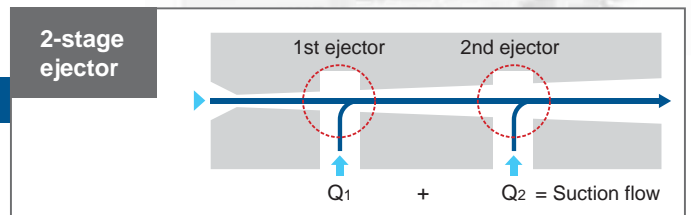

Wiring variations

D-sub connector



Flat ribbon cable connector



Individual wiring

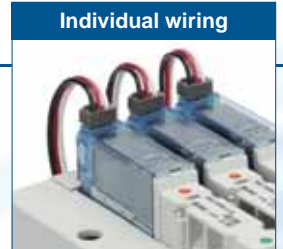

ZK2□A Series



CAT.EUS100-129B-UK

Energy Saving Ejector

Digital pressure switch with energy saving function

reduces air consumption by **90 %**.^{*1}

^{*1} Under SMC's measurement conditions

While the suction signal is ON, the ON/OFF operation of the supply valve is also performed automatically within the set value.

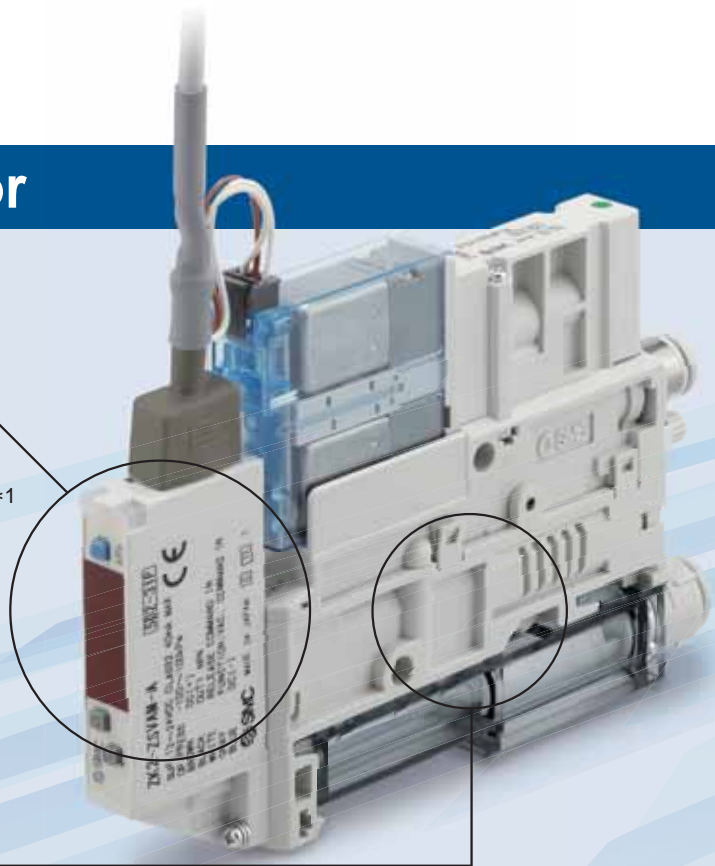

More efficient ejector

Air consumption **30 % reduction**

(Compared to other SMC 1-stage ejectors)

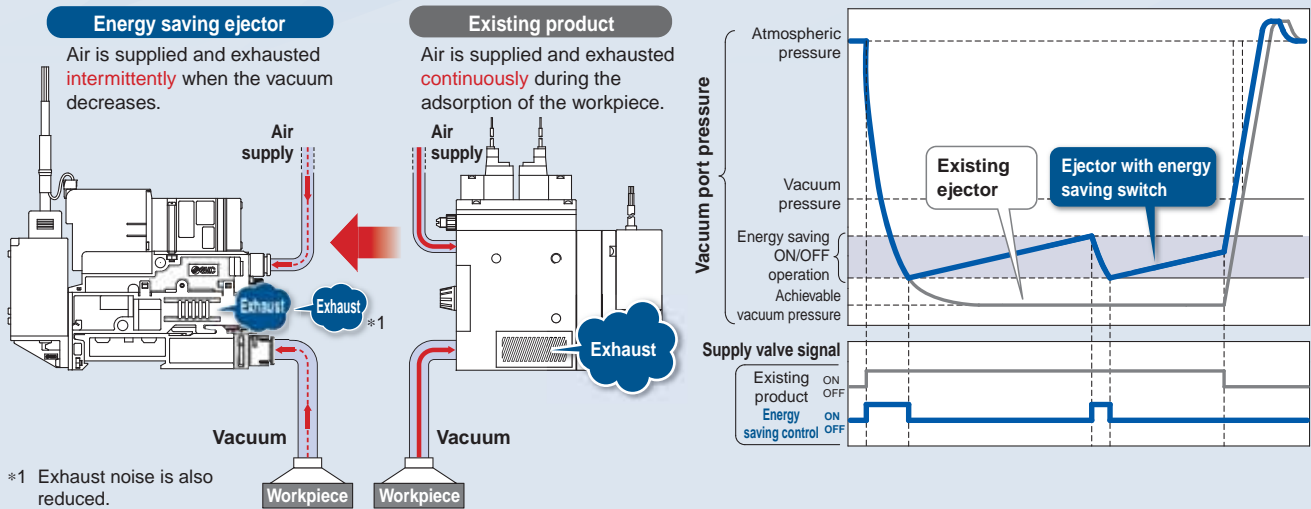

Energy saving efficiency: **93 % reduction**

Power consumption cost per year reduced by

109 €/year^{*1}

The energy saving function shortens the exhaust time, which reduces the annual power consumption cost.

With energy saving function
More efficient ejector

	Power consumption cost per year	Annual air consumption	Exhaust time	Air consumption
ZK2/With energy saving function	8 €/year	638 m ³ /year	0.6 s	58 l/min (ANR)
Existing product	117 €/year	9,350 m ³ /year	6 s	85 l/min (ANR)

^{*1} **Cost conditions** · Air unit 0.012 €/m³ (ANR), Annual operating cycles: 1100000 (Operating hours: 10 hours/day, Operating days: 250 days/year, 450 cycles/h, when 1 unit is used)

High-noise Reduction Silencer

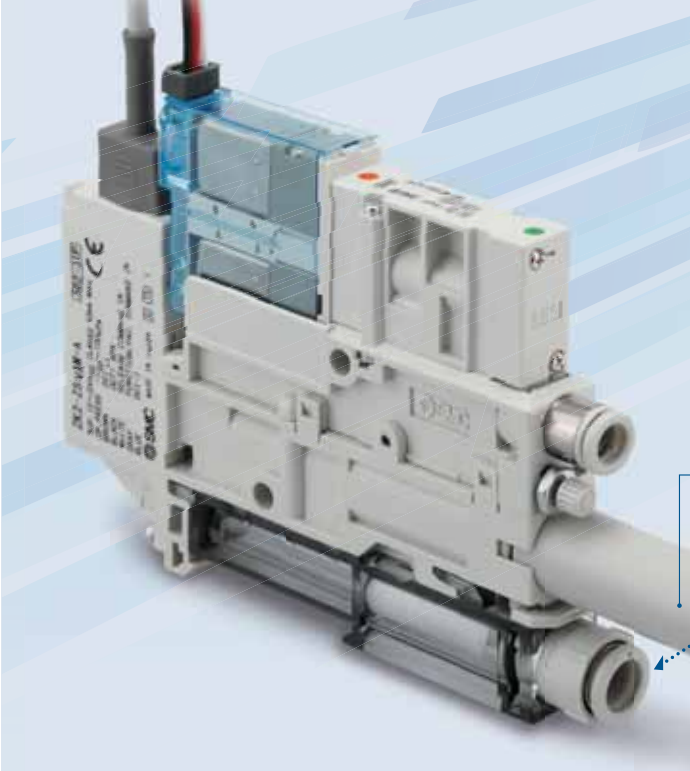

Improved low noise and suction flow by adoption of a high-noise reduction silencer

High-noise reduction silencer
 Unpleasant frequencies are removed while maximising vacuum performance by using a dedicated silencer with better silencing effect.

Low noise

46 dB (A)*1

*1 Nozzle size: Ø 0.7 (Under SMC's measurement conditions)

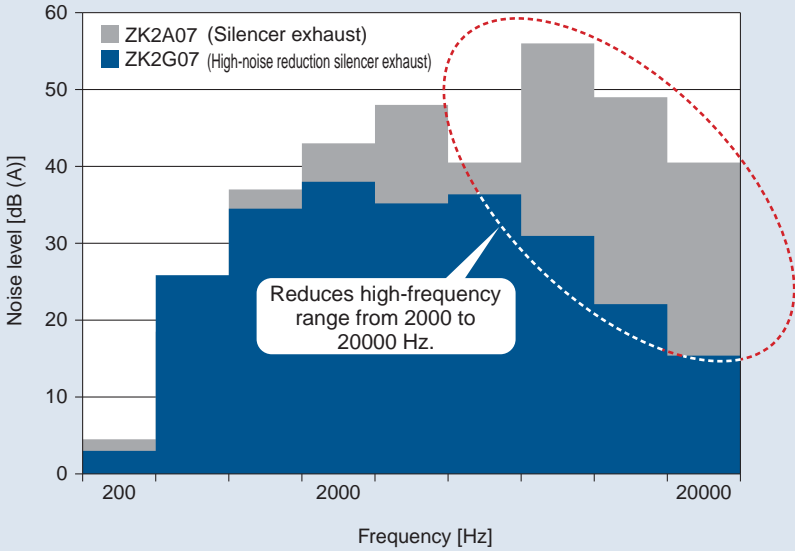

Suction flow

Improved by up to approx. **20 %**

Nozzle size	Exhaust type	Max. suction flow [l/min (ANR)]	
		40	80
Ø 1.5	High-noise reduction silencer exhaust	67	83
	Silencer exhaust	67	67

Approx. 20% increase in suction flow for the high-noise reduction silencer exhaust at 80 ANR.

All-in-one Piping Wiring Installation time reduced!!

Dual 2-port valve (Supply valve/Release valve)

Supply valve: Self-holding*1

Even if there is a power cut, the vacuum is maintained as long as there is supply air.

- ① The vacuum is maintained during power failure as long as air is supplied.
This can prevent the workpiece from being dropped.
- ② The unit turns on by instantaneous energising (minimum 20 ms.). Continuous energising is not necessary.
This can reduce the power consumption.

Linked supply and release valves operation*1

The self-holding type supply valve will be turned off by turning on the release valve.
It is not necessary to send a signal to stop the vacuum, which simplifies the wiring and programming.
(Existing double solenoid and latching type require a signal to stop the vacuum.)

Power saving pilot valve

Supply and release valve are low-power consumption model. **(0.4 W)**

*1 When the self-holding and release valve linked (valve type R) is selected

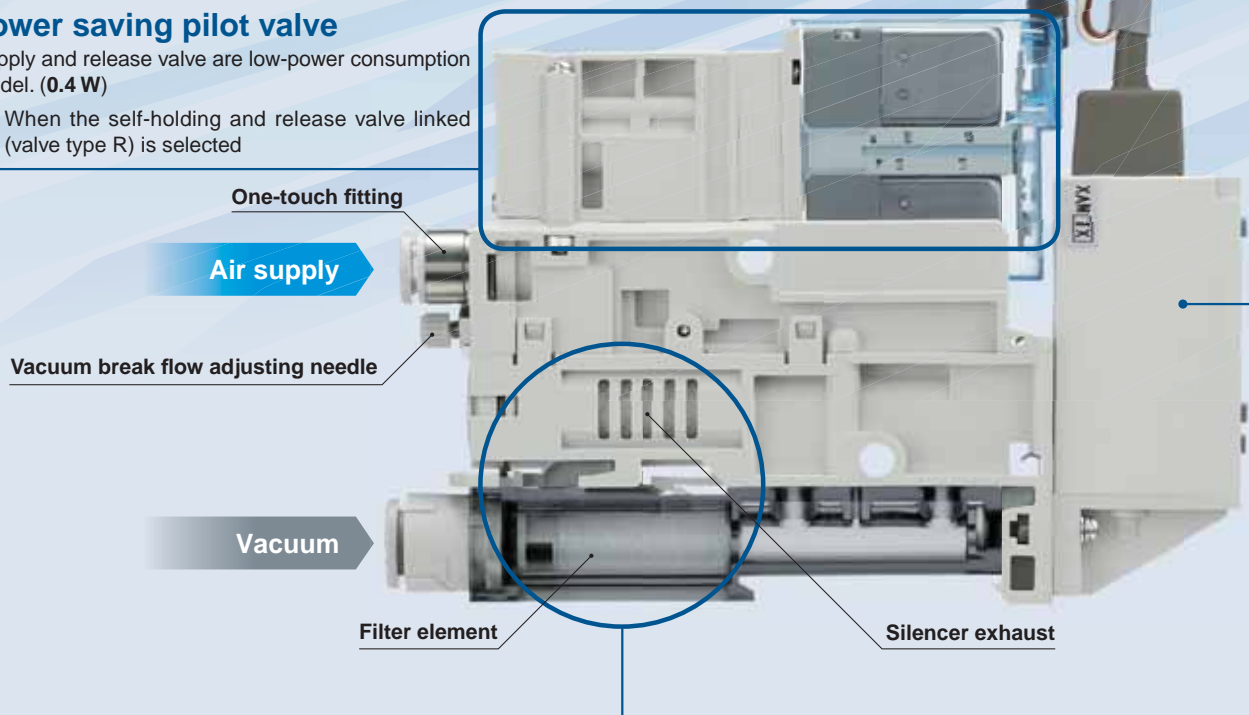

Easier maintenance No tools are required for replacement.

Replacement of filter element

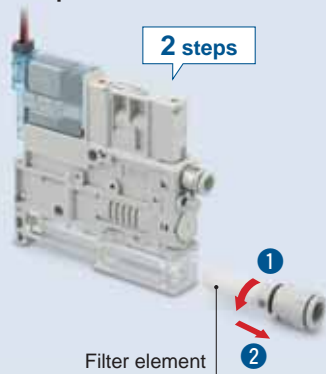

Transparent filter case allows visual check of the contamination.
If there is dirt inside the case, it is possible to remove the case and clean it.

Replacement of filter case

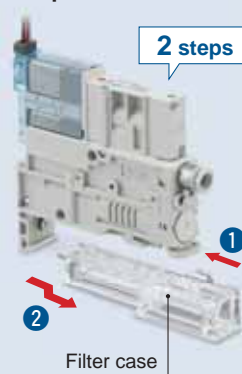

Replacement of sound absorbing material

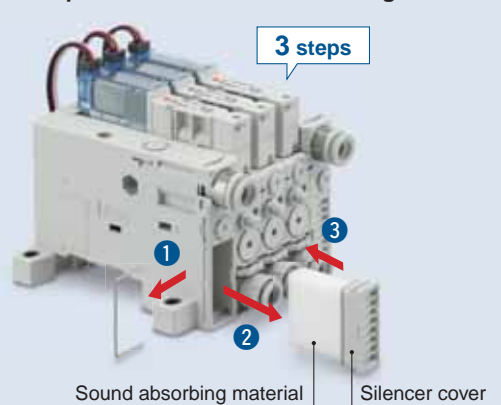

The sound absorbing material can be installed/removed without using screws.

Pressure Sensor/Switch Variations



■ Pressure switch for vacuum with energy saving function



■ Pressure switch for vacuum



■ Pressure sensor

Pressure switch for vacuum Set value copy function*1

Reduction in setting work/Prevention of mistakes in setting



Source of copy



1 unit



2 units



10 units

Set value can be copied up to 10 units.

*1 Copy function is not available for switches with the pressure switch for vacuum with energy saving function.

Mounting (Options)

■ Single unit bracket mounting



Mounting bracket for single unit

■ Single unit DIN rail mounting

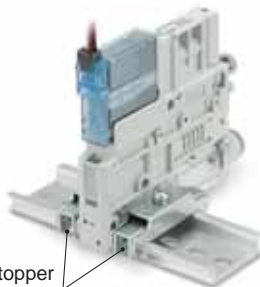

Stopper

■ Manifold DIN rail mounting



DIN rail mounting bracket

Vacuum Unit Variations

Single Unit Variations

Ejector System

Nozzle size

Ø 0.7, Ø 1.0, Ø 1.2, Ø 1.5

Air pressure supply (PV) port

Ø 6, Ø 1/4" One-touch fittings

Vacuum break flow adjusting needle

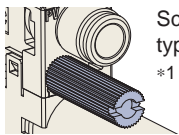

Screwdriver operation type long lock nut*1
*1 Option

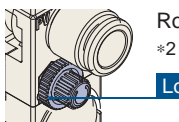

Round lock nut*2
*2 Option
Lock nut

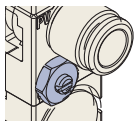

Screwdriver operation type*3
*3 Option

Vacuum (V) port

Ø 6, Ø 8 One-touch fittings
Ø 1/4", Ø 5/16" One-touch fittings

Supply valve/Release valve: Rated voltage

12, 24 VDC

Vacuum switch

- Pressure sensor
- Pressure switch for vacuum
- Pressure switch for vacuum with energy saving function

Without vacuum switch



Combination of supply valve and release valve

Supply valve	Release valve
N.C	N.C
N.C	None
Self-holding release valve linked	N.C
None	None

Silencer exhaust

Exhaust (EXH) port

Port exhaust High-noise reduction silencer exhaust

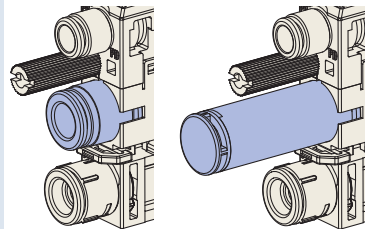

With individual release pressure supply (PD) port*1

*1 Option

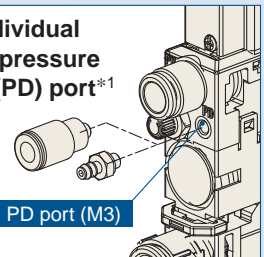

PD port (M3)

Vacuum Pump System

Vacuum pressure supply (PV) port

Ø 6, Ø 1/4" One-touch fittings

Pilot pressure supply (PS) port

Ø 4, Ø 5/16" One-touch fittings

Vacuum (V) port

Ø 6, Ø 8 One-touch fittings
Ø 1/4", Ø 5/16" One-touch fittings

Vacuum pump system PE port female thread specification*1

*1 Option

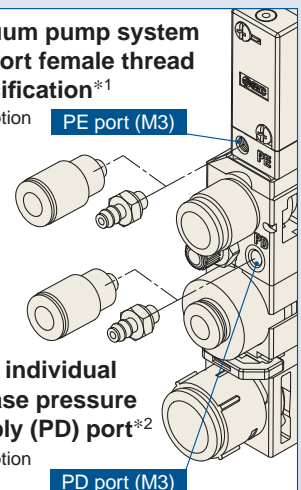

PE port (M3)

With individual release pressure supply (PD) port*2

*2 Option

PD port (M3)

Manifold Variations

Ejector System

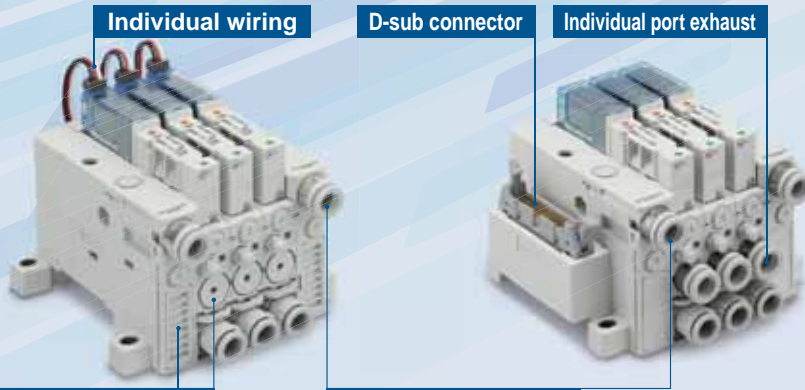

Complex exhaust*1

*1 The complex exhaust is a combined exhaust method of the common exhaust from the end plate and the direct exhaust from each station.

Common air pressure supply (PV) port



*2 Option

Manifold stations

1 to 10 stations

Wiring type

- D-sub connector
- Flat ribbon cable connector
- Individual wiring

Exhaust type*3

- Complex exhaust*1
- Port exhaust
- High-noise reduction silencer exhaust

*3 When the ejector system is selected

**Air pressure supply (PV) port
Ø 8, Ø 5/16"**

- Common supply
- Individual supply*4

*4 Option

Vacuum Pump System

Common pilot pressure supply (PS) port



Flat ribbon cable connector

Common vacuum pressure supply (PV) port

**Vacuum pressure (PV) port
Ø 8, Ø 5/16"**

- Common supply

Model Selection Guide for the Vacuum Unit ZK2□A Series

		Valve			Switch and Sensor		How to order	
		With valve		Without	Without energy saving function	With energy saving function		
		Supply valve	Release valve		Pressure sensor/Pressure switch for vacuum	Pressure switch for vacuum		
Ejector System	Single unit	With valve Pressure switch for vacuum			●	—	p. 9	
		With valve Pressure switch for vacuum with energy saving function			●	—		
		Without valve Pressure switch for vacuum			—	●		—
	For Manifold	With valve Pressure switch for vacuum			●	—	p. 11	
		With valve Pressure switch for vacuum with energy saving function			●	—		
		Without valve Pressure switch for vacuum			—	●		—
	Manifold		Manifold	—	—	—	—	p. 13
				—	—	●	—	
	Vacuum Pump System	Single unit	With valve Pressure sensor			●	—	p. 15
With valve Pressure sensor					●	—		
Without valve Pressure sensor					—	●	—	
For Manifold		With valve Pressure sensor			●	—	p. 16	
		With valve Pressure sensor			●	—		
		Without valve Pressure sensor			—	●		—
Manifold			Manifold	—	—	—	—	p. 17
				—	—	—	—	

CONTENTS

Vacuum Unit ZK2□A Series

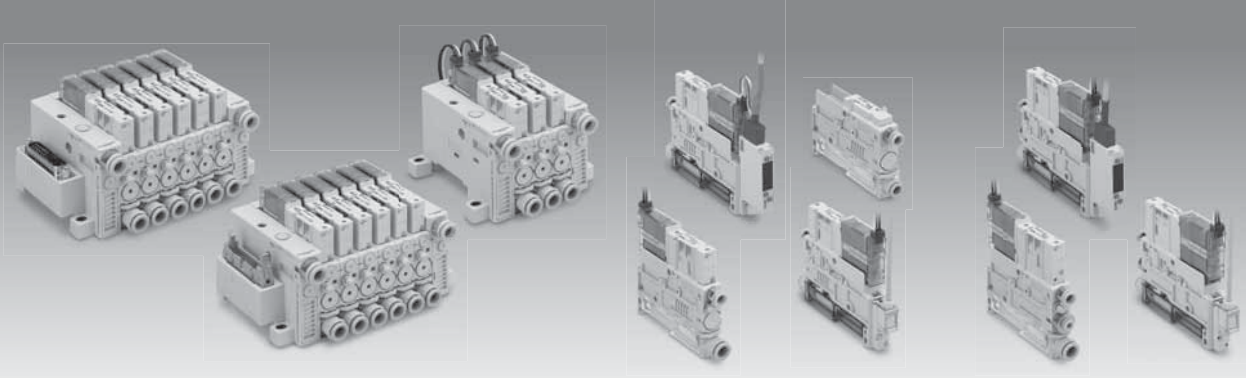

● Ejector System

Single Unit Ejector + With Valve + Without Energy Saving Function	p. 9
Single Unit Ejector + With Valve + With Energy Saving Function	p. 10
For Manifold Ejector + With Valve + Without Energy Saving Function	p. 11
For Manifold Ejector + With Valve + With Energy Saving Function	p. 12
Single Unit For Manifold Ejector + Without Valve + Without Energy Saving Function	p. 13
Manifold	p. 14

● Vacuum Pump System

Single Unit Vacuum Pump System + With Valve + Without Energy Saving Function	p. 15
For Manifold Vacuum Pump System + With Valve + Without Energy Saving Function	p. 16
Manifold	p. 17

Specifications, Weight	p. 18
Ejector Exhaust Characteristics/Flow Rate Characteristics	p. 19
Vacuum Pump System Flow Rate Characteristics, Vacuum Release Flow Rate Characteristics, How to Read the Flow Rate Characteristics Graph	p. 21
Pressure Sensor/Pressure Switch for Vacuum Specifications, Description (Pressure Switch for Vacuum)	p. 22
Pressure Switch for Vacuum with Energy Saving Function Specifications, Internal Circuit and Wiring Example	p. 23
Port Layout	
Standard Products	p. 24
Option -D	p. 26
Option -L	p. 29
Construction	p. 31
Replacement Parts for Single Unit / How to Order	p. 32
Exploded View of Manifold	p. 33
Dimensions	p. 35
Electrical Wiring Specifications, Optional Specifications/Functions/Applications	p. 42

Specific Product Precautions	p. 44
Quality of Supply Air	p. 51

Ejector System Vacuum Unit

ZK2□A Series



Single Unit Ejector + With Valve + Without Energy Saving Function

How to Order

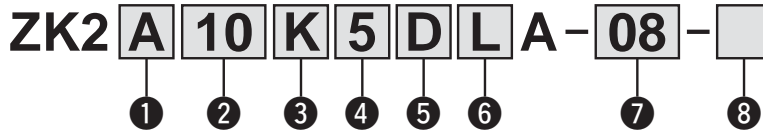

1 Body/Exhaust type

Symbol	Body	Exhaust type
A	Single unit	Silencer exhaust*1
		Port exhaust
B	Single unit	High-noise reduction silencer exhaust

*1 With exhaust port when 2 is 12 or 15

4 Rated voltage (Supply valve/Release valve)

Symbol	Voltage
5	24 VDC
6	12 VDC

5 Pressure switch for vacuum/Pressure sensor

Symbol	Type	Pressure range [kPa]	Specifications		
			NPN 2 outputs	PNP	With unit selection function*3
A	Pressure switch for vacuum	-101 to 0	●	—	●
B			●	—	None (SI unit only)
C			—	●	●
D			—	●	None (SI unit only)
E			●	—	●
F	Pressure sensor	-100 to 100	●	—	None (SI unit only)
H			—	●	●
J			—	●	None (SI unit only)
T			—	●	●
N	Without pressure switch for vacuum/pressure sensor		Analogue output 1 to 5 V		

*3 The unit for the type without the unit selection function is fixed as kPa.

7 Vacuum (V) port

Symbol	Vacuum (V) port
06	∅ 6
08	∅ 8
07	∅ 1/4"
09	∅ 5/16"

2 Nominal nozzle size

Symbol	Nominal nozzle size
07	∅ 0.7
10	∅ 1.0
12	∅ 1.2
15	∅ 1.5

* Refer to page 1 8 for the standard supply pressure per nozzle diameter.

3 Combination of supply valve and release valve

Symbol	Supply valve		Release valve
	N.C.	Self-holding	N.C.
K	●	—	●
J	●	—	—
R	—	●*2	●

*2 Supply valve maintains vacuum by energisation (20 ms or more). Stopping the vacuum turns on the release valve.

6 Connector (Supply valve/Release valve/Pressure switch for vacuum)

Symbol	For supply valve/ release valve: 300 mm (Connector assembly)*4	For pressure switch for vacuum: 2 m (Lead wire with connector)	Pressure sensor assembly: 3 m (With lead wire)	Note
L	●	—	●	Cannot be selected when 5 is N
L1	None	—	●	
L2	●	—	None	Cannot be selected when 5 is P or T
L3	None	—	None	

*4 For the connector length other than 300 mm, order the connector assembly on page 32 separately.

8 Option*5 (For details on the Function/Application, refer to page 42.)

Symbol	Type	Note
—	Without option	—
B	Mounting bracket for single unit (nuts and bolts are included) 	—
D	With individual release pressure supply (PD) port (M3)*6 	Cannot be selected when 3 is J
E	Vacuum break flow adjusting needle Screwdriver operation type long lock nut 	Cannot be selected when 3 is J
J	Round lock nut Lock nut 	Can be selected only for the combination of J and K
K	Screwdriver operation type Vacuum break flow adjusting needle 	
W	With exhaust interference prevention valve 	When J is selected for 8, install the release valve or vacuum breaker in the middle of the vacuum piping.

*5 When more than one option is selected, list the option symbols in alphabetical order. (Example -BJ)

*6 Use a One-touch fitting or barb fitting (M-3AU-4) for piping. (O.D.: Within ∅ 6.2)

Ejector System Vacuum Unit

ZK2□A Series



Single Unit Ejector + With Valve + With Energy Saving Function

How to Order

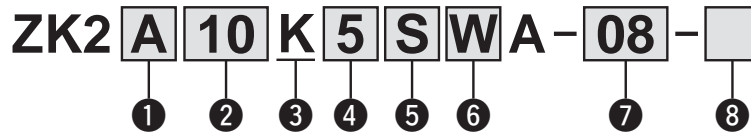

1 Body/Exhaust type

Symbol	Body	Exhaust type
A	Single unit	Silencer exhaust*1
		Port exhaust
G	Single unit	High-noise reduction silencer exhaust

*1 With exhaust port when 2 is 12 or 15

2 Nominal nozzle size

Symbol	Nominal nozzle size
07	Ø 0.7
10	Ø 1.0
12	Ø 1.2
15	Ø 1.5

* Refer to page 18 for the standard supply pressure per nozzle diameter.

3 Combination of supply valve and release valve

Symbol	Supply valve	Release valve
	K	N.C.

4 Rated voltage (Supply valve/Release valve)

Symbol	Voltage
5	24 VDC
6	12 VDC

5 Pressure switch for vacuum with energy saving function

Symbol	Pressure range [kPa]	Specifications		
		NPN	PNP	With unit selection function*2
K	-100 to 100	●	—	●
Q		●	—	None (SI unit only)
R		—	●	●
S		—	●	None (SI unit only)

*2. The unit for the type without the unit selection function is fixed as kPa.

6 Connector

Symbol	For pressure switch for vacuum with energy saving function: 2 m (Lead wire with connector)
W	●
L3	None

7 Vacuum (V) port

Symbol	Vacuum (V) port
06	Ø 6
08	Ø 8
07	Ø 1/4"
09	Ø 5/16"

8 Option*3 (For details on the Function/Application, refer to page 42.)

Symbol	Type	Note
—	Without option	—
B	Mounting bracket for single unit (nuts and bolts are included)	—
D	With individual release pressure supply (PD) port (M3)*4	—
E	Screwdriver operation type long lock nut	Can be selected only for the combination of J and K
J	Round lock nut	
K	Screwdriver operation type Vacuum break flow adjusting needle	

*3 When more than one option is selected, list the option symbols in alphabetical order. (Example -BJ)

*4 Use a One-touch fitting or barb fitting (M-3AU-4) for piping. (O.D.: Within Ø 6.2)

Ejector System Vacuum Unit

ZK2□A Series



For Manifold Ejector + With Valve + Without Energy Saving Function

Refer to page 14 for How to Order Manifold.

How to Order

ZK2 **C** **12** **K** **5** **D** **L** **A** - **08** - □

1 2 3 4 5 6 7 8

1 Body/Exhaust type

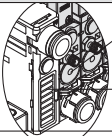
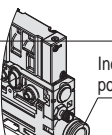
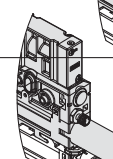
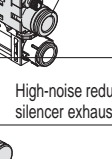
Symbol	Body	Exhaust type
C	For Manifold	Complex exhaust*1 
		Individual port exhaust 
F	For Manifold	High-noise reduction silencer exhaust 
H		High-noise reduction silencer exhaust 

*1 Combination of direct exhaust and end plate exhaust from each station

4 Rated voltage (Supply valve/Release valve)

Symbol	Voltage
5	24 VDC
6	12 VDC

5 Pressure switch for vacuum/Pressure sensor

Symbol	Type	Pressure range [kPa]	Specifications		
			NPN	PNP	With unit selection function*3
A	Pressure switch for vacuum	-101 to 0	●	—	●
B			●	—	None (SI unit only)
C			—	●	●
D		—	●	None (SI unit only)	
E		-100 to 100	●	—	●
F			●	—	None (SI unit only)
H	—		●	●	
J	—	—	●	None (SI unit only)	
P	Pressure sensor	-101 to 0	Analogue output 1 to 5 V		
T	Pressure sensor	-100 to 100	Analogue output 1 to 5 V		
N	Without pressure switch for vacuum/pressure sensor				

*3 The unit for the type without the unit selection function is fixed as kPa.

7 Vacuum (V) port

Symbol	Vacuum (V) port
06	∅ 6
08	∅ 8
07	∅ 1/4"
09	∅ 5/16"

2 Nominal nozzle size

Symbol	Nominal nozzle size
07	∅ 0.7
10	∅ 1.0
12	∅ 1.2
15	∅ 1.5

* Refer to page 18 for the standard supply pressure per nozzle diameter.

3 Combination of supply valve and release valve

Symbol	Supply valve		Release valve
	N.C.	Self-holding	N.C.
K	●	—	●
J	●	—	—
R	—	●*2	●

*2 Supply valve maintains vacuum by energisation (20 ms or more). Stopping the vacuum turns on the release valve.

6 Connector

(Supply valve/Release valve/Pressure switch for vacuum)

Symbol	For supply valve/release valve		For pressure switch for vacuum: 2 m (Lead wire with connector)	Pressure sensor assembly: 3 m (With lead wire)	Note
	Centralised wiring specification (Plug-in)	Individual wiring specification: 300 mm (Connector assembly)*4			
C	●	None	●	—	Cannot be selected when 5 is N
C1	●	None	—	—	Cannot be selected when 5 is P or T
L	None	●	—	●	Cannot be selected when 5 is N
L1	None	None	—	●	Cannot be selected when 5 is N
L2	None	●	—	None	Cannot be selected when 5 is P or T
L3	None	None	—	None	Cannot be selected when 5 is P or T

*4 For the connector length other than 300 mm, order the connector assembly on page 32 separately.

8 Option*5 (For details on the Function/Application, refer to page 42.)

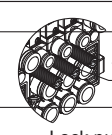
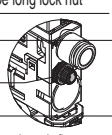
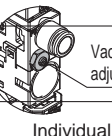
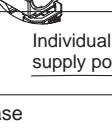
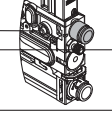
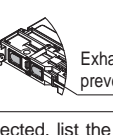
Symbol	Type	Note
—	Without option	—
E	Vacuum break flow adjusting needle	Screwdriver operation type long lock nut 
		Round lock nut 
		Screwdriver operation type 
J	Vacuum break flow adjusting needle	Cannot be selected when 3 is J Can be selected only for the combination of J and K
K	Vacuum break flow adjusting needle	—
L	Manifold individual supply specification*6 	—
P	With manifold common release pressure supply (PD) port 	Cannot be selected when 3 is J
W	With exhaust interference prevention valve 	When J is selected for 3, install the release valve or vacuum breaker in the middle of the vacuum piping.

*5 When more than one option is selected, list the option symbols in alphabetical order. (Example -EL)

*6 When F or H is selected for 1 and L is selected for the option, the space for adjusting the needle is reduced. Products which can be operated more easily can be specified by option E or K.

Ejector System Vacuum Unit

ZK2□A Series



For Manifold Ejector + With Valve + With Energy Saving Function

Refer to page 14 for How to Order Manifold.

How to Order

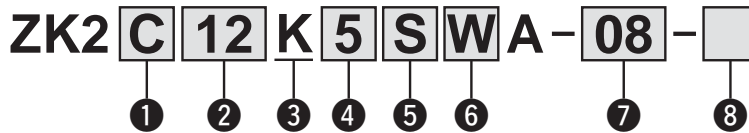

1 Body/Exhaust type

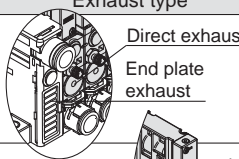
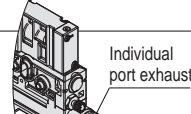
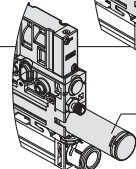
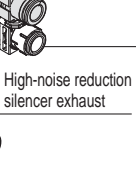
Symbol	Body	Exhaust type
C	For Manifold	Complex exhaust*1 
		Individual port exhaust 
H	High-noise reduction silencer exhaust 	High-noise reduction silencer exhaust 

*1 Combination of direct exhaust and end plate exhaust from each station

2 Nominal nozzle size

Symbol	Nominal nozzle size
07	Ø 0.7
10	Ø 1.0
12	Ø 1.2
15	Ø 1.5

* Refer to page 18 for the standard supply pressure per nozzle diameter.

3 Combination of supply valve and release valve

Symbol	Supply valve	Release valve
	N.C.	N.C.
K	●	●

4 Rated voltage (Supply valve/Release valve)

Symbol	Voltage
5	24 VDC
6	12 VDC

5 Pressure switch for vacuum with energy saving function

Symbol	Pressure range [kPa]	Specifications		
		NPN	PNP	With unit selection function*2
K	-100 to 100	●	—	●
Q		●	—	None (SI unit only)
R		—	●	●
S		—	●	None (SI unit only)

*2 The unit for the type without the unit selection function is fixed as kPa.

6 Connector

Symbol	For pressure switch for vacuum with energy saving function: 2 m (Lead wire with connector)
W	●
L3	None

7 Vacuum (V) port

Symbol	Vacuum (V) port
06	Ø 6
08	Ø 8
07	Ø 1/4"
09	Ø 5/16"

8 Option*3 (For details on the Function/Application, refer to page 42.)

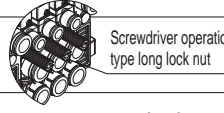
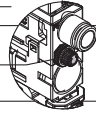
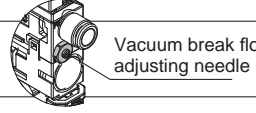
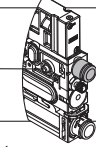
Symbol	Type	Note
—	Without option	—
E	Screwdriver operation type long lock nut 	Can be selected only for the combination of J and K
J	Round lock nut 	
K	Screwdriver operation type 	
L	Manifold individual supply specification*4 	—
P	With manifold common release pressure supply (PD) port	Cannot be selected when 3 is J

*3 When more than one option is selected, list the option symbols in alphabetical order. (Example -EL)

*4 When F or H is selected for 1 and L is selected for the option, the space for adjusting the needle is reduced. Products which can be operated more easily can be specified by option E or K.

Ejector System Vacuum Unit

ZK2□A Series



Single Unit For Manifold Ejector + Without Valve + Without Energy Saving Function

Refer to page 14 for How to Order Manifold.

How to Order

ZK2 **A** **10** **N** **0** **N** **N** **A** - **08** - □

1
2
3
4
5
6

1 Body/Exhaust type

Symbol	Body	Exhaust type
A	Single unit	Silencer exhaust*1
		Port exhaust
G	Single unit	High-noise reduction silencer exhaust
C	For Manifold	Complex exhaust*2
		Individual port exhaust
H	For Manifold	High-noise reduction silencer exhaust

*1 With exhaust port when 2 is 12 or 15

*2 Combination of direct exhaust and end plate exhaust from each station

2 Nominal nozzle size

Symbol	Nominal nozzle size
07	∅ 0.7
10	∅ 1.0
12	∅ 1.2
15	∅ 1.5

* Refer to page 18 for the standard supply pressure per nozzle diameter.

4 Connector

Symbol	For pressure switch for vacuum: 2 m (Lead wire with connector)	Pressure sensor assembly: 3 m (With lead wire)	Note
Y	●		Cannot be selected when 3 is N
Y1	None		Cannot be selected when 3 is P, T, or N
N	None		When "N" is selected for 3

3 Pressure switch for vacuum/Pressure sensor

Symbol	Type	Pressure range [kPa]	Specifications		
			NPN 2 outputs	PNP	With unit selection function*3
A	Pressure switch for vacuum	-101 to 0	●	—	●
B			●	—	None (SI unit only)
C			—	●	●
D		-100 to 100	—	●	None (SI unit only)
E			●	—	●
F			●	—	None (SI unit only)
H	—	●	●		
J	—	●	●	None (SI unit only)	
P	Pressure sensor	-101 to 0	Analogue output 1 to 5 V		
T	Pressure sensor	-100 to 100			
N	Without pressure switch for vacuum/pressure sensor				

*3 The unit for the type without the unit selection function is fixed as kPa.

5 Vacuum (V) port

Symbol	Vacuum (V) port
06	∅ 6
08	∅ 8
07	∅ 1/4"
09	∅ 5/16"

6 Option*4 (For details on the Function/Application, refer to page 42.)

Symbol	Type	Note
—	Without option	—
B	Mounting bracket for single unit (nuts and bolts are included)	Cannot be selected when 1 is C, F, or H
L	Manifold individual supply specification*5	Cannot be selected when 1 is A, B, or G
W	With exhaust interference prevention valve	Install the release valve or vacuum breaker in the middle of the vacuum piping.

*4 When more than one option is selected, list the option symbols in alphabetical order. (Example -BW)

*5 When F or H is selected for 1 and L is selected for the option, the space for adjusting the needle is reduced. Products which can be operated more easily can be specified by option E or K.

Ejector System Vacuum Unit

ZK2□A Series



Manifold

Refer to pages 11 to 13 for the ejector installed to the manifold.

How to Order Manifold

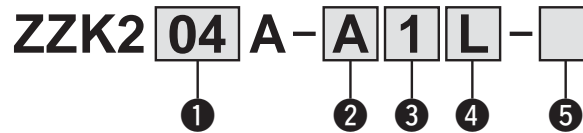

① Stations

Symbol	Stations
01	1 station
02	2 stations
⋮	⋮
10	10 stations

* For adequate performance, the number of stations that can be operated simultaneously depends on the nozzle diameter. Refer to the Max. Number of Manifold Stations that can be Operated Simultaneously in page 18.

② System/Port

Symbol	System	Port
A	Ejector system	∅ 8 (Common PV)
AN		∅ 5/16" (Common PV)

③ Exhaust

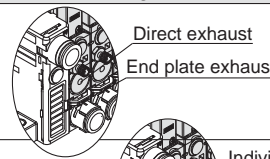
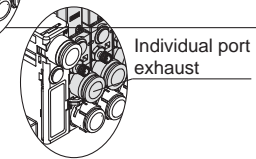
Symbol	Exhaust	Selectable single unit number
1	Complex exhaust*1	ZK2C 
2	Individual exhaust	ZK2F, ZK2H 

*1 Combination of direct exhaust and end plate exhaust from each station

④ Supply valve and release valve wiring*2

Symbol	Wiring	Selectable wiring for manifold (Refer to ⑥ on pages 11 and 12, and ④ on page 13.)									
		C	C1	L	L1	L2	L3	W	Y	Y1	N
L	Individual wiring	—	—	●	●	●	●	●	—	—	—
F	D-sub connector	●	●	—	—	—	—	—	—	—	—
P	Flat ribbon cable connector	●	●	—	—	—	—	—	—	—	—
N	No wiring (No valve)	—	—	—	—	—	—	—	●	●	●

*2 Common wiring F/P is available only for solenoid valve wiring. Individual wiring is specified for vacuum switches and sensors.

⑤ Option*3 (For details on the Function/Application, refer to page 42.)

Symbol	Type	Selectable option for manifold (Refer to ⑧ on pages 11 and 12, and ⑥ on page 13.)					
		E	J	K	L	P	W
—	Without option	●	●	●	—	—	●
B	With DIN rail mounting bracket*4	●	●	●	—	—	●
D	With common release pressure supply (PD) port	●	●	●	—	⊙*5	●
L	Manifold individual supply specification Individual supply port	●	●	●	⊙*5	—	●

*3 When more than one option is selected, list the option symbols in alphabetical order. (Example -BD)

*4 The DIN rail should be ordered separately. (Refer to page 33.)

*5 When the option D is selected, select P for single unit for manifold. When the option L is selected, select L for single unit for manifold. (⊙ must be selected.)

How to Order Valve Manifold Assembly

Example

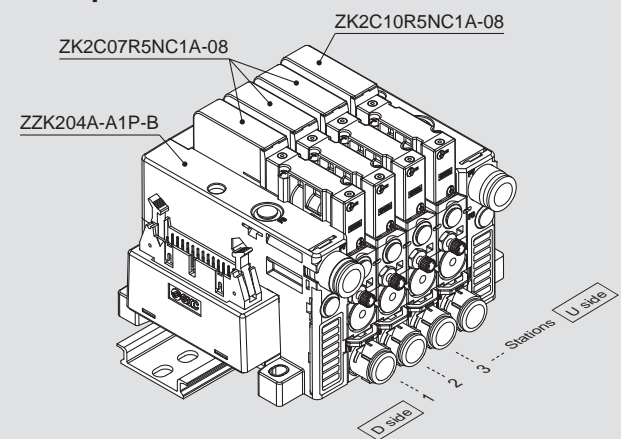

ZZK204A-A1P-B 1 set (Manifold part number)
 * ZK2C07R5NC1A-08 3 sets
 * ZK2C10R5NC1A-08 1 set
 * The asterisk denotes the symbol for the assembly.
 * Prefix to the single unit part number.

- When the manifold is viewed from V port, the first station starts from the left (D side).
- After the manifold part number, specify the installed single unit from the first station.
- Complex exhaust and individual port exhaust cannot be mixed in the ejector system manifold.
- The DIN rail should be ordered separately. (Refer to page 33.)

How to Order

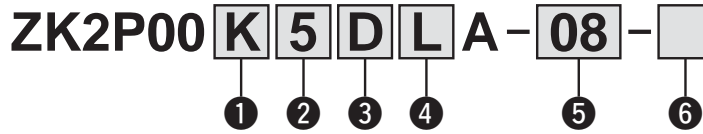

① Combination of supply valve and release valve

Symbol	Supply valve		Release valve
	N.C.	Self-holding	N.C.
K	●	—	●
J	●*1	—	—
R	—	●*2	●

- *1 Install the release valve or vacuum breaker in the middle of the vacuum piping.
- *2 Supply valve maintains vacuum by energisation (20 ms or more). Stopping the vacuum turns on the release valve.
Refer to the precaution on page 44.

② Rated voltage (Supply valve/Release valve)

Symbol	Voltage
5	24 VDC
6	12 VDC

③ Pressure switch for vacuum/Pressure sensor

Symbol	Type	Pressure range [kPa]	Specifications		
			NPN	PNP	With unit selection function*3
A	Pressure switch for vacuum	-101 to 0	●	—	●
B			●	—	None (SI unit only)
C			—	●	●
D			—	●	None (SI unit only)
E			●	—	●
F	Pressure sensor	-100 to 100	●	—	None (SI unit only)
H			—	●	●
J			—	●	None (SI unit only)
P	Pressure sensor	-101 to 0	Analogue output 1 to 5 V		
T		-100 to 100			
N	Without pressure switch for vacuum/pressure sensor				

- *3 The unit selection function is not available in Japan due to the New Measurement Law. The unit for the type without the unit selection function is fixed as kPa.

④ Connector (Supply valve/Release valve/Pressure switch for vacuum)

Symbol	For supply valve/release valve: 300 mm (Connector assembly)*4	For pressure switch for vacuum: 2 m (Lead wire with connector)	Pressure sensor assembly: 3 m (With lead wire)	Note
L	●	—	●	Cannot be selected when ③ is N
L1	None	—	●	
L2	●	—	None	Cannot be selected when ③ is P or T
L3	None	—	None	

- *4 For the connector length other than 300 mm, order the connector assembly on page 32 separately.

⑤ Vacuum (V) port

Symbol	Vacuum (V) port
06	∅ 6
08	∅ 8
07	∅ 1/4"
09	∅ 5/16"

⑥ Option*5 (For details on the Function/Application, refer to page 42.)

Symbol	Type	Note	
—	Without option	—	
B	Mounting bracket for single unit (nuts and bolts are included)	—	
C	Vacuum pump system PE port female thread specification (M3)	PE port	
D	With individual release pressure supply (PD) port (M3)*6	PD port	
E	Vacuum break flow adjusting needle	Cannot be selected when ① is J Can be selected only for the combination of J and K	
J			Screwdriver operation type long lock nut Lock nut
K			Round lock nut Screwdriver operation type Vacuum break flow adjusting needle

- *5 When more than one option is selected, list the option symbols in alphabetical order. (Example -BJ)
- *6 Use a One-touch fitting or barb fitting (M-3AU-4) for piping. (O.D.: Within ∅ 6.2)

Refer to page 17 for How to Order Manifold.

How to Order

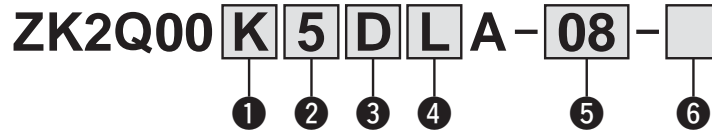

① Combination of supply valve and release valve

Symbol	Supply valve		Release valve
	N.C.	Self-holding	N.C.
K	●	—	●
J	●*1	—	—
R	—	●*2	●

- *1 Install the release valve or vacuum breaker in the middle of the vacuum piping.
- *2 Supply valve maintains vacuum by energisation (20 ms or more). Stopping the vacuum turns on the release valve. Refer to the precaution on page 44.

② Rated voltage (Supply valve/Release valve)

Symbol	Voltage
5	24 VDC
6	12 VDC

③ Pressure switch for vacuum/Pressure sensor

Symbol	Type	Pressure range [kPa]	Specifications		
			NPN	PNP	With unit selection function*3
A	Pressure switch for vacuum	-101 to 0	●	—	●
B			●	—	None (SI unit only)
C			—	●	●
D			—	●	None (SI unit only)
E			●	—	●
F			●	—	None (SI unit only)
H	Pressure sensor	-100 to 100	—	●	●
J			—	●	None (SI unit only)
P			—	●	None (SI unit only)
T	Pressure sensor	-101 to 0	Analogue output 1 to 5 V		
		-100 to 100			
N	Without pressure switch for vacuum/pressure sensor				

*3 The unit for the type without the unit selection function is fixed as kPa.

④ Connector (Supply valve/Release valve/Pressure switch for vacuum)

Symbol	For supply valve/release valve		For pressure switch for vacuum: 2 m (Lead wire with connector)	Pressure sensor assembly: 3 m (With lead wire)	Note
	Centralised wiring specification (Plug-in)	Individual wiring specification: 300 mm (Connector assembly)*4			
C	●	None	●	●	Cannot be selected when ③ is N
C1	●	None	None	None	Cannot be selected when ③ is P or T
L	None	●	●	●	Cannot be selected when ③ is N
L1	None	None	None	None	
L2	None	●	None	None	
L3	None	None	None	None	Cannot be selected when ③ is P or T

*4 For the connector length other than 300 mm, order the connector assembly on page 32 separately.

⑤ Vacuum (V) port

Symbol	Vacuum (V) port
06	∅ 6
08	∅ 8
07	∅ 1/4"
09	∅ 5/16"

⑥ Option*5 (For details on the Function/Application, refer to page 42.)

Symbol	Type	Note	
—	Without option	—	
C	Vacuum pump system PE port female thread specification (M3)	PE port When R is selected for ①, P needs to be selected.	
E	Vacuum break flow adjusting needle	Screwdriver operation type long lock nut Screwdriver operation type long lock nut Round lock nut Lock nut Screwdriver operation type Vacuum break flow adjusting needle	
J			Cannot be selected when ① is J Can be selected only for the combination of J and K
K			
P	With manifold common release pressure supply (PD) port	Cannot be selected when ① is J	

*5 When more than one option is selected, list the option symbols in alphabetical order. (Example -EP)

Vacuum Pump System Vacuum Unit

ZK2□A Series



Manifold

Refer to page 16 for the vacuum pump system for the manifold.

How to Order Manifold

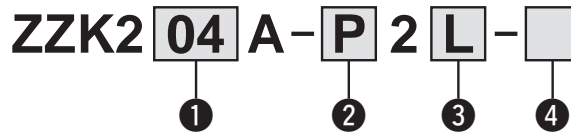

1 Stations

Symbol	Stations
01	1 station
02	2 stations
⋮	⋮
10	10 stations

2 System/Port

Symbol	System	Port
P	Vacuum pump system	∅ 8 (Common PV) ∅ 6 (Common PS)
PN		∅ 5/16" (Common PV) ∅ 1/4" (Common PS)

3 Supply valve and release valve wiring*1

Symbol	Wiring	Selectable wiring for manifold 4 (Refer to page 16.)					
		C	C1	L	L1	L2	L3
L	Individual wiring	—	—	●	●	●	●
F	D-sub connector	●	●	—	—	—	—
P	Flat ribbon cable connector	●	●	—	—	—	—

*1 Common wiring F/P is available only for solenoid valve wiring. Individual wiring is specified for vacuum switches and sensors.

4 Option*2 (For details on the Function/Application, refer to page 42.)

Symbol	Type	Selectable option for manifold 6 (Refer to page 16.)				
		C	E	J	K	P
—	Without option	●	●	●	●	—
B	With DIN rail mounting bracket*3	●	●	●	●	—
D	With common release pressure supply (PD) port	●	●	●	●	◎*4

- *2 When more than one option is selected, list the option symbols in alphabetical order. (Example -BD)
- *3 The DIN rail should be ordered separately. (Refer to page 33.)
- *4 When D is selected for manifold option, select P for single unit option. (◎ must be selected.)

How to Order Valve Manifold Assembly

Example

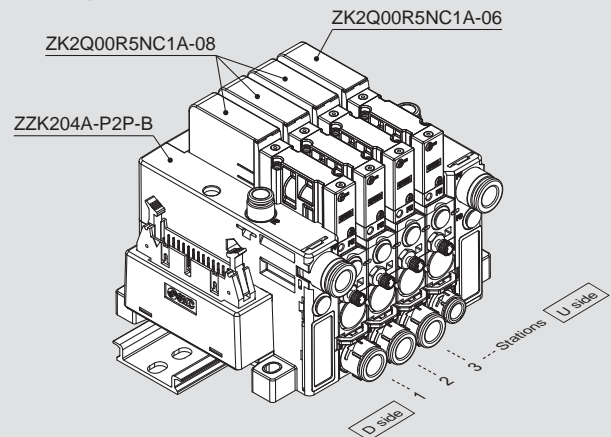

ZZK204A-P2P-B 1 set (Manifold part number)
 * ZK2Q00R5NC1A-08 3 sets
 * ZK2Q00R5NC1A-06 1 set

↳ * The asterisk denotes the symbol for the assembly.
 * Prefix to the single unit part number.

- When the manifold is viewed from V port, the first station starts from the left (D side).
- After the manifold part number, specify the installed single unit from the first station.
- The DIN rail should be ordered separately. (Refer to page 33.)

Specifications

General Specifications

Operating temperature range (No condensation)	-5 to 50 °C	Without pressure sensor/switch	With pressure sensor
	0 to 50 °C	With pressure sensor	
	5 to 50 °C	Pressure switch with energy saving function	
Fluid	Air		
Vibration resistance*1	30 m/s ²	Without pressure sensor/switch	With pressure sensor
	20 m/s ²	With pressure switch	
Impact*2, *3 resistance	150 m/s ²	Without pressure sensor/switch	With pressure sensor
	100 m/s ²	With pressure switch	
Standards	CE marking, RoHS		

- *1 The characteristics are satisfied when tested for 2 hours in each of the X, Y and Z directions at 10 to 500 Hz without energisation. (Initial value)
 *2 The characteristics are satisfied when tested one time in each of the X, Y and Z directions without energisation. (Initial value)
 *3 For valve type R (Self-holding release valve linked), impact resistance is 50 m/s².

Valve Common Specifications

Model*4	ZK2-VA□K	ZK2-VA□R	ZK2-VA□J
Type of actuation*5	Supply valve: N.C. Release valve: N.C.	Self-holding release valve linked Release valve: N.C.	Supply valve: N.C. Release valve: None
Valve configuration*6	Pilot operated dual 2-port		Pilot operated 2-port
Operating pressure range	0.3 to 0.6 MPa		
Valve construction	Poppet seal		
Manual override	Push type		
Rated voltage	24 VDC, 12 VDC		
Power consumption	0.4 W		
Lead wire (ZK2-LV**A)	Cross section: 0.2 mm ² (AWG24)		
	Insulator O.D.: 1.4 mm		

- *4 Refer to the Valve assembly on page 32 for the valve model number.
 *5 ZK2-VA□R: After instantaneous energisation of the supply valve (20 ms or more), ON state is maintained without energisation. Supply valve turns off simultaneously when the release valve turns on.
 ZK2-VA□K: Supply valve turns off when is not energised. Select this type when energy saving switch is used.
 *6 The V100 series is used as the pilot valve. For details on the V100 series, refer to the V100 series in the **Web Catalogue** and the 3/4/5-port solenoid valve precautions.

Ejector Specifications

Item	Model	ZK2□07	ZK2□10	ZK2□12	ZK2□15	
Nozzle diameter	[mm]	0.7	1.0	1.2	1.5	
Max. suction flow*7	Port exhaust	[l/min (ANR)]	34	56	74	89
	Silencer exhaust/ Complex exhaust	[l/min (ANR)]	29	44	61	67
	High-noise reduction silencer exhaust	[l/min (ANR)]	34	56	72	83
Air consumption*7	[l/min (ANR)]	24	40	58	90	
Max. vacuum pressure*7	[kPa]	-91				
Supply pressure range*8	[MPa]	0.3 to 0.6 (0.1 to 0.6)				
Standard supply pressure*9	[MPa]	0.35		0.4 (0.37)		

- *7 Values at the standard supply pressure. Values are based on standard of SMC measurements. They depend on atmospheric pressure (weather, altitude, etc.) and measurement method.
 *8 The value in () is for without valve.
 *9 The value in () is for without valve. For nozzle size 07 to 12, the value is common to the ejectors with valve and without valve.

Suction Filter

Nominal filtration rating	30 μm
Filtration area	510 mm ²

Max. Number of Manifold Stations that Can Operate Simultaneously*10

Item	Model (Nozzle size)	ZK2□07	ZK2□10	ZK2□12	ZK2□15	
Air pressure supply (PV) port ∅ 8, ∅ 5/16"	Complex exhaust	Supply from one side	8	5	4	3
		Supply from both sides	10	7	5	5
	Individual port exhaust, High-noise reduction silencer exhaust	Supply from one side	8	6	6	3
		Supply from both sides	10	9	9	6

- *10 As long as the number of stations operated simultaneously is the value on the table or less, then the manifold is available up to 10 stations.

Noise Level (Reference values)

Item	Model	ZK2□07	ZK2□10	ZK2□12	ZK2□15
Noise level [dB (A)]	ZK2G (High-noise reduction silencer exhaust)	46	55	63	69
	ZK2A (Silencer exhaust)	59	66	75	76

Actual values under SMC's measurement conditions (Not guaranteed values)

Weight

Single Unit

Single unit model	Weight [g]
ZK2P00K□N□A (Vacuum pump system, Single unit, Without pressure sensor/switch)	97
ZK2A□K□N□A (Ejector system, Single unit, Without pressure sensor/switch)	95
ZK2A□N0NN (Ejector system, Single unit, Without valve)	54
ZK2 (One station for manifold, Without pressure sensor/switch)	99

Pressure Sensor/Pressure Switch for Vacuum

Pressure sensor/Pressure switch for vacuum model	Weight [g]
ZK2-PS□-A (Except cable portion)	5
ZK2-ZS□-A (Except lead wire with connector)	14

Manifold Base

	1 station	2 stations	3 stations	4 stations	5 stations	6 stations	7 stations	8 stations	9 stations	10 stations
Weight [g]	129	132	135	138	141	144	147	149	152	155

● Calculation of Weight for the Manifold Type

(Single unit weight x Number of stations) + (Pressure sensor/Pressure switch for vacuum weight x Number of stations) + Manifold base

Example) 5-station manifold with pressure sensors

$$99 \text{ g} \times 5 \text{ pcs.} + 5 \text{ g} \times 5 \text{ pcs.} + 141 \text{ g} = \mathbf{661 \text{ g}}$$

ZK2□A Series

Ejector Exhaust Characteristics/Flow Rate Characteristics (Representative value)

* The flow rate characteristics correspond to the standard supply pressure.

ZK2□07

Exhaust Characteristics

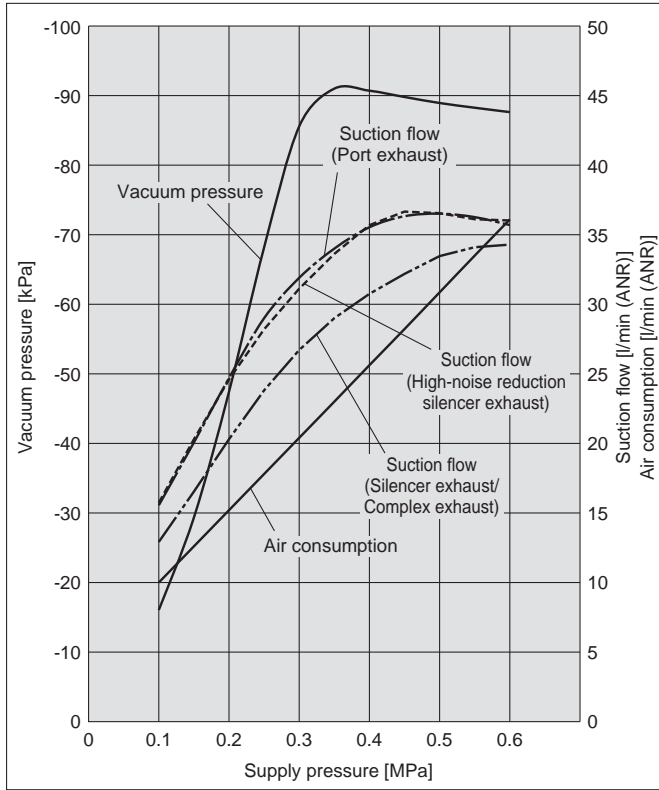

Flow Rate Characteristics

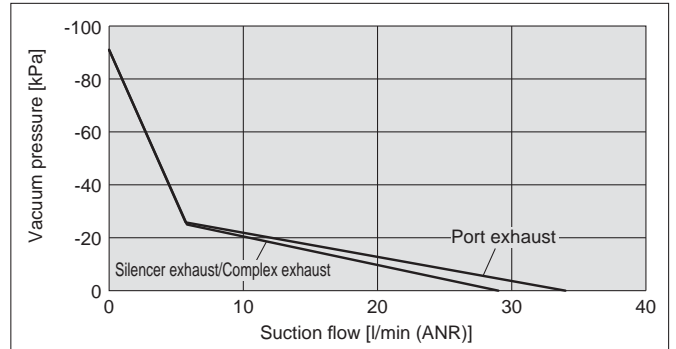

Flow Rate Characteristics

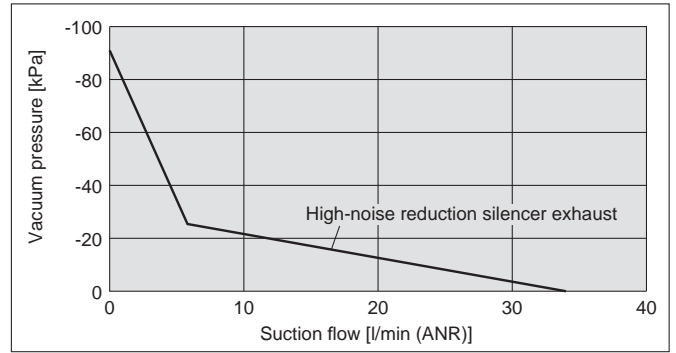

ZK2□10

Exhaust Characteristics

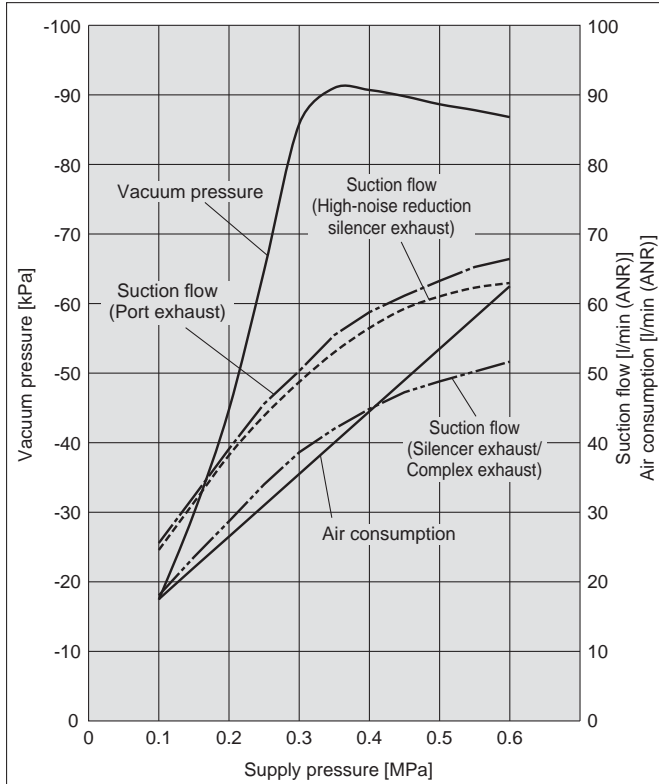

Flow Rate Characteristics

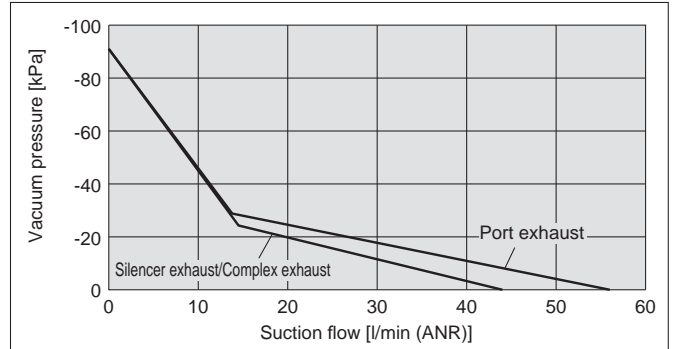

Flow Rate Characteristics

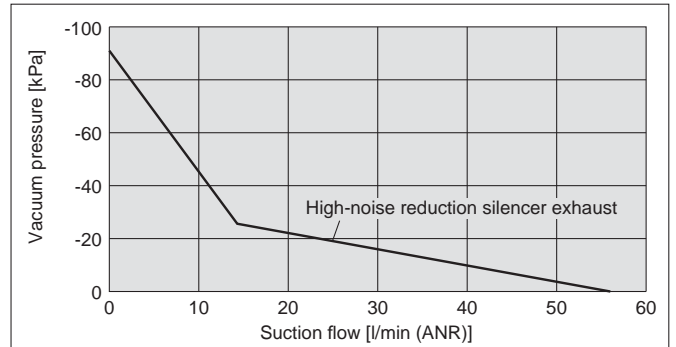

Ejector Exhaust Characteristics/Flow Rate Characteristics (Representative value)

* The flow rate characteristics correspond to the standard supply pressure.

ZK2□12

Exhaust Characteristics

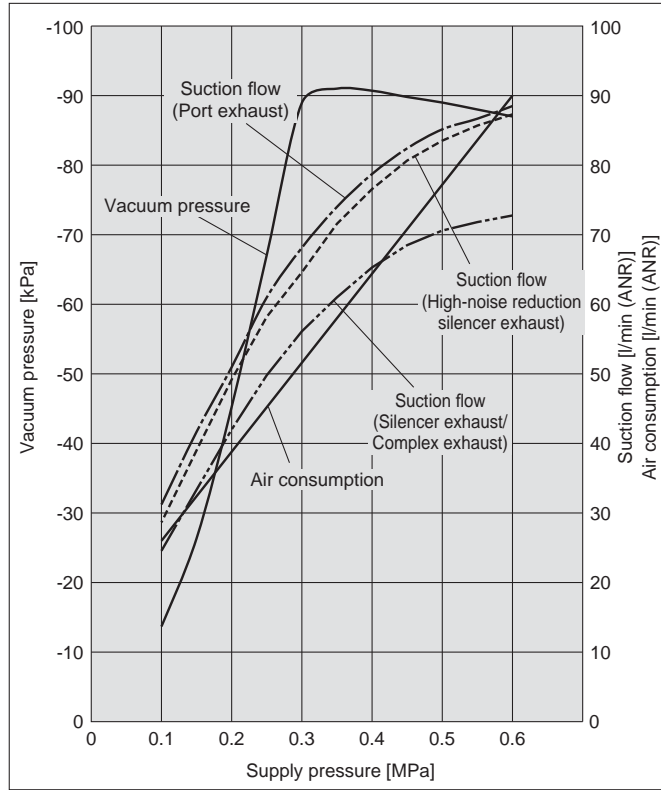

Flow Rate Characteristics

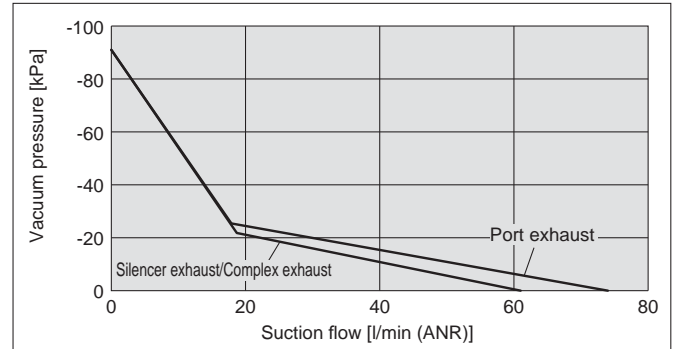

Flow Rate Characteristics

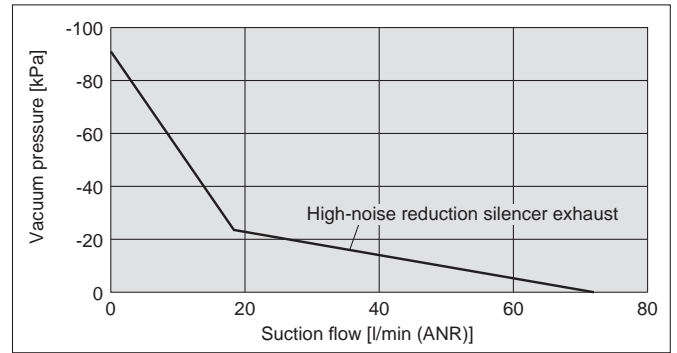

ZK2□15 * The following graphs show the characteristics of the ejector with valve. (Please contact SMC for models without valve.)

Exhaust Characteristics

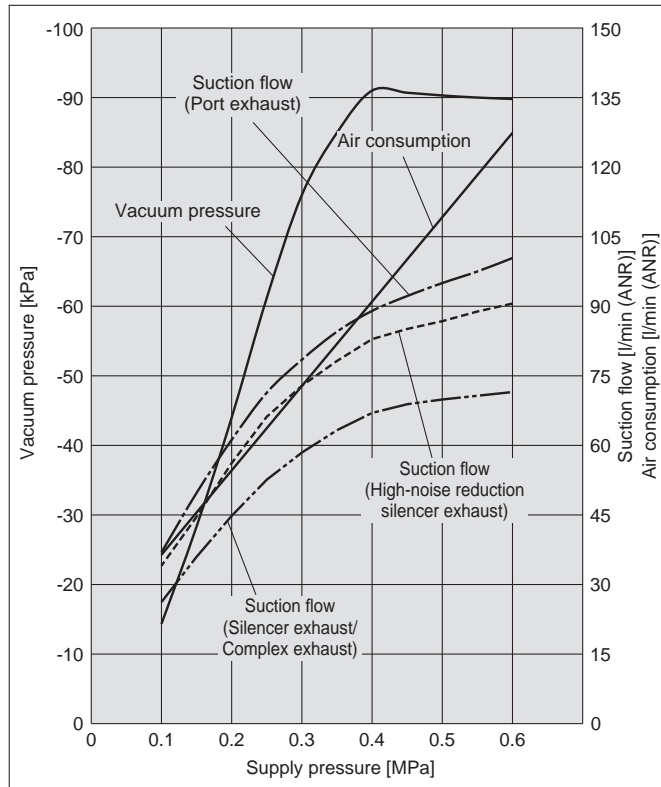

Flow Rate Characteristics

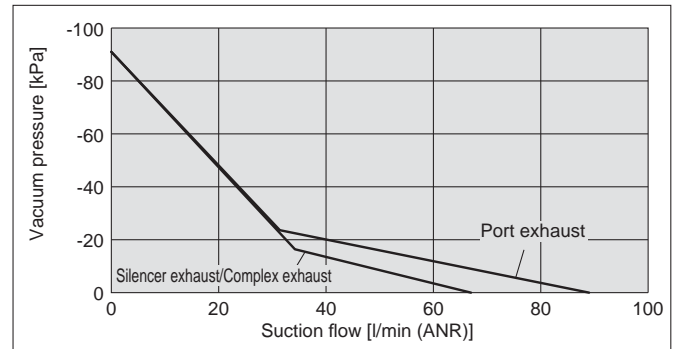

Flow Rate Characteristics

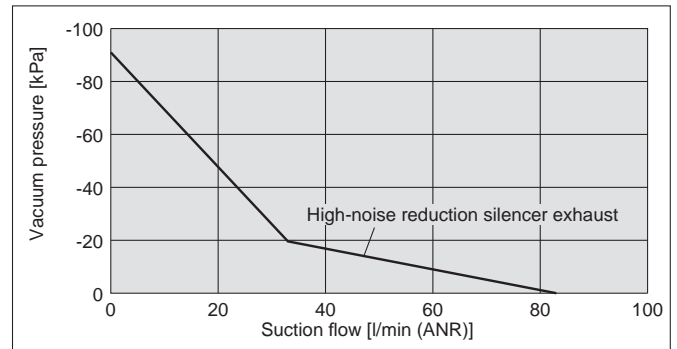

ZK2□□A Series

Vacuum Pump System Flow Rate Characteristics/ZK2P00

The graph shows the suction flow rate characteristics of the vacuum pump system at different vacuum pressures.

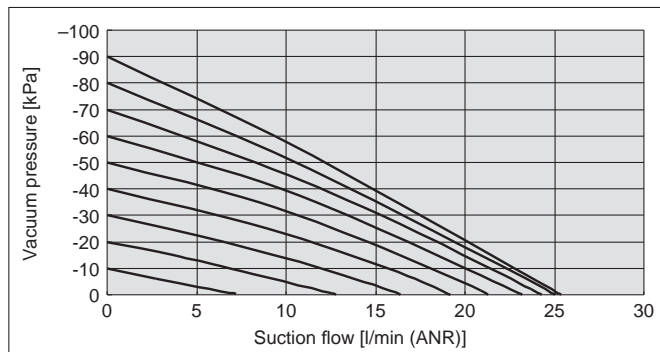

The actual suction flow at the point of suction varies depending on the piping conditions to the vacuum port. (The above graph shows the value when V port is $\varnothing 8$.)

Vacuum Release Flow Rate Characteristics

The graph shows the flow rate characteristics at different supply pressures when the vacuum break flow adjusting needle is open from the fully closed state.

ZK2□□□(Ejector system)

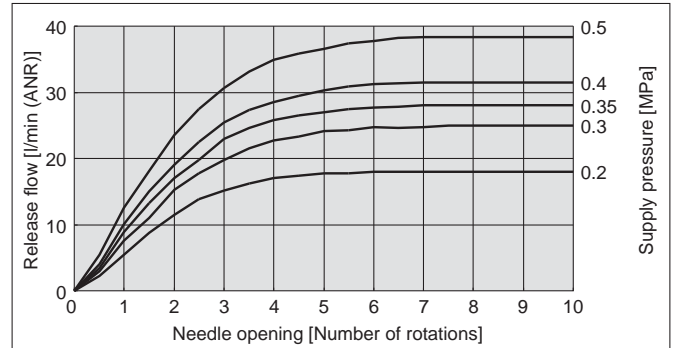

The actual suction flow at the point of suction varies depending on the piping conditions to the vacuum port. (The above graph shows the value of the ZK2B07.)

ZK2□□□(Pump system)

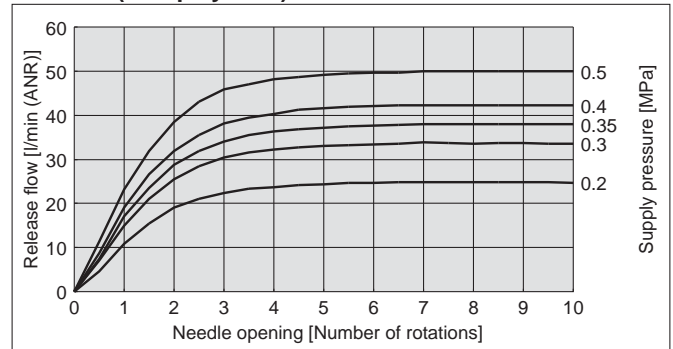

The actual suction flow at the point of suction varies depending on the piping conditions to the vacuum port.

Vacuum Pump System Flow Rate Characteristics of Flow Path and Vacuum Release

Port size		Flow rate characteristics of V → PV (Vacuum side)				Flow rate characteristics of PS → V (Vacuum release side)*1			
PV port	V port	C[dm ³ /(s·bar)]	b	Cv	Q [l/min (ANR)]*2	C[dm ³ /(s·bar)]	b	Cv	Q [l/min (ANR)]*2
$\varnothing 6$	$\varnothing 8$	0.39	0.14	0.09	90	0.20	0.06	0.04	45

*1 When needle is fully open

*2 These values have been calculated according to ISO 6358 and indicate the flow rate under standard conditions with an inlet pressure of 0.6 MPa (relative pressure) and a pressure drop of 0.1 MPa.

How to Read the Flow Rate Characteristics Graph

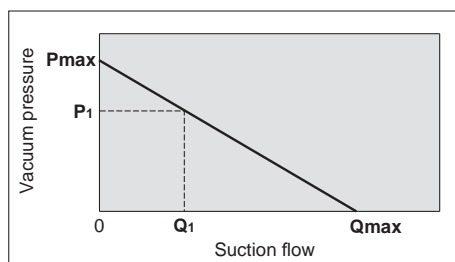

The flow rate characteristics indicate the relationship between the vacuum pressure and the suction flow of the ejector. They also show that when the suction flow changes, the vacuum pressure also changes. In general, this indicates the relationship at the ejector's standard operating pressure. In the graph, **Pmax** indicates the max. vacuum pressure, and **Qmax** indicates the max. suction flow. These are the values that are published as specifications in catalogues, etc. Changes in vacuum pressure are explained in the order below.

1. If the ejector's suction port is closed and sealed tight, the suction flow becomes "0," and the vacuum pressure increases to the max. (**Pmax**).
2. If the suction port is opened gradually and air is allowed to flow (the air leaks), the suction flow increases, and the vacuum pressure decreases. (The condition of **P1** and **Q1**)
3. If the suction port is opened completely, the suction flow increases to the max. (**Qmax**), while the vacuum pressure then drops almost to "0" (atmospheric pressure).

As described above, the vacuum pressure changes when the suction flow changes. In other words, when there is no leakage from the vacuum (V) port, the vacuum pressure can reach its maximum, but as the amount of leakage increases, the vacuum pressure decreases. When the amount of leakage and the maximum suction flow become equal, the vacuum pressure becomes almost zero. When adsorbing workpieces which are permeable, subject to leakage, etc., caution is required as the vacuum pressure will not be very high.

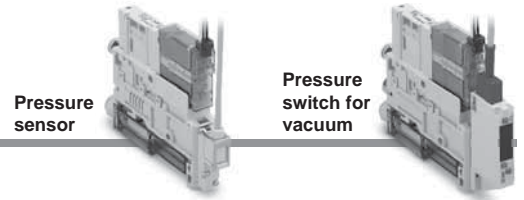

Pressure Sensor/Pressure Switch for Vacuum Specifications

Pressure Sensor (For details, refer to the PSE series in the **Web Catalogue**, and the Operation Manual.)

Model (Sensor unit: Standard model number)		ZK2-PS1-A (PSE541)	ZK2-PS3-A (PSE543)
Rated pressure range		-101 to 0 kPa	-100 to 100 kPa
Proof pressure		500 kPa	
Output voltage		1 to 5 VDC	
Output impedance		Approx. 1 kΩ	
Power supply voltage		10 to 24 VDC ±10 %, Ripple (p-p) 10 % or less	
Current consumption		15 mA or less	
Accuracy		±2 % F.S. (Ambient temperature at 25 °C)	
Linearity		±0.4 % F.S.	
Repeatability		±0.2 % F.S.	
Effect of power supply voltage		±0.8 % F.S.	
Environmental resistance	Temperature range	Stored: -20 to 70 °C (No condensation or freezing)	
	Humidity range	Operating/Stored: 35 to 85 % RH (No condensation)	
Temperature characteristics		±2 % F.S. or less (Ambient temperature: 25 °C reference)	
Material	Case	Resin case: PBT	
	Pressure sensing section	Sensor pressure receiving area: Silicon, O-ring: HNBR	
Lead wire		Oil-resistant vinyl cable (elliptic) 3 cores, 2.7 x 3.2 mm, 3 m Cross section: 0.15 mm ² Insulator O.D.: 0.9 mm	

Pressure Switch for Vacuum (For details, refer to the ZSE/ISE10 series in the **Web Catalogue**, and the Operation Manual.)

Model (Switch unit: Standard model number)		ZK2-ZSE <input type="checkbox"/> <input type="checkbox"/> <input type="checkbox"/> -A (ZSE10)	ZK2-ZSF <input type="checkbox"/> <input type="checkbox"/> <input type="checkbox"/> -A (ZSE10F)
Rated pressure range		-101 to 0 kPa	-100 to 100 kPa
Set pressure range/Pressure display range		-105 to 10 kPa	-105 to 105 kPa
Proof pressure		500 kPa	
Smallest settable increment		0.1 kPa	
Power supply voltage		12 to 24 VDC ±10 %, Ripple (p-p) 10 % or less (Protected against reverse connection)	
Current consumption		40 mA or less	
Switch output	Output type	NPN or PNP open collector 2 outputs (selectable)	
	Max. load current	80 mA	
	Max. applied voltage	28 V (with NPN output)	
	Residual voltage	2 V or less (at load current of 80 mA)	
	Response time	2.5 ms or less (with anti-chattering function: 20, 100, 500, 1000, 2000 ms)	
	Short circuit protection	Yes	
Repeatability		±0.2 % F.S. ±1 digit	
Hysteresis	Hysteresis mode	Variable from 0*1	
	Window comparator mode		
Display type		3 1/2 digit, 7-segment LED, 1-colour display (Red)	
Display accuracy		±2 % F.S. ±1 digit (Ambient temperature at 25 ±3 °C)	
Indicator light		Lights up when output is turned ON. OUT1: Green, OUT2: Red	
Environmental resistance	Enclosure	IP40	
	Temperature range	Stored: -10 to 60 °C (No condensation or freezing)	
	Humidity range	Operating/Stored: 35 to 85 % RH (No condensation)	
	Withstand voltage	1000 VAC for 1 minute between terminals and housing	
Insulation resistance		50 MΩ or more (500 VDC measured via megohmmeter) between terminals and housing	
Temperature characteristics		±2 % F.S. (Ambient temperature: based on 25 °C)	
Lead wire		Oilproof heavy-duty vinyl cable 5 cores Ø 3.5, 2 m Cross section: 0.15 mm ² (AWG26) Insulator O.D.: 1.0 mm	

*1 If the applied pressure fluctuates around the set value, the hysteresis must be set to a value more than the fluctuating width. Otherwise, chattering will occur.

Description (Pressure Switch for Vacuum)

Output (OUT1) display (Green)	Lights up when OUT1 is turned ON.
Output (OUT2) display (Red)	Lights up when OUT2 is turned ON. Pressure switch for vacuum with energy saving function: LED (Red) is ON when the pilot valve for supply valve is energised.
LED display	Displays the current pressure, set mode and error code.
▲ button (UP)	Selects the mode or increases the ON/OFF set value. Use for switching to the peak display mode.
▼ button (DOWN)	Selects the mode or decreases the ON/OFF set value. Use for switching to the bottom display mode.
Ⓢ button (SET)	Use for changing the mode or setting the set value.

* Refer to the Operation Manual for details on each setting and operation methods.

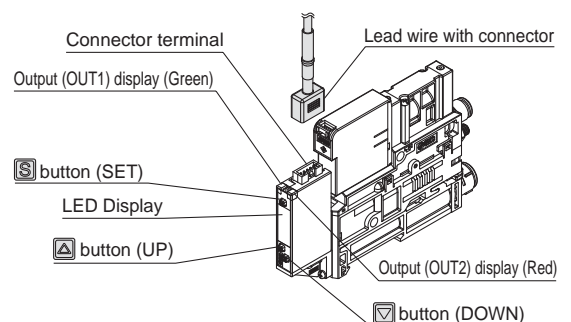

ZK2□A Series

Pressure Switch for Vacuum with Energy Saving Function Specifications

Pressure switch for vacuum with energy saving function

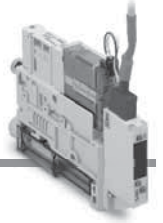

Pressure Switch for Vacuum with Energy Saving Function

(For details, refer to the Operation Manual for the ZK2-ZSV□□□-A on the SMC website.)

Model		ZK2-ZSV□□□-A
Rated pressure range		-100 to 100 kPa
Set pressure range		-105 to 105 kPa
Proof pressure		500 kPa
Smallest settable increment		0.1 kPa
Power supply voltage		12 to 24 VDC $\pm 10\%$, Ripple (p-p) 10% or less (Protected against reverse connection)
Current consumption		40 mA or less
Switch output	Output type	NPN or PNP open collector OUT1: General purpose, OUT2: Valve control
	Max. load current	80 mA
	Max. applied voltage	26.4 VDC
	Residual voltage	2 V or less (at load current of 80 mA)
	Response time	2.5 ms or less (with anti-chattering function: 20, 100, 500, 1000, 2000 ms)
Short circuit protection		Yes
Repeatability		$\pm 0.2\%$ F.S. ± 1 digit
Hysteresis	Hysteresis mode	Variable from 0*1
Display type		3 1/2 digit, 7-segment LED, Colour display (Red)
Display accuracy		$\pm 2\%$ F.S. ± 1 digit (Ambient temperature at 25 ± 3 °C)
Indicator light		Lights up when output is turned ON. OUT1: Green, OUT2: Red
Environmental resistance	Enclosure	IP40
	Operating temperature range	5 to 50 °C
	Withstand voltage	1000 VAC for 1 minute between terminals and housing
Insulation resistance		50 M Ω or more (500 VDC measured via megohmmeter) between terminals and housing
Temperature characteristics		$\pm 2\%$ F.S. (at 25 °C in an operating temperature range of 5 and 50 °C)
Lead wire		Cable: 5 cores $\varnothing 3.5$, 2 m Cross section: 0.15 mm ² (AWG26) Insulator O.D.: 1.0 mm

*1 If the applied pressure fluctuates around the set value, the hysteresis must be set to a value more than the fluctuating width. Otherwise, chattering will occur.

Internal Circuit and Wiring Example

Pressure Sensor

ZK2-PS□-A

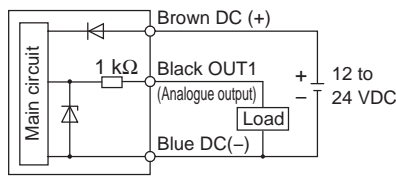

Voltage output type: 1 to 5 V
Output impedance: Approx. 1 k Ω

Pressure Switch for Vacuum

ZK2-ZS□A□□-A (NPN 2 outputs)

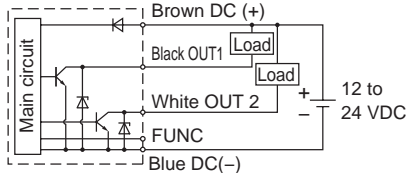

Max. 28 V, 80 mA
Residual voltage: 2 V or less

ZK2-ZS□B□□-A (PNP 2 outputs)

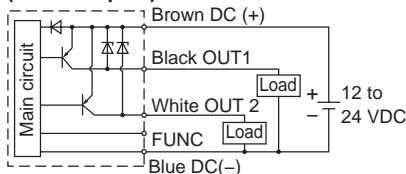

Max. 80 mA
Residual voltage: 2 V or less

* The FUNC terminal is connected when using the copy function.
(For details, refer to the Operation Manual for the ZSE10/ISE10 on the SMC website.)

Pressure Switch for Vacuum with Energy Saving Function

ZK2-ZSVA□□-A (NPN 1 output)

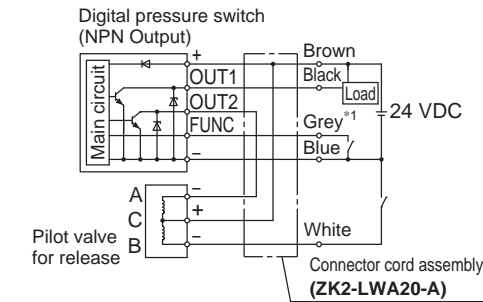

ZK2-ZSVB□□-A (PNP 1 output)

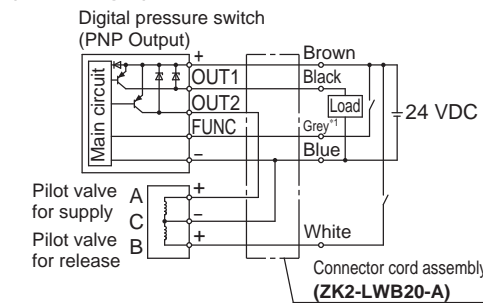

*1 The grey wire (FUNC) is connected when operating the supply valve by energy saving control (for workpiece adsorption). (For details, refer to the Operation Manual for the ZK2-ZSV□□□-A on the SMC website.)

Supply Valve/Release Valve

Valve type K/R (With supply valve/release valve)

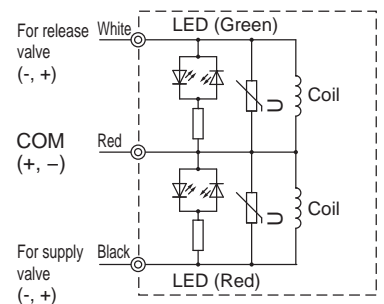

Valve type J (With supply valve/Without release valve)

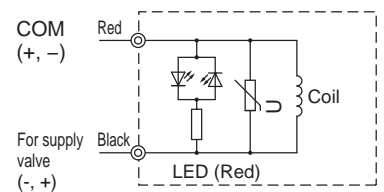

- PV: Air pressure supply port/Port for vacuum source (Vacuum pump)
 - PS: Pilot pressure supply port
 - PD: Release pressure supply port
 - V: Vacuum port
 - EXH: Exhaust port
 - PE: Pilot pressure exhaust port
- For details ⇒ Page 30

Port Layout

* System depends on vacuum source (vacuum pump/ejector).

Standard Products

Port layout No. **1**

Single unit: ZK2P00□□□□A-□

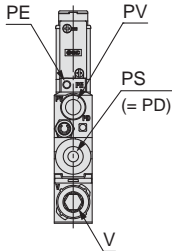

System	Vacuum pump	
Body type	Single unit	
Exhaust type	Without silencer	
Application and purpose	Vacuum pressure	—
	Exhaust	—
	Release pressure	Same pressure as PS

Port combination: PV ≠ PS = PD

Circuit example

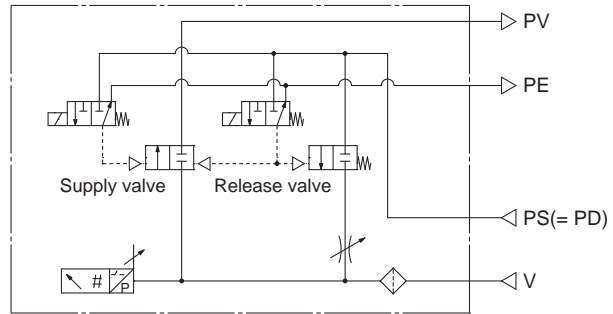

Supply valve: Self-holding type (R type) Release valve: N.C.

Port layout No. **2**

Single unit: ZK2Q00□□□□A-□
Manifold: ZZK2□□A-P2□

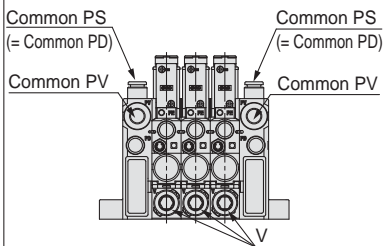

System	Vacuum pump	
Body type	Manifold	
Exhaust type	Without silencer	
Application and purpose	Vacuum pressure	Common for each station
	Exhaust	—
	Release pressure	Same pressure as common PS

Port combination: Common PV ≠ Common PS = Common PD

Circuit example

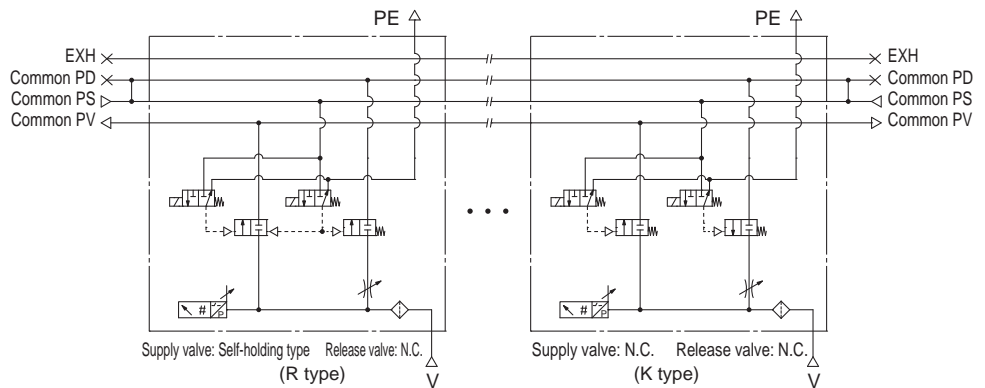

Supply valve: Self-holding type (R type) Release valve: N.C.

Supply valve: N.C. Release valve: N.C. (K type)

Port layout No. **3**

Single unit: ZK2A□□□□□□A-□

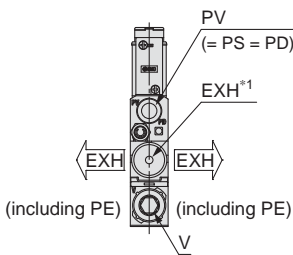

System	Ejector	
Body type	Single unit	
Exhaust type	Silencer exhaust	
Application and purpose	Vacuum pressure	—
	Exhaust	Released in operating environment
	Release pressure	Same pressure as PV

Port combination: PV = PS = PD

Circuit example

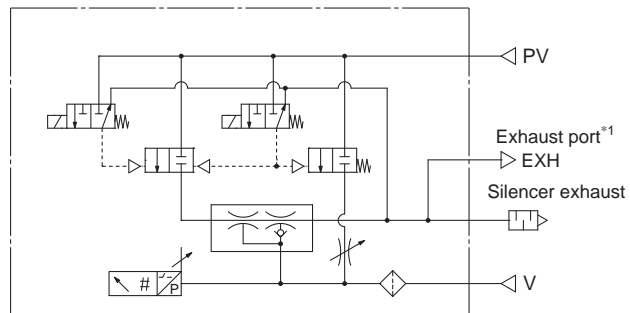

Supply valve: Self-holding type (R type) Release valve: N.C.

*1 Nozzle size: 12, 15

Refer to page 30 for the purpose of port and the operating pressure range.

- PV: Air pressure supply port/Port for vacuum source (Vacuum pump)
 - PS: Pilot pressure supply port
 - PD: Release pressure supply port
 - V: Vacuum port
 - EXH: Exhaust port
 - PE: Pilot pressure exhaust port
- For details ⇒ Page 30

Port Layout

* System depends on vacuum source (vacuum pump/ejector).

Standard Products

Port layout No. **4**

Single unit: ZK2B□□□□□□A-□

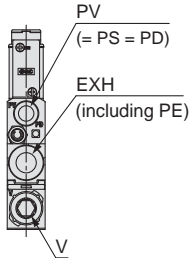

System	Ejector
Body type	Single unit
Exhaust type	Port exhaust
Application and purpose	Vacuum pressure
	Exhaust
	Release pressure

After piping, individual exhaust is necessary.
Same pressure as PV

Port combination: PV = PS = PD

Circuit example

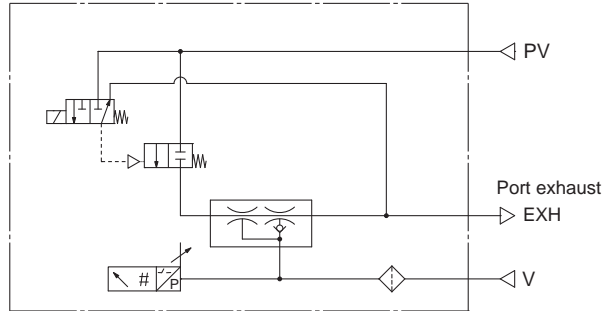

Supply valve: N.C. Release valve: Without release valve (J type)

Port layout No. **5**

Single unit: ZK2G□□□□□□A-□

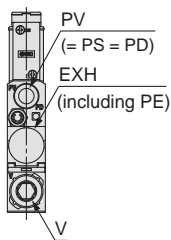

System	Ejector
Body type	Single unit
Exhaust type	High-noise reduction silencer exhaust
Application and purpose	Vacuum pressure
	Exhaust
	Release pressure

Released in operating environment
Same pressure as PV

Port combination: PV (= PS = PD)

Circuit example

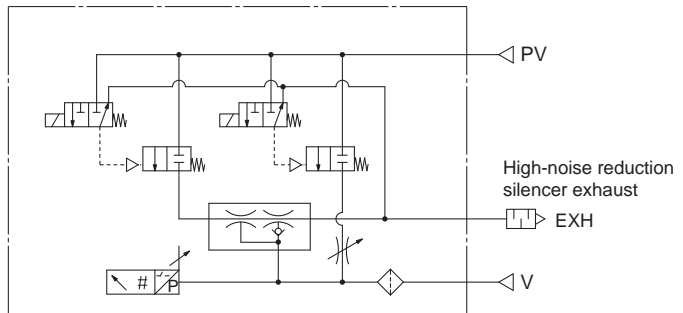

Supply valve: N.C. Release valve: N.C. (K type)

Port layout No. **6**

Single unit: ZK2C□□□□□□A-□
Manifold: ZZK2□□□□A-A1□

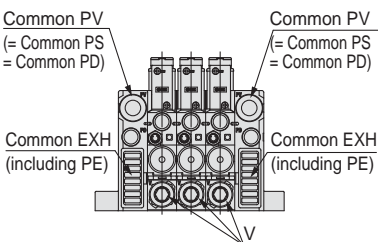

*1 The complex exhaust is a combined exhaust method of the common exhaust from the end plate and the direct exhaust from each station.

System	Ejector
Body type	Manifold
Exhaust type	Complex exhaust*1
Application and purpose	Vacuum pressure
	Exhaust
	Release pressure

Common for each station
Released in operating environment
Same pressure as common PV

Port combination: Common PV = Common PS = Common PD

Circuit example

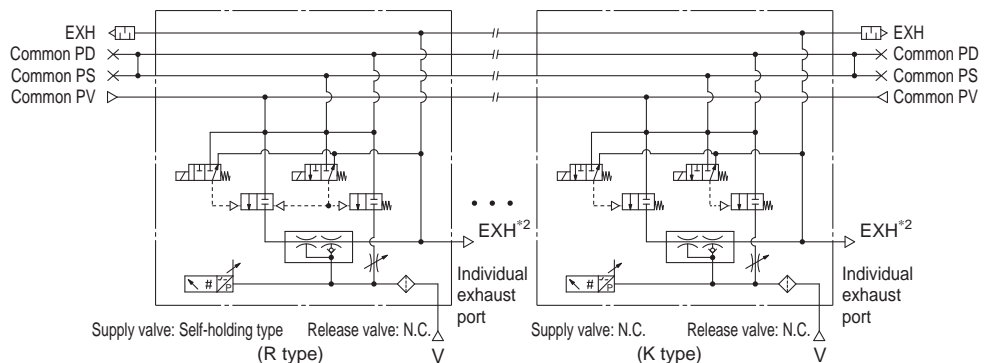

*2 For complex exhaust type, individual exhaust port is provided to each station.

Refer to page 30 for the purpose of port and the operating pressure range.

- PV: Air pressure supply port/Port for vacuum source (Vacuum pump)
 - PS: Pilot pressure supply port
 - PD: Release pressure supply port
 - V: Vacuum port
 - EXH: Exhaust port
 - PE: Pilot pressure exhaust port
- For details ⇒ Page 30

Port Layout

* System depends on vacuum source (vacuum pump/ejector).

Standard Products

Port layout No. **7**

Single unit: **ZK2F□□□□□A-□**
 Manifold: **ZZK2□□A-A2□**

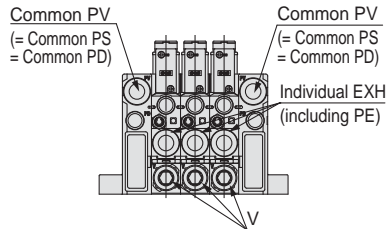

System	Ejector	
Body type	Manifold	
Exhaust type	Individual port exhaust	
Application and purpose	Vacuum pressure	Common for each station
	Exhaust	After piping, individual exhaust is necessary.
	Release pressure	Same pressure as common PV

Port layout No. **8**

Single unit: **ZK2H□□□□□A-□**
 Manifold: **ZZK2□□A-A2□**

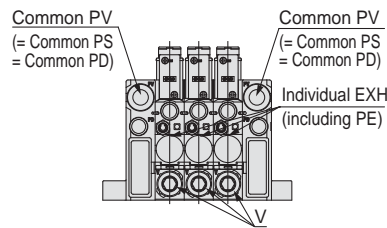

System	Ejector	
Body type	Manifold	
Exhaust type	High-noise reduction silencer exhaust	
Application and purpose	Vacuum pressure	Common for each station
	Exhaust	Released in operating environment
	Release pressure	Same pressure as common PV

Port combination: Common PV = Common PS = Common PD

Circuit example

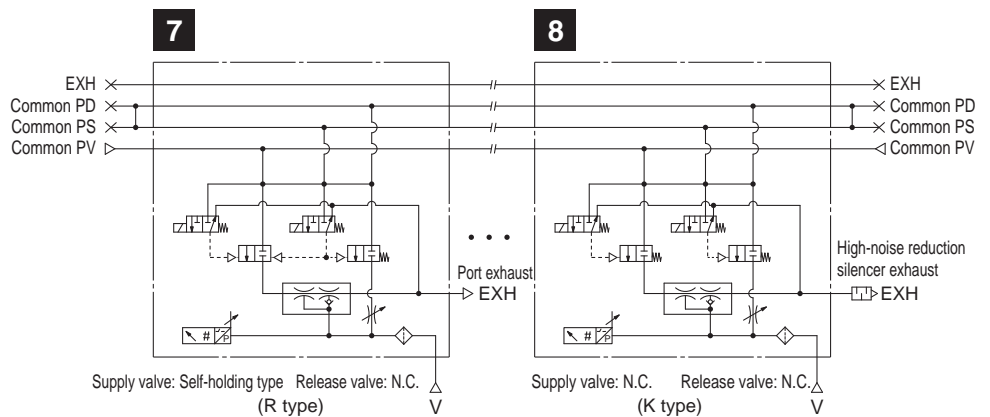

Option -D

Port layout No. **9**

Single unit: **ZK2P00□□□□A-□-D**

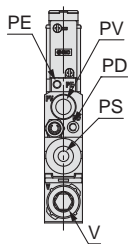

System	Vacuum pump	
Body type	Single unit	
Exhaust type	Without silencer	
Application and purpose	Vacuum pressure	—
	Exhaust	—
	Release pressure	PD pressure has to be supplied with PS pressure.

Port combination: PV ≠ PS ≠ PD

Circuit example

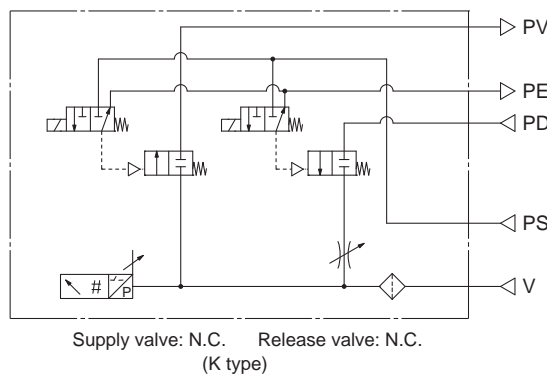

Refer to page 30 for the purpose of port and the operating pressure range.

- PV: Air pressure supply port/Port for vacuum source (Vacuum pump)
 - PS: Pilot pressure supply port
 - PD: Release pressure supply port
 - V: Vacuum port
 - EXH: Exhaust port
 - PE: Pilot pressure exhaust port
- For details ⇒ Page 30

Port Layout

* System depends on vacuum source (vacuum pump/ejector).

Option -D

Port layout No. **10**

Single unit: ZK2Q00□□□□A-□
Manifold: ZZK2□□A-P2□-D

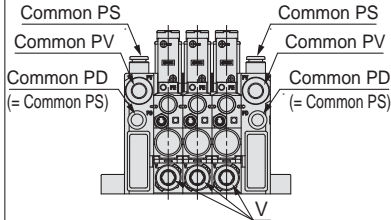

System	Vacuum pump	
Body type	Manifold	
Exhaust type	Without silencer	
Application and purpose	Vacuum pressure	Common for each station
	Exhaust	—
	Release pressure	Common PD pressure has to be supplied with common PS.

Port combination: Common PV ≠ Common PS ≠ Common PD

Circuit example

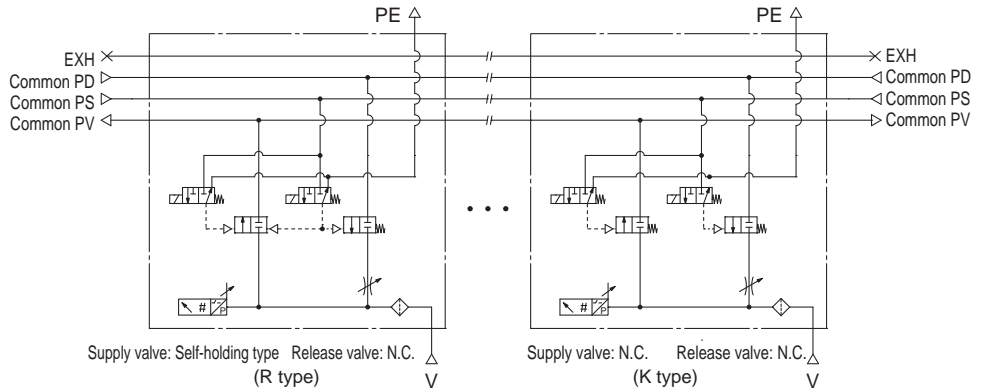

Port layout No. **11**

Single unit: ZK2A□□□□□□A-□-D

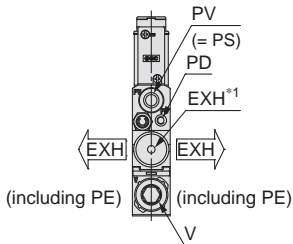

System	Ejector	
Body type	Single unit	
Exhaust type	Silencer exhaust	
Application and purpose	Vacuum pressure	—
	Exhaust	Released in operating environment
	Release pressure	PD pressure has to be supplied with PV pressure.

Port combination: PV = PS ≠ PD

Circuit example

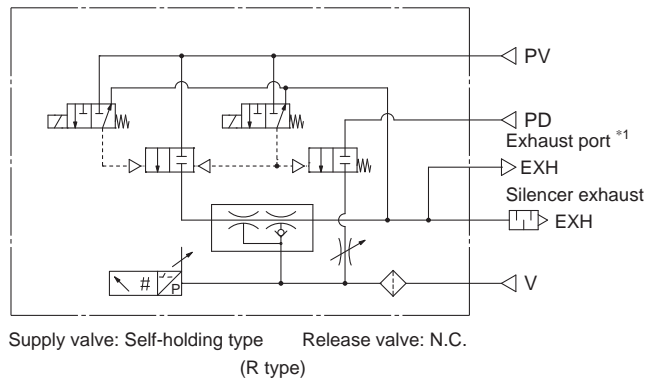

*1 Nozzle size: 12, 15

Port layout No. **12**

Single unit: ZK2B□□□□□□A-□-D

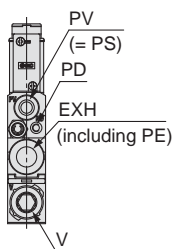

System	Ejector	
Body type	Single unit	
Exhaust type	Port exhaust	
Application and purpose	Vacuum pressure	—
	Exhaust	After piping, individual exhaust is necessary.
	Release pressure	PD pressure has to be supplied with PV pressure.

Port combination: PV = PS ≠ PD

Circuit example

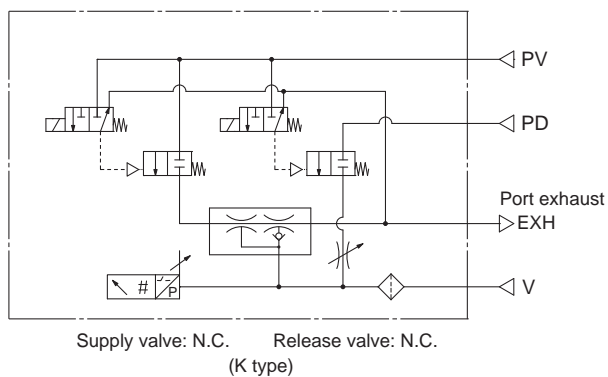

Refer to page 30 for the purpose of port and the operating pressure range.

- PV: Air pressure supply port/Port for vacuum source (Vacuum pump)
 - PS: Pilot pressure supply port
 - PD: Release pressure supply port
 - V: Vacuum port
 - EXH: Exhaust port
 - PE: Pilot pressure exhaust port
- For details ⇒ Page 30

Port Layout

* System depends on vacuum source (vacuum pump/ejector).

Option -D

Port layout No. **13**

Single unit: **ZK2G□□□□□A-□-D**

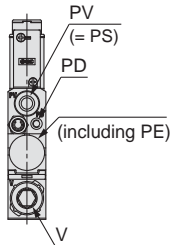

System	Ejector
Body type	Single unit
Exhaust type	High-noise reduction silencer exhaust
Vacuum pressure	—
Application and purpose	Exhaust
Release pressure	Released in operating environment
	PD pressure has to be supplied with PV pressure.

Port combination: **PV = PS ≠ PD**

Circuit example

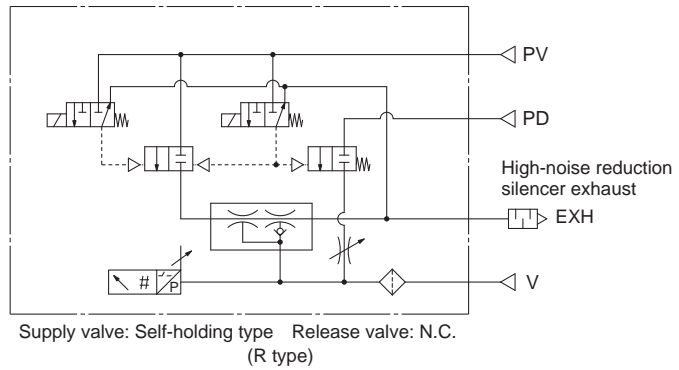

Port layout No. **14**

Single unit: **ZK2C□□□□□A-□-P**
Manifold: **ZZK2□□A-A1□-D**

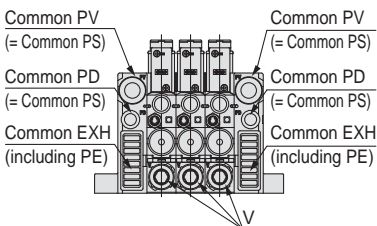

*1 The complex exhaust is a combined exhaust method of the common exhaust from the end plate and the direct exhaust from each station.

System	Ejector
Body type	Manifold
Exhaust type	Complex exhaust*1
Vacuum pressure	Common for each station
Application and purpose	Exhaust
Release pressure	Released in operating environment
	Common PD pressure has to be supplied with common PV.

Port combination: **Common PV = Common PS ≠ Common PD**

Circuit example

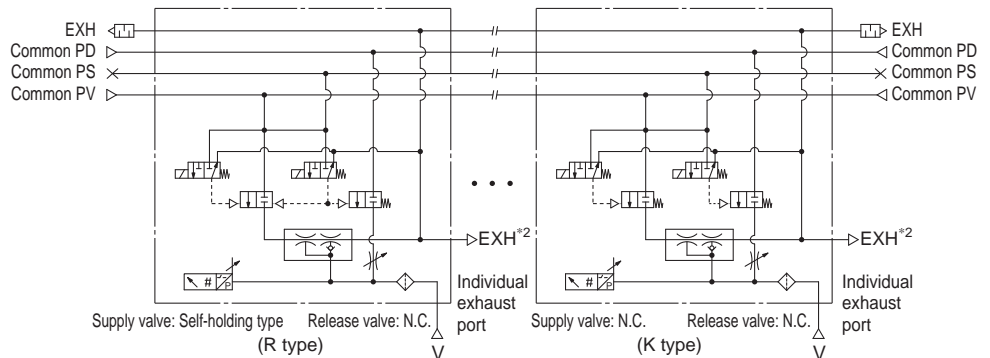

*2 For complex exhaust type, individual exhaust port is provided to each station.

Port layout No. **15**

Single unit: **ZK2F□□□□□A-□-P**
Manifold: **ZZK2□□A-A2□-D**

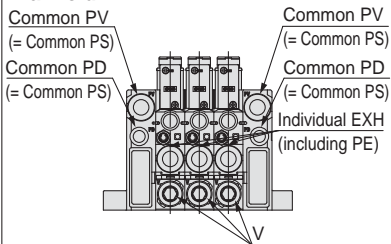

System	Ejector
Body type	Manifold
Exhaust type	Individual port exhaust
Vacuum pressure	Common for each station
Application and purpose	Exhaust
Release pressure	After piping, individual exhaust is necessary.
	Common PD pressure has to be supplied with common PV.

Port combination: **Common PV = Common PS ≠ Common PD**

Circuit example

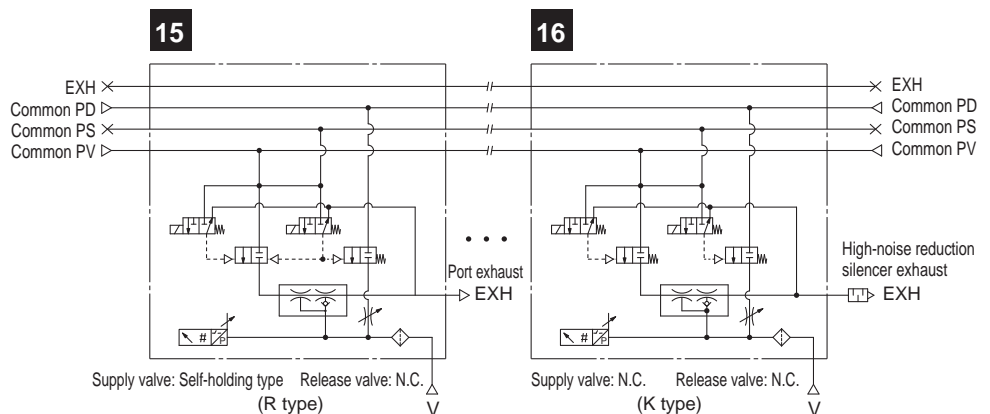

Refer to page 30 for the purpose of port and the operating pressure range.

ZK2□A Series

- PV: Air pressure supply port/Port for vacuum source (Vacuum pump)
 - PS: Pilot pressure supply port
 - PD: Release pressure supply port
 - V: Vacuum port
 - EXH: Exhaust port
 - PE: Pilot pressure exhaust port
- For details ⇒ Page 30

Port Layout

* System depends on vacuum source (vacuum pump/ejector).

Option -D

Port layout No. **16**

Single unit: ZK2H□□□□□□A-□-P
Manifold: ZZK2□□A-A2□-D

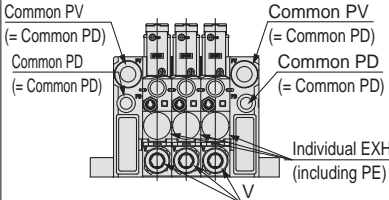

System	Ejector
Body type	Manifold
Exhaust type	High-noise reduction silencer exhaust
Application and purpose	Vacuum pressure: Common for each station
Exhaust	Released in operating environment
Release pressure	PD pressure has to be supplied with PV pressure.

Port combination: Common PV = Common PS ≠ Common PD

Circuit example

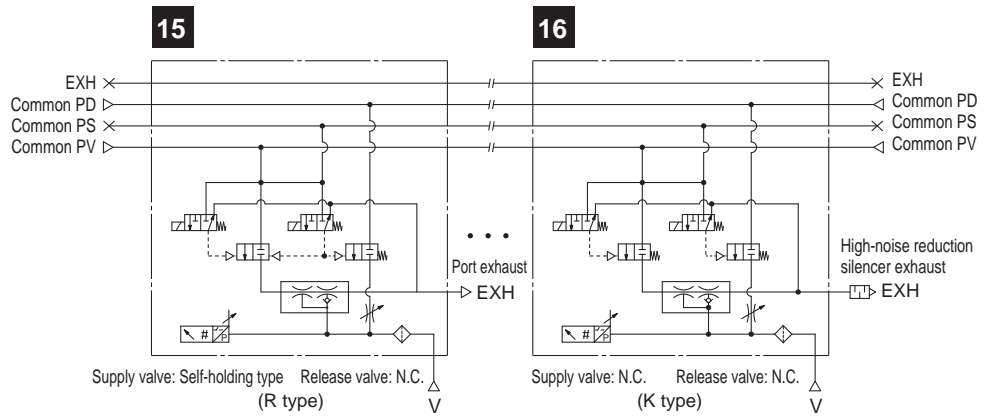

Option -L

Port layout No. **17**

Single unit: ZK2C□□□□□□A-□-L
Manifold: ZZK2□□A-A1□-L

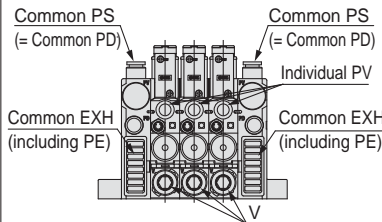

*1 The complex exhaust is a combined exhaust method of the common exhaust from the end plate and the direct exhaust from each station.

System	Ejector
Body type	Manifold
Exhaust type	Complex exhaust*1
Application and purpose	Vacuum pressure: PV pressure can be changed per station.
Exhaust	Released in operating environment
Release pressure	Same pressure for common PS and common PD

Port combination: Individual PV ≠ Common PS = Common PD

Circuit example

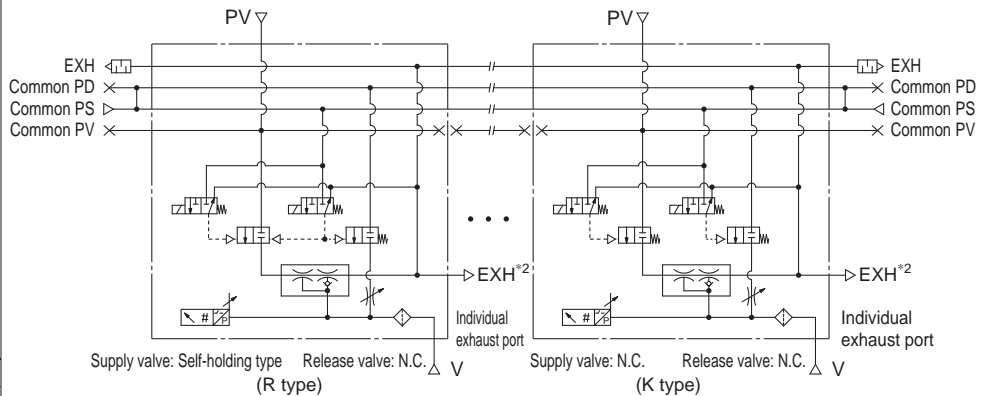

Port layout No. **18**

Single unit: ZK2F□□□□□□A-□-L
Manifold: ZZK2□□A-A2□-L

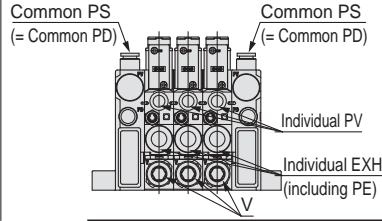

System	Ejector
Body type	Manifold
Exhaust type	Individual port exhaust
Application and purpose	Vacuum pressure: PV pressure can be changed per station.
Exhaust	After piping, individual exhaust is necessary.
Release pressure	Same pressure for common PS and common PD

Port combination: Individual PV ≠ Common PS = Common PD

Circuit example

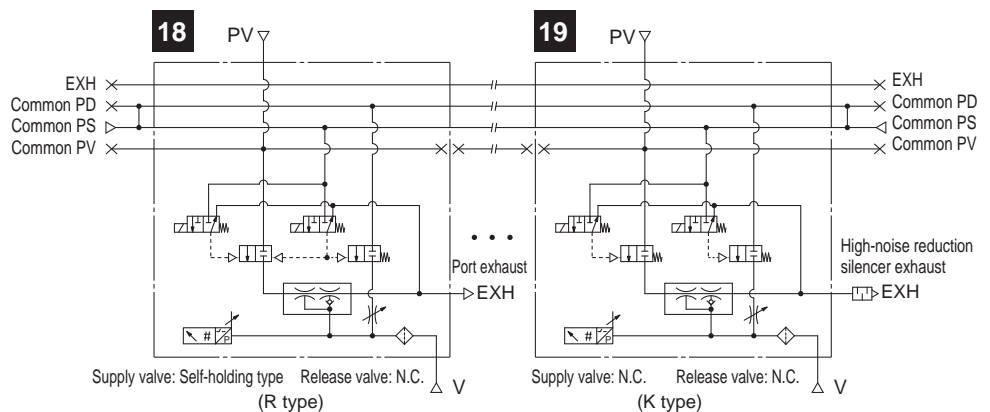

Refer to page 30 for the purpose of port and the operating pressure range.

- PV: Air pressure supply port/Port for vacuum source (Vacuum pump)
 - PS: Pilot pressure supply port
 - PD: Release pressure supply port
 - V: Vacuum port
 - EXH: Exhaust port
 - PE: Pilot pressure exhaust port
- Refer to the table below for details.

Port Layout

* System depends on vacuum source (vacuum pump/ejector).

Option -L

Port layout No. **19**

Single unit: ZK2H□□□□□A-□-L
Manifold: ZZK2□□A-A2□-L

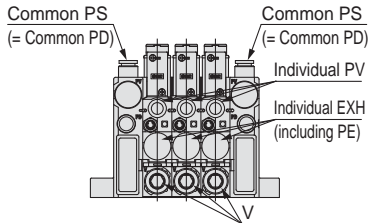

System	Ejector	
Body type	Manifold	
Exhaust type	High-noise reduction silencer exhaust	
Application and purpose	Vacuum pressure	PV pressure can be changed per station.
	Exhaust	Released in operating environment
	Release pressure	Same pressure for common PS and common PD

Port combination: Individual PV ≠ Common PS = Common PD

Circuit example

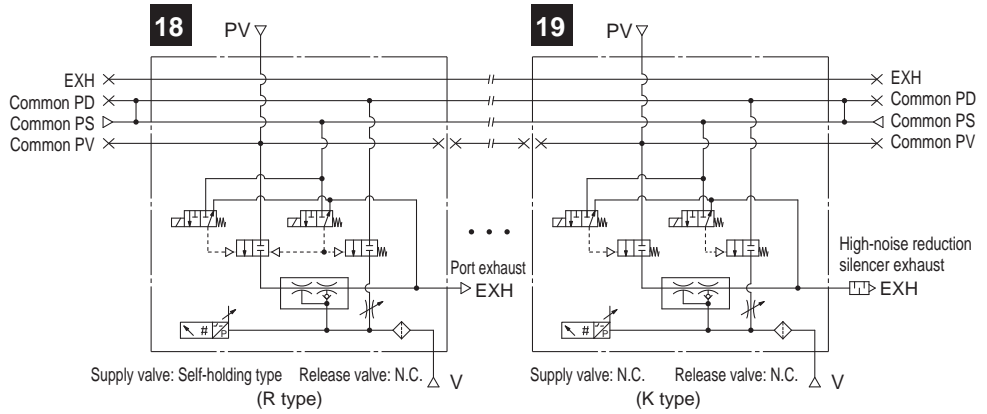

Application and Operating Pressure Range of Each Port

Port	Description	Ejector system	Vacuum pump system
PV	Air pressure supply port (Operating pressure range)	Compressed air supply for operating ejector 0.3 to 0.6 MPa*1, *2	—
	Vacuum pressure supply port (Operating pressure range)	—	Vacuum source (Vacuum pump) 0 to -100 kPa
PS	Pilot pressure supply port (Operating pressure range)	—	Compressed air supply for pilot valve 0.3 to 0.6 MPa
PD	Individual release pressure supply port (Operating pressure range)	Release pressure Compressed air supply for individual setting (Option) 0 to 0.6 MPa (PD ≤ PV)	0 to 0.6 MPa (PD ≤ PS)
V	Vacuum port	For connecting adsorption equipment including pad	
EXH	Exhaust port	Exhaust when ejector operates*3	—
PE	Pilot pressure exhaust port	Exhaust when valve operates*4	

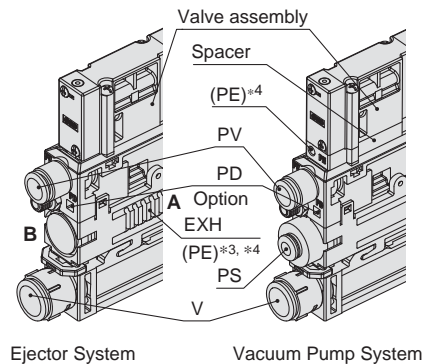

- *1 For models without valve, pressure can be 0.3 MPa or less. (Ejector system)
 - *2 Manifold can be used at 0.3 MPa or less when the manifold is for individual SUP. For 0.2 MPa or less, select K or J for the valve type. Set pressure as PV ≤ PS.
 - *3 For ejectors with silencer, air exhausts from A (slit on both sides). For port exhaust type, air exhausts from B.
 - *4 Pilot pressure for ejectors is exhausted from the ejector and the common exhaust. Vacuum pump system exhausts air from PE port on the spacer. Female thread type (M3) is available by option [C] for PE port of the vacuum pump system. When option [C] is selected for valve type R, operating conditions below apply.
 - Select the type with release pressure supply port (PD) as an option.
 - Single unit/Manifold: Option [D]
 - For Manifold: Option [P]
 - Vacuum pressure for PV port: -60 to -100 kPa
 - The energisation time of the release valve: 200 ms or longer when the PD port is released to the atmosphere
500 ms or longer when the 0.1 MPa is supplied to the PD port
- If the product is used out of this operating condition, please contact your local sales office.

Construction

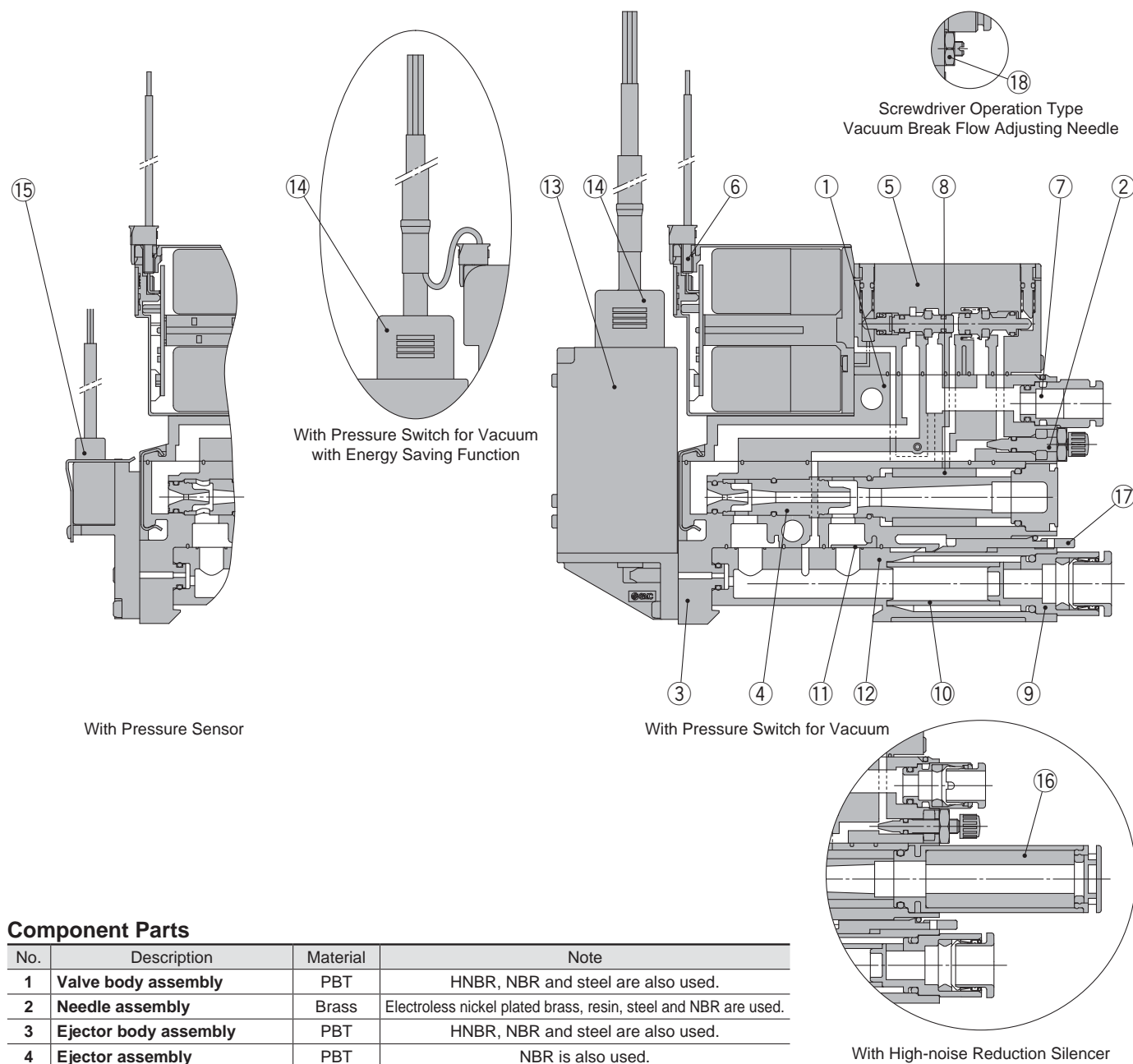

Component Parts

No.	Description	Material	Note
1	Valve body assembly	PBT	HNBR, NBR and steel are also used.
2	Needle assembly	Brass	Electroless nickel plated brass, resin, steel and NBR are used.
3	Ejector body assembly	PBT	HNBR, NBR and steel are also used.
4	Ejector assembly	PBT	NBR is also used.

Replacement Parts

No.	Description	Note
5	Valve assembly	—
6	Connector assembly	Connector for solenoid valve 3 wire (For valve type K/R), 2 wire (For valve type J)
7	One-touch fitting assembly	Metric size: Ø 6, Inch size: Ø 1/4"
8	Sound absorbing material	10 pcs. per set
9	Vacuum port adapter assembly	With One-touch fitting and filter element
10	Filter element	Nominal filtration rating: 30 µm, 10 pcs. per set
11	Body gasket	Gasket integrated with the exhaust interference prevention valve, 10 pcs. per set
12	Filter case	Case body: Polycarbonate (Refer to the Specific Product Precautions on page 47.) Clear filter case: without a port for the pressure switch or sensor, Opaque filter case: with a port for the pressure switch or sensor
13	Vacuum pressure switch assembly	With 2 screws and 1 gasket
14	Lead wire with connector	—
15	Pressure sensor assembly	With 2 screws and 1 gasket
16	High-noise reduction silencer case assembly	With sound absorbing material (Part number: ZK2-SE4-6-A)
17	Release lever	10 pcs. per set
18	Lock nut	10 pcs. per set

Replacement Parts for Single Unit / How to Order

Valve assembly

▶ p. 31 Construction ⑤

ZK2 - VA **A** **K** **5** **L** A - A

① ② ③ ④

① Applicable system

A	Ejector system
P	Vacuum pump system

② Valve type

K	Supply valve: N.C., Release valve: N.C.
R	Supply valve: Self-holding release valve linked, Release valve: N.C.
J	Supply valve: N.C., Release valve: None

③ Rated voltage

5	24 VDC
6	12 VDC

④ Wiring

C	Manifold common wiring
L	Individual wiring: With connector assembly (Lead wire length: 300 mm)
LO	Individual wiring: Without connector assembly

Select the ZK2-VAAK5LOA-A for a switch with energy saving function.

Connector assembly

▶ p. 31 Construction ⑥

ZK2 - LV **W** □ - A

Applicable valve type

W	Valve type K/R
S	Valve type J

Lead wire length

—	300 mm
6	600 mm
10	1000 mm
20	2000 mm
30	3000 mm

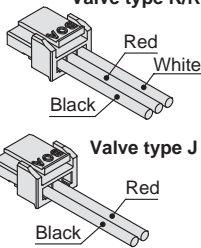

One-touch fitting assembly (Purchasing order is available in units of 10 pieces.)

KJH **06** - C2

▶ p. 31 Construction ⑦

Port size

06	∅ 6 One-touch fitting (Straight)	Metric size
07	∅ 1/4" One-touch fitting (Straight)	Inch size

Sound absorbing material (10 pcs. per set)

▶ p. 31 Construction ⑧

ZK2 - SE1 - **1** - A

Sound absorbing material hole diameter

1	300 μm
----------	--------

Vacuum port adapter assembly (Purchasing order is available in units of 1 piece.)

ZK2 - VA1S **8** - A

▶ p. 31 Construction ⑨

One-touch fitting size

6	∅ 6 One-touch fitting	Metric size
8	∅ 8 One-touch fitting	Metric size
7	∅ 1/4" One-touch fitting	Inch size
9	∅ 5/16" One-touch fitting	Inch size

Filter element (10 pcs. per set)

▶ p. 31 Construction ⑩

ZK2 - FE1 - **3** - A

Nominal filtration rating

3	30 μm
----------	-------

Body gasket*¹ (10 pcs. per set)

▶ p. 31 Construction ⑪

ZK2 - BG5 - **1** - A

Applicable type

1	One check valve type (All specifications other than vacuum switch with energy saving function and exhaust interference prevention valve)
2	Two check valve type (Vacuum switch with energy saving function and exhaust interference prevention valve)

*1 When ZK2-BG5-2-A is mounted, the workpiece cannot be removed until vacuum is released.

Filter case

▶ p. 31 Construction ⑫

ZK2 - FC □ - A

Port for the pressure switch or sensor

Symbol	Port for the pressure switch or sensor	Filter case colour
P	With port (type with pressure switch or sensor)	Smoke
T	Without port (type without pressure switch or sensor)	Clear

Pressure switch for vacuum assembly (With 2 mounting screws)

ZK2 - ZS **E** **B** **M** **G** □ - A

▶ p. 31 Construction ⑬

① ② ③ ④ ⑤

① Rated pressure range and function

E	-101 to 0 kPa	Pressure switch for vacuum	Open collector 2 outputs
F	-100 to 100 kPa	Pressure switch for vacuum	Open collector 2 outputs
V	-100 to 100 kPa	Pressure switch for vacuum with energy saving function	Open collector 1 output

② Output

A	NPN
B	PNP

③ Unit

—	Unit selection function
M	SI unit only* ¹

*1 Fixed unit: kPa

④ Lead wire with connector

—	None	
G	With lead wire	When ① is E or F...For pressure switch for vacuum, Lead wire with connector (Length 2 m)
	With lead wire	When ① is V...For pressure switch for vacuum with energy saving function, Lead wire with connector (Length 2 m)

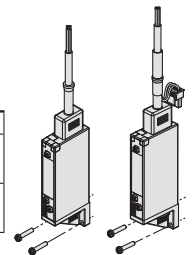

⑤ Mounting*³

—	Mounted to the single unit
L	Mounted to the manifold

The length of the mounting screw ejector included in the package is different.

*3 When ordering an ejector without valve, select — for mounting.

Lead wire with connector

▶ p. 31 Construction ⑭

(When individual lead wire is necessary, order with the port number below.)

- Lead wire with connector for pressure switch for vacuum **ZS - 39 - 5G**
- Lead wire with connector for pressure switch for vacuum with energy saving function **ZK2 - LW **B** 20 - A**

Output

A	NPN open collector
B	PNP open collector

Pressure sensor assembly (With 2 mounting screws)

▶ p. 31 Construction ⑮

ZK2 - PS **1** □ - A

Rated pressure range

1	0 to -101 kPa, Output: 1 to 5 V, Accuracy: ± 2 % F.S.
3	-100 to 100 kPa, Output: 1 to 5 V, Accuracy: ± 2 % F.S.

Mounting*⁴

—	Mounted to the single unit
L	Mounted to the manifold

The length of the mounting screw ejector included in the package is different.

*4 When ordering an ejector without valve, select — for mounting.

High-noise reduction silencer case assembly

▶ p. 31 Construction ⑯

ZK2 - SC3 - **4** - A

Applicable nozzle size

4	For nozzle size 07, 10
6	For nozzle size 12, 15

Release lever (10 pcs. per set)

▶ p. 31 Construction ⑰

ZK2 - RL1 - A

Round lock (10 pcs. per set)

▶ p. 31 Construction ⑱

ZK2 - LN1 - A

Vacuum Unit/ZK2□A Series

Exploded View of Manifold

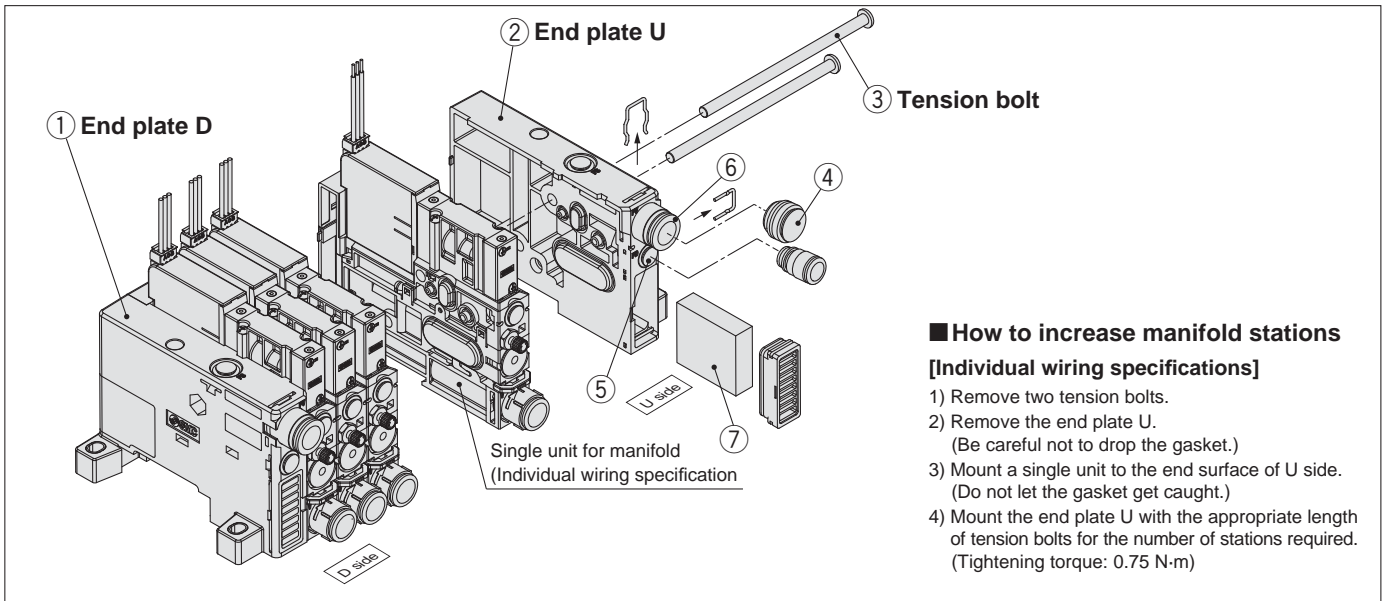

How to increase manifold stations [Individual wiring specifications]

- 1) Remove two tension bolts.
- 2) Remove the end plate U.
(Be careful not to drop the gasket.)
- 3) Mount a single unit to the end surface of U side.
(Do not let the gasket get caught.)
- 4) Mount the end plate U with the appropriate length of tension bolts for the number of stations required.
(Tightening torque: 0.75 N·m)

Component Parts

No.	Description	Material	Note
1	End plate D assembly	Resin	HNBR, NBR and steel are also used.
2	End plate U assembly	Resin	Electroless nickel plated brass, resin, steel and NBR are used.

Replacement Parts

No.	Description	Note
3	Tension bolt assembly	2 pcs. per set
4	Port plug assembly	Plug for changing PV port to single side supply type (Common for mm and inch type)
5	Port plug assembly	Plug for changing PS or PD port to single side supply type (Common for mm and inch type)
6	One-touch fitting assembly	Metric size: Ø 8, Inch size: Ø 5/16"
7	Sound absorbing material	2 pcs. per set - Material: Non-woven cloth (Silencer cover is not included.)
8	DIN rail	Refer to Dimensions (Refer to pages 39 to 41) for the recommended length for each number of manifolds stations.
9	Connector housing assembly	Available connector is even number only. (If you need a connector for odd number, specify the connector of the number you need + 1 station.)

Replacement Parts for Manifold / How to Order

Manifold end plate assembly

▶ Exploded View ①, ②, ③

Assembly number including ①End plate D, ②End plate U and ③Tension bolt assembly (Used for the maintenance of the end plate)

ZK2 - A

● Manifold end plate assembly

Refer to pages 14 and 17 for the manifold part number.

Tension bolt assembly (2 pcs. per set)

▶ Exploded View ③

ZK2 - TB1 - 05 - A

● Applicable stations

01	For 1 station manifold
⋮	⋮
10	For 10 stations manifold

Port plug assembly

▶ Exploded View ④

(Purchasing order is available in units of 1 piece.)

VVQZ2000 - CP

Port plug assembly

▶ Exploded View ⑤

(Purchasing order is available in units of 1 piece.)

ZK2 - MP1C6 - A

One-touch fitting assembly (Purchasing order is available in units of 10 pieces.)

VVQ1000 - 51A - C8

▶ Exploded View ⑥

● Port size

C8	Ø 8 One-touch fitting
N9	Ø 5/16" One-touch fitting

Sound absorbing material (2 pcs. per set)

▶ Exploded View ⑦

ZK2 - SE2 - 1 - A

DIN rail

AXT100 - DR - 5

● Length symbol

1 to 40
L = 23 to L = 510.5

[L = 12.5 × + 10.5]
■: Length symbol 1 to 40

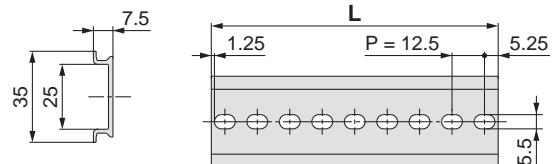

* When selecting the number, refer to "L6" in dimension table on pages 39 to 41.

L Dimensions

No.	1	2	3	4	5	6	7	8	9	10
L Dimension	23	35.5	48	60.5	73	85.5	98	110.5	123	135.5
No.	11	12	13	14	15	16	17	18	19	20
L Dimension	148	160.5	173	185.5	198	210.5	223	235.5	248	260.5
No.	21	22	23	24	25	26	27	28	29	30
L Dimension	273	285.5	298	310.5	323	335.5	348	360.5	373	385.5
No.	31	32	33	34	35	36	37	38	39	40
L Dimension	398	410.5	423	435.5	448	460.5	473	485.5	498	510.5

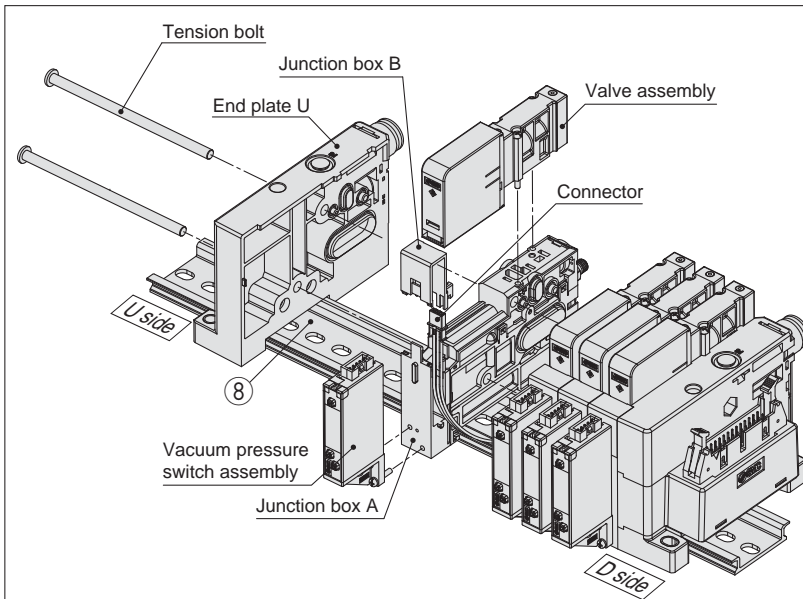

■ How to increase manifold stations

[To increase the number of stations from odd number (1, 3, 5, 7, 9) in common wiring type to even number (2, 4, 6, 8, 10)]

(Common wiring of odd number station has a vacant connector for one station. Easy to add a station.)

- 1) Remove the tension bolt.
- 2) Remove the end plate U.
- 3) Remove the valve assembly of a single unit for extra station(s) for manifold.
- 4) Remove the switch assembly if it is present. (Be careful not to drop the O-ring. Refer to **Fig.1**)
- 5) Remove the junction box B (top) using a precision screwdriver. (Refer to **Fig.2**)
- 6) Mount the extra connector to the junction box B. (Refer to **Fig.3**) (Engage the recess of the connector and the protrusion of the junction box B. (Refer to **Fig.3-A**))
- 7) Mount a single unit for extra station(s) for manifold to the end surface of U side. (Do not let the gasket or lead wire get caught.)
- 8) Mount the end plate U with the appropriate length of tension bolts for the number of stations required. (Tightening torque: 0.75 N·m.)
- 9) Mount the junction box B to the junction box A.
- 10) Assemble the valve assembly. (Tightening torque: 0.15 N·m)
- 11) For products with a switch, mount the switch assembly. (Be careful not to drop the O-ring. Tightening torque: 0.08 to 0.10 N·m)

[To increase the number of stations from even number to odd number, or increase two stations or more]

- 1) Remove the valve assembly for all stations. (Single unit for extra station is also removed.)
- 2) Remove the switch assembly if it is present. (Be careful not to drop the O-ring. Refer to **Fig.1**)
- 3) Remove the junction box B (top) for all stations using a precision screwdriver. (Refer to **Fig.2**) (Remove the junction box B from D side.)
- 4) Remove all connectors mounted to the junction box B. (Be careful not to break the connector clip.)
- 5) Remove the tension bolt.
- 6) Remove the end plate D assembly.
- 7) Remove the connector housing assembly from the end plate D assembly. (Refer to **Fig.4**)
- 8) Mount the connector housing assembly for extra station(s) to the end plate D assembly. (Refer to **Fig.4**) (Insert two clips of the housing mounting surface to the square holes of the end plate, and slide the connector housing assembly.)
- 9) Remove the end plate U. (Be careful not to drop the gasket.)
- 10) Mount a single unit for extra station(s) for manifold to the end surface of U side. Do not let the gasket get caught.
- 11) Mount the end plate U and D with the appropriate length of tension bolts for the number of stations required. (Tightening torque: 0.75 N·m.)
- 12) Mount the connector for all stations to the junction box B. (Refer to **Fig.3**) (Engage the recess of the connector and the protrusion of the junction box B. (Refer to **Fig.3-A**))
- 13) Mount the junction box A to the junction box B.
Push the wires down the side and mount the junction box A to the junction box B following a decreasing mark tube numbers from U side. (Do not let the lead wire get caught.)
- 14) Assemble the valve assembly. (Tightening torque: 0.15 N·m)
- 15) For products with a switch, mount the switch assembly. (Be careful not to drop the O-ring. Tightening torque: 0.08 to 0.10 N·m)

*1 When adding a vacuum pump system, the vacuum pump spacer for extra station is required separately.

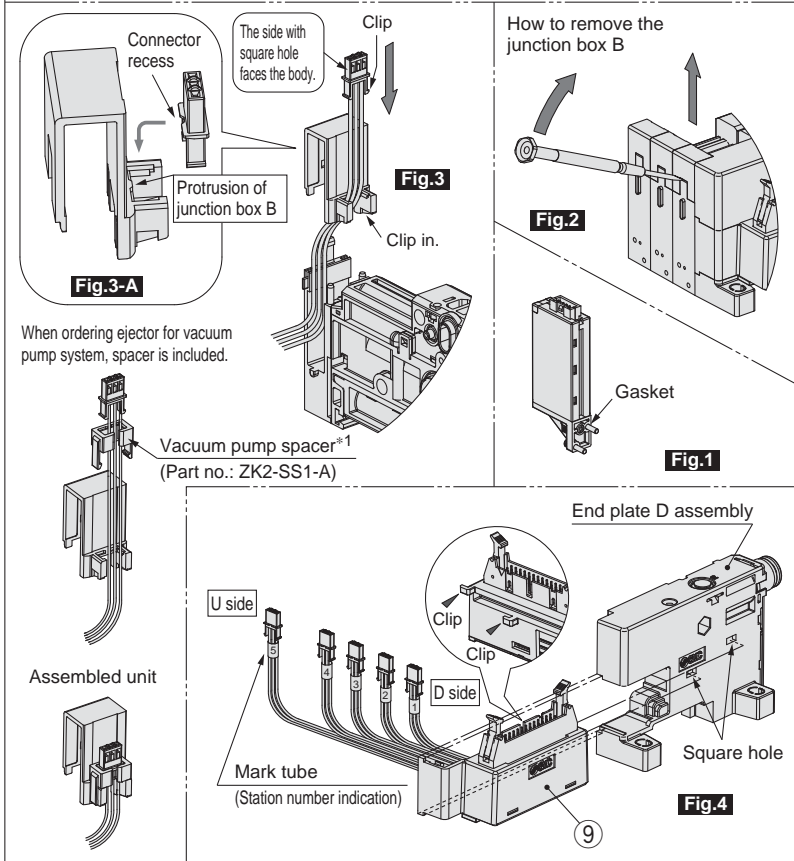

Connector housing assembly ▶ Exploded View ⑨

ZK2-CH 2 04 - A

● Applicable stations

02	For 2 stations manifold
04	For 4 stations manifold
06	For 6 stations manifold
08	For 8 stations manifold
10	For 10 stations manifold

● Connector type

1	D sub-connector (25 pins)
2	Flat ribbon cable connector (26 pins)

■ Plug (For One-touch fitting) (Purchasing order is available in units of 10 pieces.)

Mounted onto ports which are not used (PV, PS, PD, etc.)

KQ2P-06

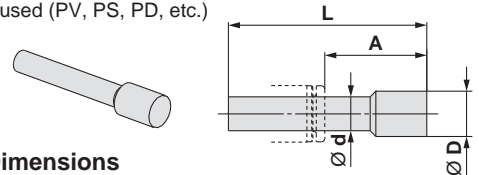

● Models and Dimensions

Symbol	Applicable size Ø d	A	L	Ø D	Weight [g]	Note
06	Ø 6	18	35	8	1	White
08	Ø 8	20.5	39	10	2	White
07	Ø 1/4"	18	35	8.5	1	Orange
09	Ø 5/16"	20.5	39	10	2	Orange

ZK2□A Series

Dimensions: Single Unit

ZK2^A_B□_R□NL2A-□

Ejector system, Single unit, With supply valve/release valve, Without pressure sensor/switch

For high-noise reduction silencer exhaust

For screwdriver operation type long lock nut

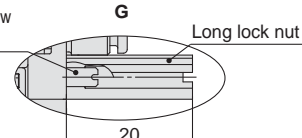
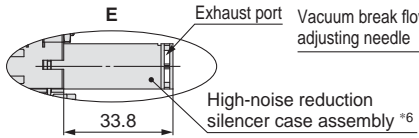

For port exhaust

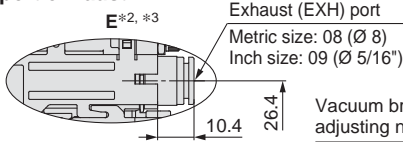

- *1 For silencer exhaust type, air is exhausted from the slit on both sides. (Do not cover both sides. Release at least one side.)
- *2 For port exhaust type, air is exhausted from the One-touch fitting.
- *3 Pilot pressure exhaust is common with ejector exhaust.
- *5 Nozzle size 12 and 15 have exhaust port.
- *6 Refer to page 46 for the part number and maintenance of the high-noise reduction silencer case assembly.

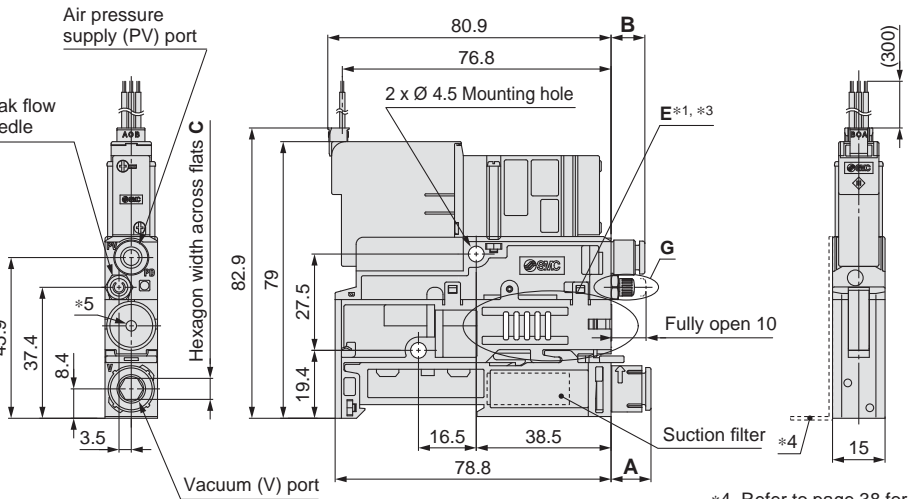

PV port type		B	
Metric size	06 Ø 6	9.7	
Inch size	07 Ø 1/4"	12.3	

V port type		A	C
Metric size	06 Ø 6	8.25	4
	08 Ø 8	11.4	6
Inch size	07 Ø 1/4"	9.7	4.76
	09 Ø 5/16"	11.4	6

*4 Refer to page 38 for dimensions with a mounting bracket.

ZK2P00^K□NL2A-□

Vacuum pump system, Single unit, With supply valve/release valve, Without pressure sensor/switch

For screwdriver operation type long lock nut

PE port female thread specification

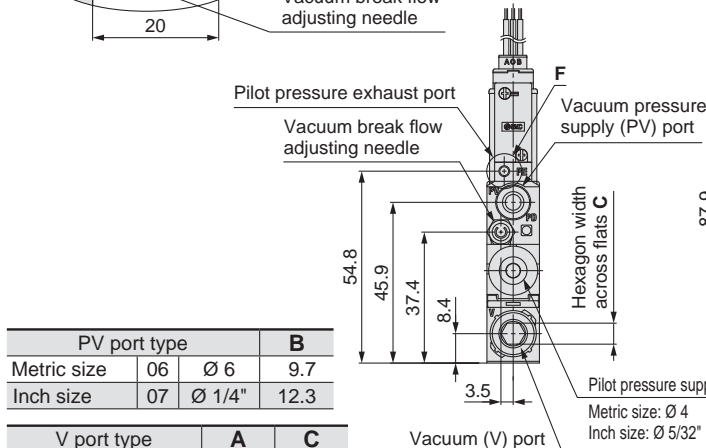
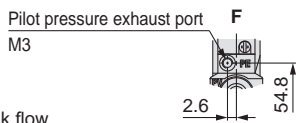
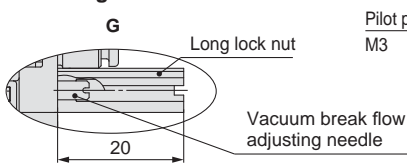

PV port type		B	
Metric size	06 Ø 6	9.7	
Inch size	07 Ø 1/4"	12.3	

V port type		A	C
Metric size	06 Ø 6	8.25	4
	08 Ø 8	11.4	6
Inch size	07 Ø 1/4"	9.7	4.76
	09 Ø 5/16"	11.4	6

*1 Refer to page 38 for dimensions with a mounting bracket.

Dimensions: Single Unit

ZK2^A_B□J□NL2A-□

Ejector system, Single unit, With supply valve,
Without pressure sensor/switch

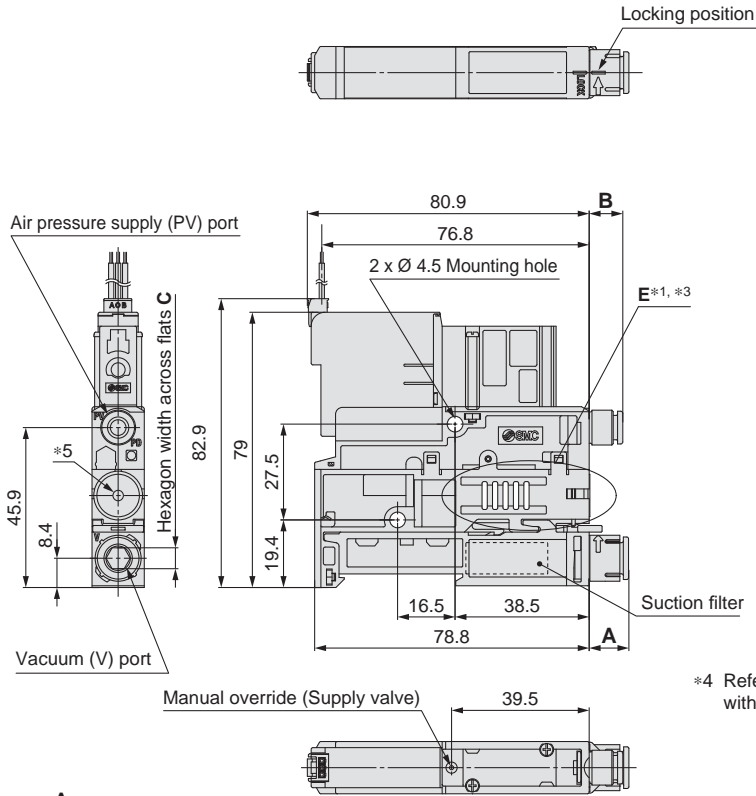

For high-noise reduction silencer exhaust

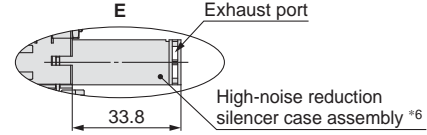

For port exhaust

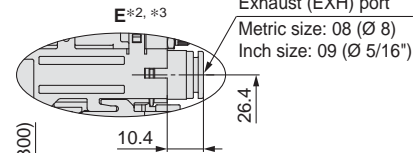

- *1 For silencer exhaust type, air is exhausted from the slit on both sides. (Do not cover both sides. Release at least one side.)
- *2 For port exhaust type, air is exhausted from the One-touch fitting.
- *3 Pilot pressure exhaust is common with ejector exhaust.
- *5 Nozzle size 12 and 15 have exhaust port.
- *6 Refer to page 46 for the part number and maintenance of the high-noise reduction silencer case assembly.

PV port type			B
Metric size	06	Ø 6	9.7
Inch size	07	Ø 1/4"	12.3

V port type		A	C
Metric size	06	Ø 6	8.25
	08	Ø 8	11.4
Inch size	07	Ø 1/4"	9.7
	09	Ø 5/16"	4.76
			6

*4 Refer to page 38 for dimensions with a mounting bracket.

ZK2^A_B□N0NNA-□

Ejector system, Single unit, Without valve,
Without pressure sensor/switch

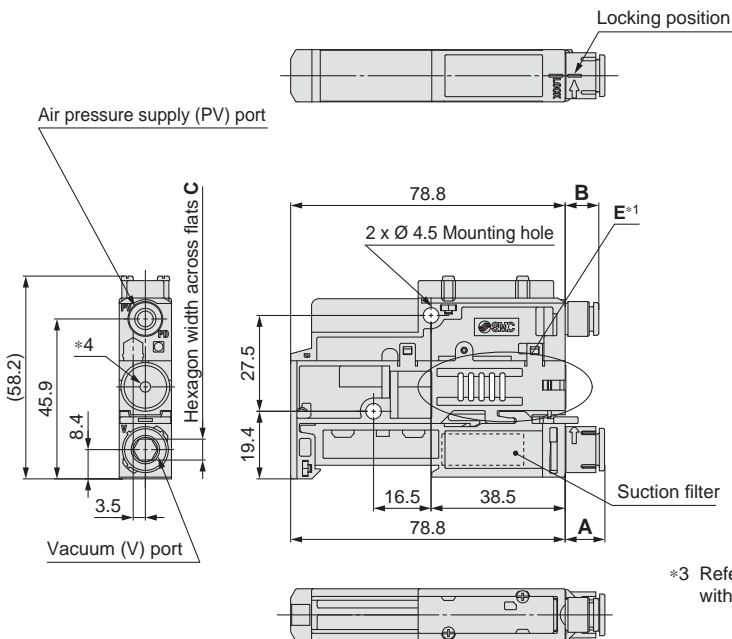

For high-noise reduction silencer exhaust

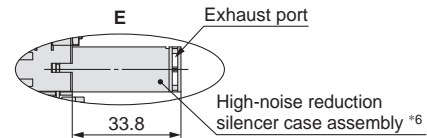

For port exhaust

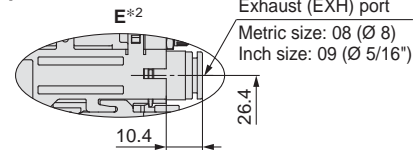

- *1 For silencer exhaust type, air is exhausted from the slit on both sides. (Do not cover both sides. Release at least one side.)
- *2 For port exhaust type, air is exhausted from the One-touch fitting.
- *4 Nozzle size 12 and 15 have exhaust port.
- *5 Refer to page 46 for the part number and maintenance of the high-noise reduction silencer case assembly.

PV port type			B
Metric size	06	Ø 6	9.7
Inch size	07	Ø 1/4"	12.3

V port type		A	C
Metric size	06	Ø 6	8.25
	08	Ø 8	11.4
Inch size	07	Ø 1/4"	9.7
	09	Ø 5/16"	4.76
			6

*3 Refer to page 38 for dimensions with a mounting bracket.

ZK2□A Series

Dimensions: Single Unit

ZK2^A_B□_G□_K□_R□_P□_TLA-□

Ejector system, Single unit,
With supply valve/release valve,
With pressure sensor

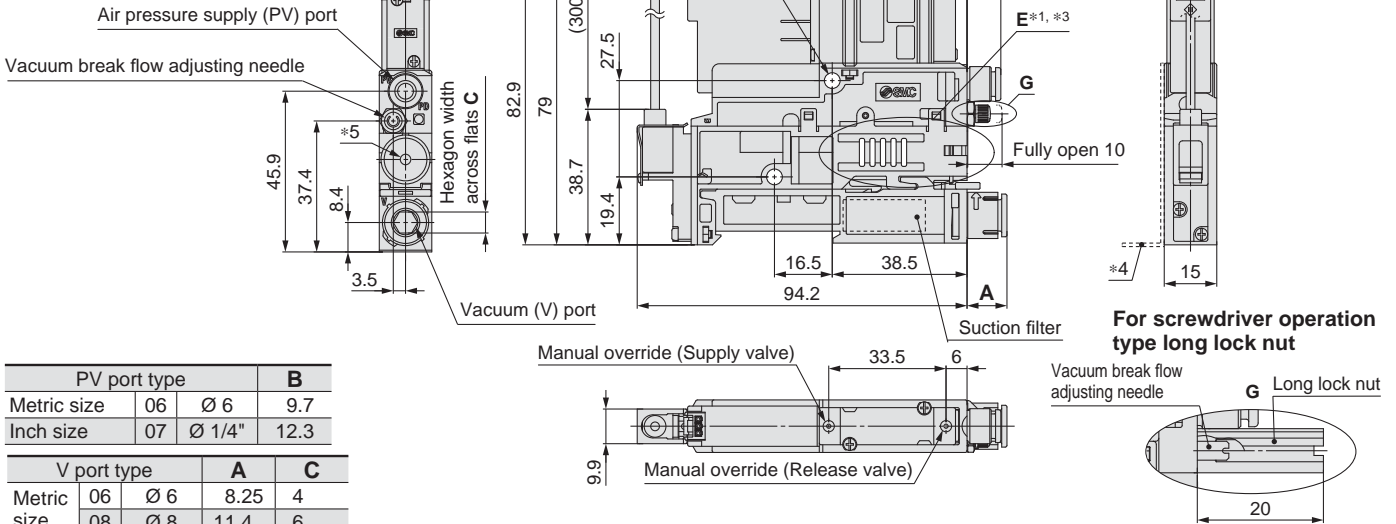

- *1 For silencer exhaust type, air is exhausted from the slit on both sides. (Do not cover both sides. Release at least one side.)
- *2 For port exhaust type, air is exhausted from the One-touch fitting.
- *3 Pilot pressure exhaust is common with ejector exhaust.
- *4 Refer to page 38 for dimensions with a mounting bracket.
- *5 Nozzle size 12 and 15 have exhaust port.
- *6 Refer to page 4 6 for the part number and maintenance of the high-noise reduction silencer case assembly.

ZK2^A_B□_G□_K□_R□_LLA-□
A to J

Ejector system, Single unit,
With supply valve/release valve,
With pressure switch

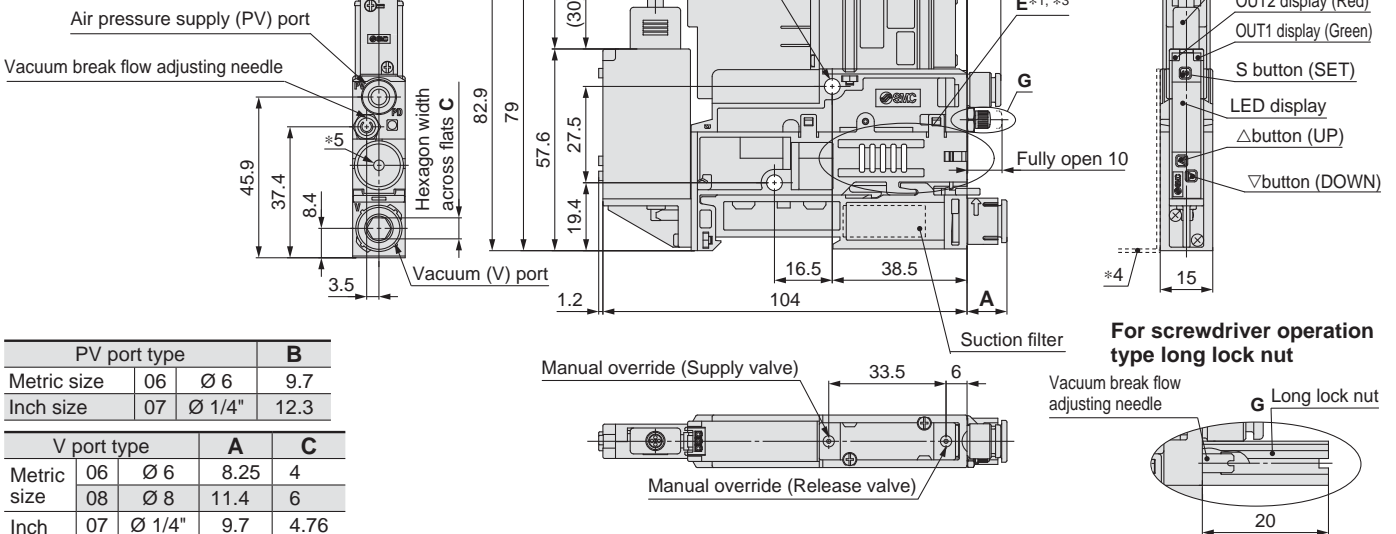

- *1 For silencer exhaust type, air is exhausted from the slit on both sides. (Do not cover both sides. Release at least one side.)
- *2 For port exhaust type, air is exhausted from the One-touch fitting.
- *3 Pilot pressure exhaust is common with ejector exhaust.
- *4 Refer to page 38 for dimensions with a mounting bracket.
- *5 Nozzle size 12 and 15 have exhaust port.
- *6 Refer to page 4 6 for the part number and maintenance of the high-noise reduction silencer case assembly.

Dimensions: Single Unit

ZK2^A□K□WA-□
G^B□□□_LK to S

Ejector system, Single unit, With supply valve/release valve, Pressure switch with energy saving function

For high-noise reduction silencer exhaust

For port exhaust

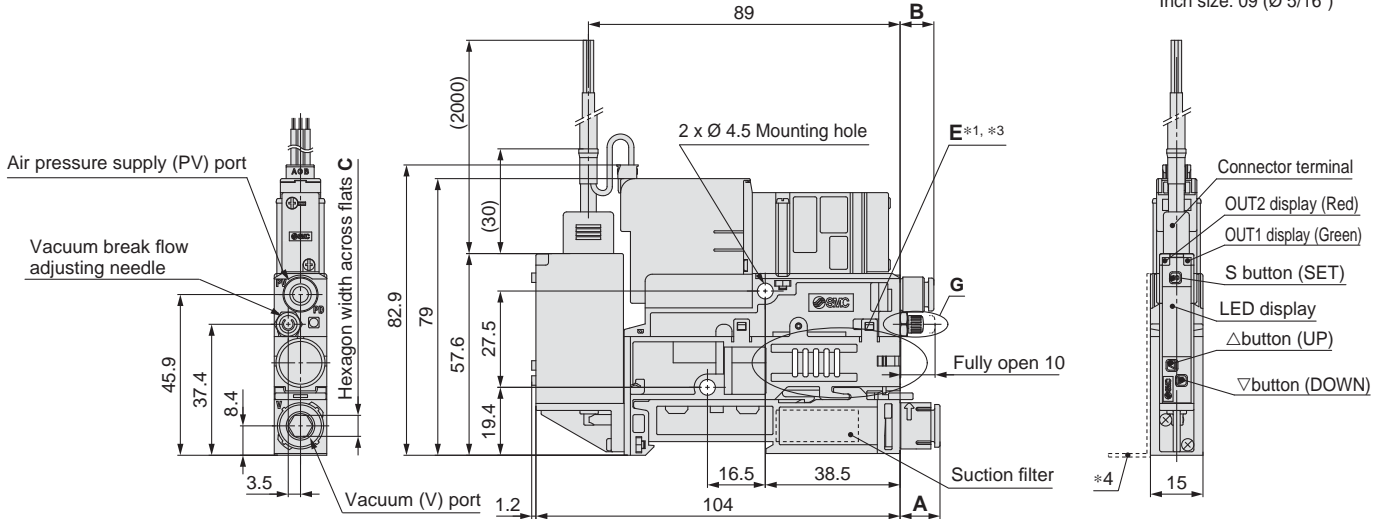

For screwdriver operation type long lock nut

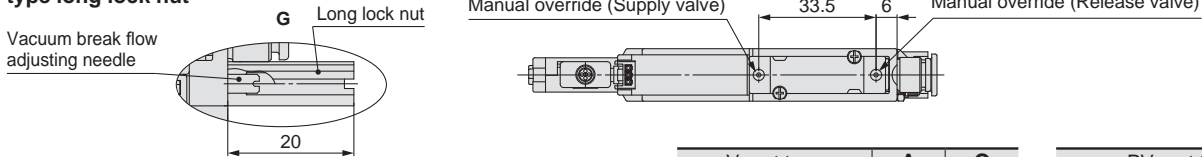

- *1 For silencer exhaust type, air is exhausted from the slit on both sides. (Do not cover both sides. Release at least one side.)
- *2 For port exhaust type, air is exhausted from the One-touch fitting.
- *3 Pilot pressure exhaust is common with ejector exhaust.
- *4 Refer to the following for dimensions with a mounting bracket.
- *5 Refer to page 4 6 for the part number and maintenance of the high-noise reduction silencer case assembly.

V port type		A	C
Metric size	06 Ø 6	8.25	4
Metric size	08 Ø 8	11.4	6
Inch size	07 Ø 1/4"	9.7	4.76
Inch size	09 Ø 5/16"	11.4	6

PV port type			B
Metric size	06 Ø 6	9.7	
Inch size	07 Ø 1/4"	12.3	

With bracket

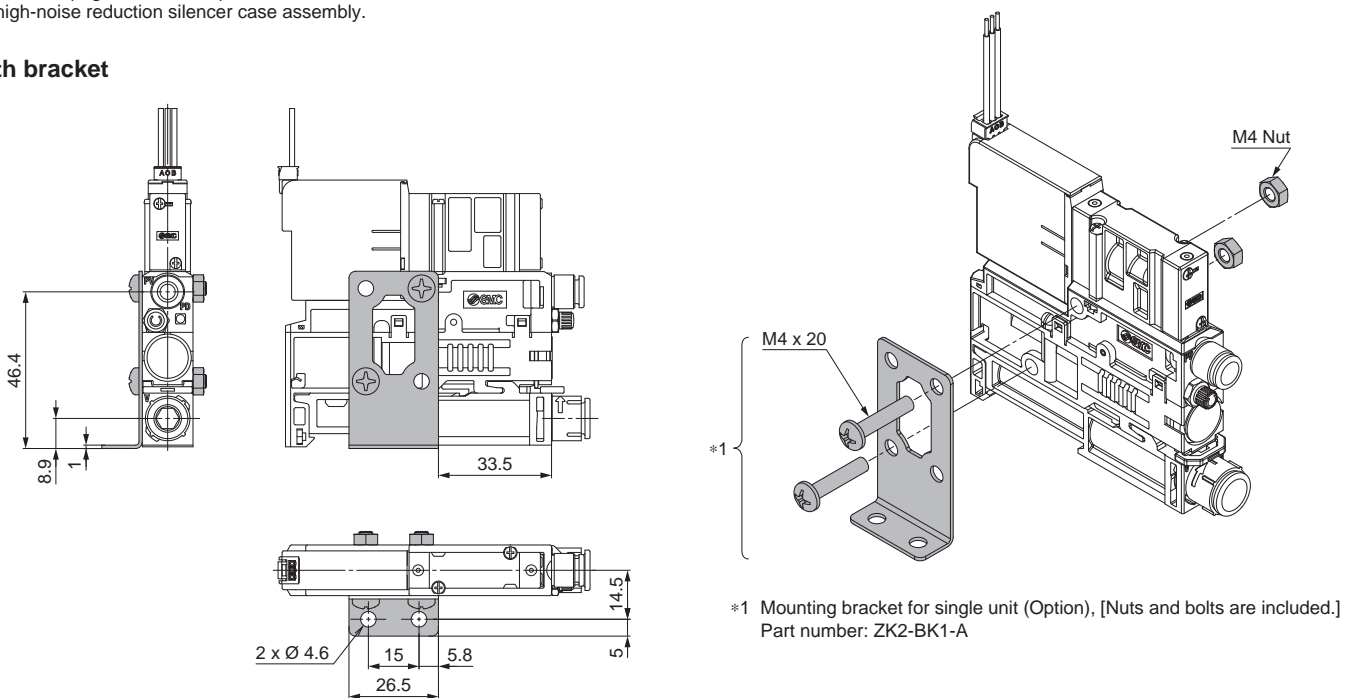

ZK2□A Series

Dimensions: Manifold Individual Wiring

ZZK2□A- P□L

Ejector system, Vacuum pump system, Individual wiring manifold,
With supply valve/release valve, Without pressure sensor/switch

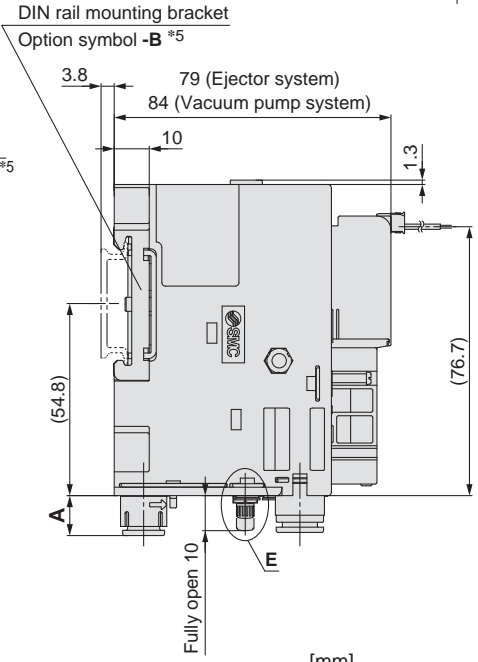
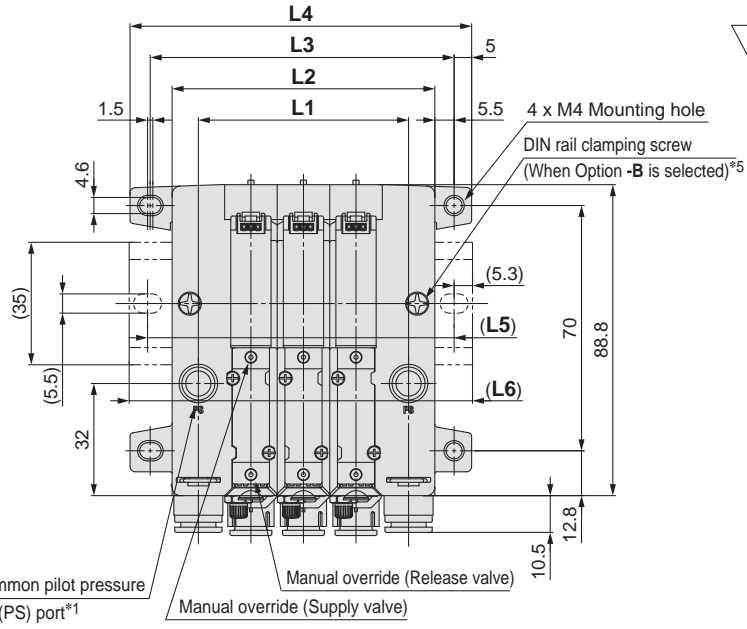
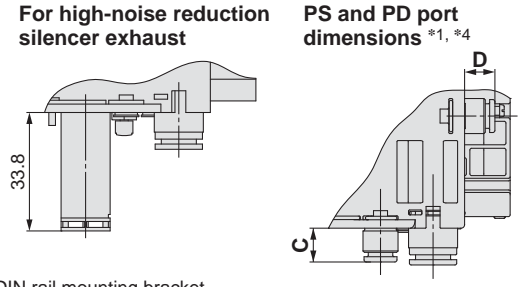
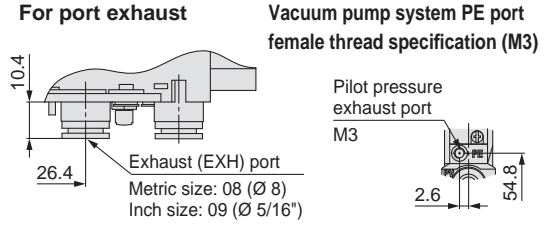
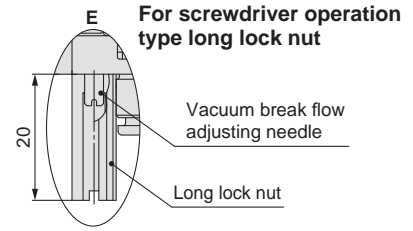
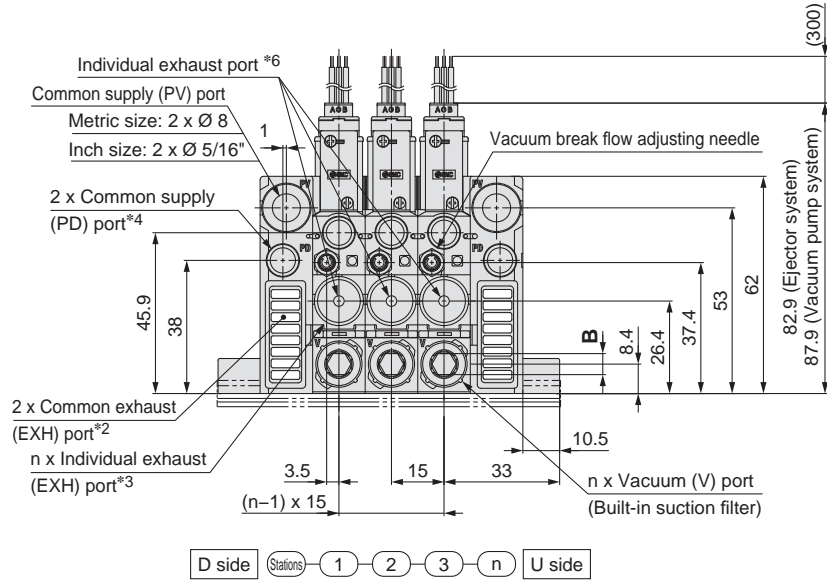

Port type	A	Hexagon width across flats B	C	D
Metric size	06 8.3	4	9.7	8.7
	08 11.4	6	—	—
Inch size	07 9.7	4.76	12.3	11.3
	09 11.4	6	—	—

Stations	1	2	3	4	5	6	7	8	9	10
L1	30	45	60	75	90	105	120	135	150	165
L2	45	60	75	90	105	120	135	150	165	180
L3	56.8	71.8	86.8	101.8	116.8	131.8	146.8	161.8	176.8	191.8
L4	67.5	82.5	97.5	112.5	127.5	142.5	157.5	172.5	187.5	202.5
L5	62.5	75	87.5	112.5	125	137.5	150	162.5	187.5	200
L6	73	85.5	98	123	135.5	148	160.5	173	198	210.5

*1 Common pilot pressure supply (PS) port is available for vacuum pump system or option L (Manifold individual supply specification). (mm: Ø 6 inch: Ø 1/4")
 *2 Vacuum pump system with individual exhaust port type does not have exhaust port.
 *3 When individual exhaust port type is selected (Body type: F)
 *4 Only when common PD port type option (Symbol: -D) is selected (mm: Ø 6 inch: Ø 1/4")
 *5 To fix the manifold to DIN rail, select an option for the manifold model number.
 *6 For complex exhaust type, air is also exhausted from the individual exhaust port of each station in addition to the common exhaust. (Ejector system)

Dimensions: Manifold D-sub Connector

ZZK2□A-_P□_AF

**Ejector system, Vacuum pump system, Common wiring manifold,
With supply valve/release valve, With pressure sensor**

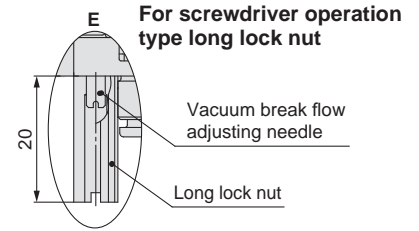
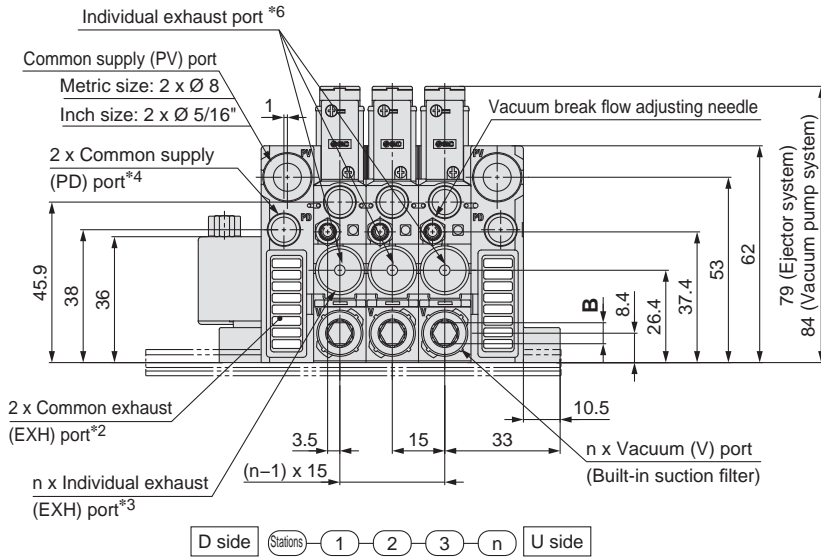

For port exhaust

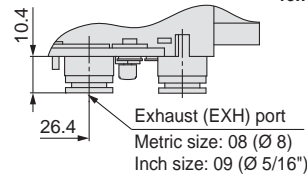

Vacuum pump system PE port female thread specification (M3)

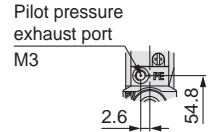

For high-noise reduction silencer exhaust

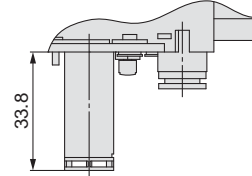

PS and PD port dimensions *1, *4

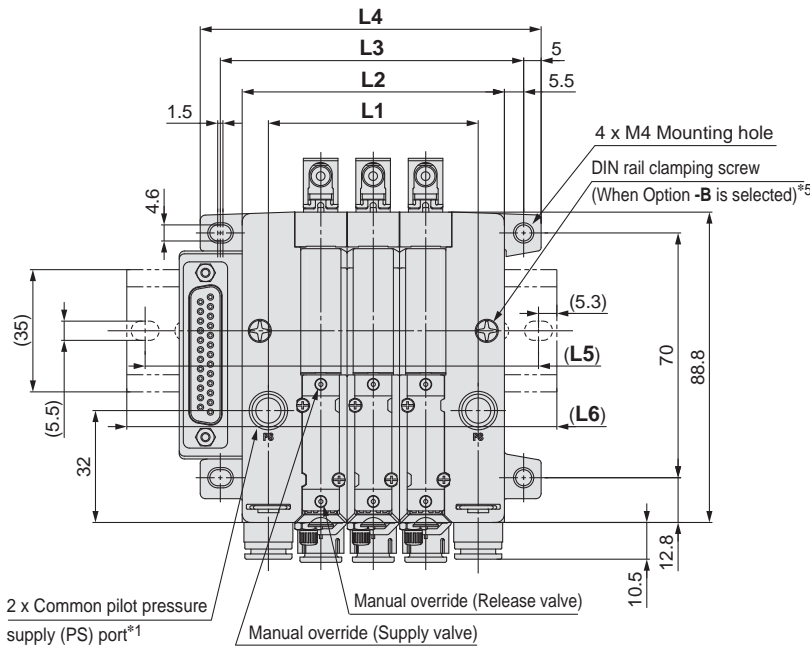
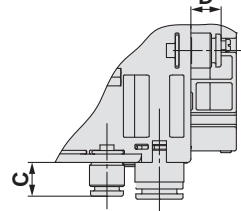

**DIN rail mounting bracket
Option symbol -B *5**

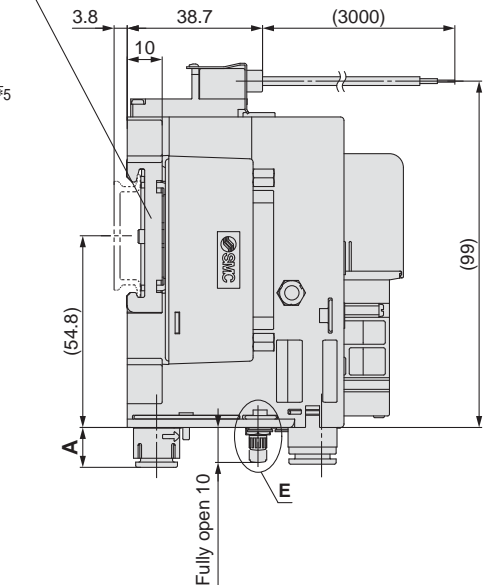

Port type	A	Hexagon width across flats B	C	D
Metric size	06	8.3	4	9.7
	08	11.4	6	—
Inch size	07	9.7	4.76	12.3
	09	11.4	6	—

Stations	1	2	3	4	5	6	7	8	9	10
L1	30	45	60	75	90	105	120	135	150	165
L2	45	60	75	90	105	120	135	150	165	180
L3	56.8	71.8	86.8	101.8	116.8	131.8	146.8	161.8	176.8	191.8
L4	73.5	88.5	103.5	118.5	133.5	148.5	163.5	178.5	193.5	208.5
L5	75	100	112.5	125	137.5	150	175	187.5	200	212.5
L6	85.5	110.5	123	135.5	148	160.5	185.5	198	210.5	223

*1 Common pilot pressure supply (PS) port is available for vacuum pump system or option L (Manifold individual supply specification). (mm: Ø 6 inch: Ø 1/4")
 *2 Vacuum pump system with individual exhaust port type does not have exhaust port.
 *3 When individual exhaust port type is selected (Body type: F)
 *4 Only when common PD port type option (Symbol: -D) is selected (mm: Ø 6 inch: Ø 1/4")
 *5 To fix the manifold to DIN rail, select an option for the manifold model number.
 *6 For complex exhaust type, air is also exhausted from the individual exhaust port of each station in addition to the common exhaust. (Ejector system)

ZK2□A Series

Dimensions: Manifold Flat Ribbon Cable

ZK2□A-_P□_A□_P

Ejector system, Common wiring manifold, With supply valve/release valve, With pressure switch

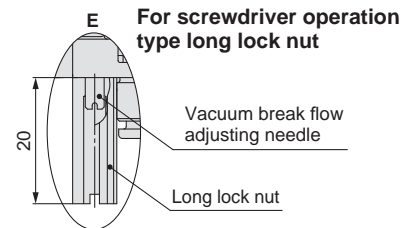
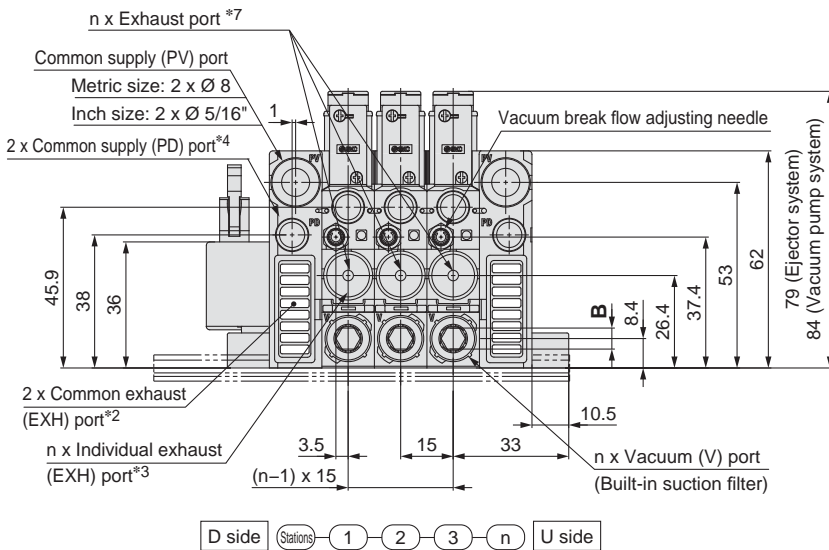

For port exhaust Vacuum pump system PE port female thread specification (M3)

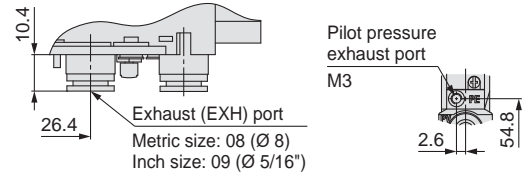

For high-noise reduction silencer exhaust PS and PD port dimensions *1, *4

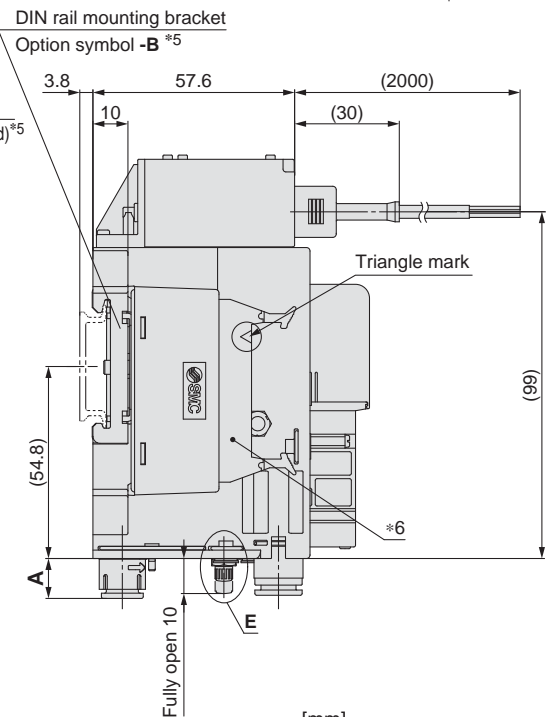
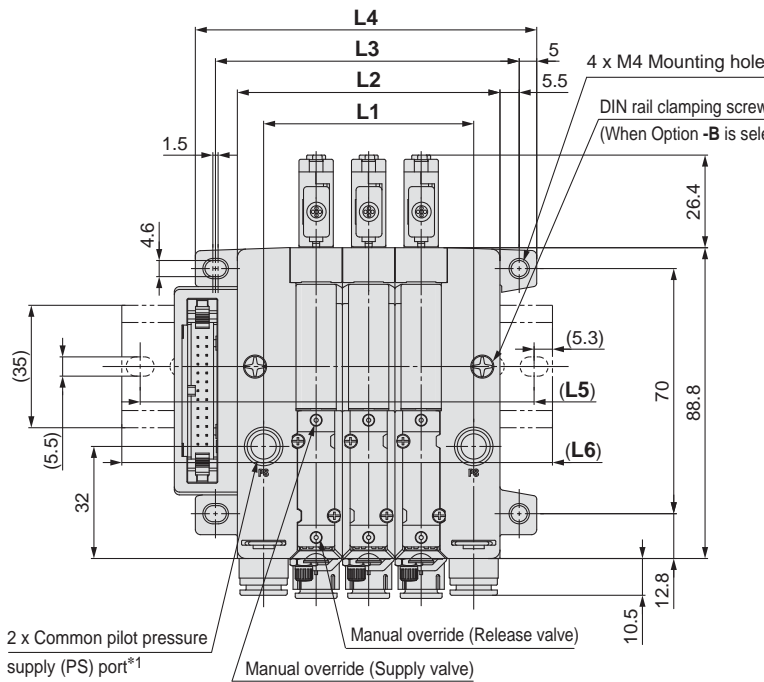
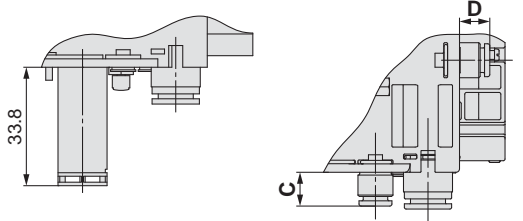

Port type	A	Hexagon width across flats B	C	D	
Metric size	06	8.3	4	9.7	8.7
	08	11.4	6	—	—
Inch size	07	9.7	4.76	12.3	11.3
	09	11.4	6	—	—

Stations	1	2	3	4	5	6	7	8	9	10
L1	30	45	60	75	90	105	120	135	150	165
L2	45	60	75	90	105	120	135	150	165	180
L3	56.8	71.8	86.8	101.8	116.8	131.8	146.8	161.8	176.8	191.8
L4	73.5	88.5	103.5	118.5	133.5	148.5	163.5	178.5	193.5	208.5
L5	75	100	112.5	125	137.5	150	175	187.5	200	212.5
L6	85.5	110.5	123	135.5	148	160.5	185.5	198	210.5	223

- *1 Common pilot pressure supply (PS) port is available for vacuum pump system or option L (Manifold individual supply specification). (mm: Ø 6 inch: Ø 1/4")
- *2 Vacuum pump system with individual exhaust port type does not have exhaust port.
- *3 When individual exhaust port type is selected (Body type: F)
- *4 Only when common PD port type option (Symbol: -D) is selected (mm: Ø 6 inch: Ø 1/4")
- *5 To fix the manifold to DIN rail, select an option for the manifold model number.
- *6 Applicable connector: Connector for flat ribbon cable (26P)(MIL-C-83503 compliant)
- *7 For complex exhaust type, air is also exhausted from the individual exhaust port of each station in addition to the common exhaust. (Ejector system)

Cable Assembly

D-sub Connector

015
AXT100-DS25-030
050

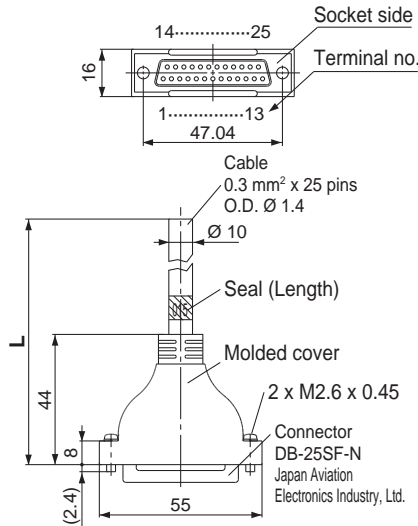

D-sub connector cable assembly Wire Colour by Terminal Number

Terminal number	Lead wire colour	Dot marking
1	Black	None
2	Brown	None
3	Red	None
4	Orange	None
5	Yellow	None
6	Pink	None
7	Blue	None
8	Purple	White
9	Grey	Black
10	White	Black
11	White	Red
12	Yellow	Red
13	Orange	Red
14	Yellow	Black
15	Pink	Black
16	Blue	White
17	Purple	None
18	Grey	None
19	Orange	Black
20	Red	White
21	Brown	White
22	Pink	Red
23	Grey	Red
24	Black	White
25	White	None

D-sub Connector Cable Assembly (Option)

Cable length (L)	Assembly part number	Note
1.5 m	AXT100-DS25-015	Cable 0.3 mm² x 25 cores
3 m	AXT100-DS25-030	
5 m	AXT100-DS25-050	

- * For other commercial connectors, use a 25-pin type with female connector conforming to MIL-C-24308.
- * Cannot be used for movable wiring

Electrical Characteristics

Item	Property
Conductor resistance Ω/km, 20 °C	65 or less
Voltage limit V, 1 min, AC	1000
Insulation resistance MΩ/km, 20 °C	5 or more

- * The minimum bending inner radius of D-sub connector cable is 20 mm.

Connector manufacturer's example

- Fujitsu Limited
- Japan Aviation Electronics Industry, Ltd.
- J.S.T. Mfg. Co., Ltd.
- HIROSE ELECTRIC CO., LTD.

Flat Ribbon Cable Connector

1
AXT100-FC26-2
3

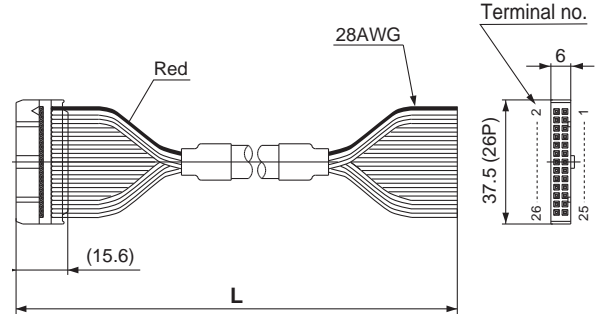

Flat Ribbon Cable Connector Assembly (Option)

Cable length (L)	Assembly part number
	26P
1.5 m	AXT100-FC26-1
3 m	AXT100-FC26-2
5 m	AXT100-FC26-3

- * For other commercial connectors, use a 26-pin type with strain relief conforming to MIL-C-83503.
- * Cannot be used for movable wiring

Connector manufacturer's example

- HIROSE ELECTRIC CO., LTD.
- 3M Japan Limited
- Fujitsu Limited
- Japan Aviation Electronics Industry, Ltd.
- J.S.T. Mfg. Co., Ltd.
- Oki Electric Cable Co., Ltd.



ZK2□A Series

Specific Product Precautions 1

Be sure to read this before handling the products. Refer to the back cover for safety instructions. For vacuum equipment precautions, refer to the “Handling Precautions for SMC Products” and the “Operation Manual” on the SMC website: <https://www.smc.eu>

Supply Valve / Release Valve

Warning

1. Manual override operation

- Manual override is non-locking push type. Push the manual override with a screwdriver of a diameter smaller than indicated in the diagram until it reaches the end.

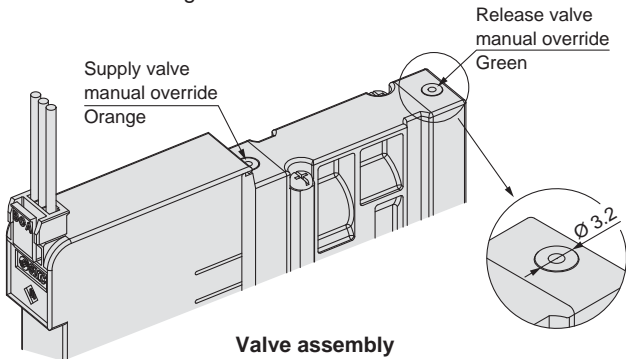

- Confirm that the product operates safely before the manual override is operated.
- When the valve type R is selected, the supply valve can hold the position and will not switch off even if the supply valve manual override operation is finished unless the release valve manual override is pressed.

2. Self-holding function of supply valve (Valve type R)

When the supply valve is energised (20 ms or more), the supply valve keep ON position even after energisation is stopped. When release valve is energised, the supply valve is turned off in conjunction with the operation of the release valve.

- Main valve in the valve assembly is made of elastic seal. Self-holding is performed by friction resistance of the seal. Do not apply impact resistance in the direction of the main valve shaft during the installation to moving parts. When impact is applied, use valve type K. (For vibration and impact, refer to the General Specifications on page 18.)
- In a vacuum pump system, the workpiece may not be released when the vacuum break flow adjusting needle is closed during the use. In addition, the OFF operation of the supply valve may become unstable. Open the vacuum break flow adjusting needle during use. If the vacuum break flow adjusting needle is expected to close during use due to a light workpiece, please select PD port type (single unit: manifold option [D] (for manifold: option [P])). Release the PD port to the atmosphere and open the vacuum break flow adjusting needle.
- Valve type R cannot use a pressure switch for vacuum with energy saving function. Use valve type K.

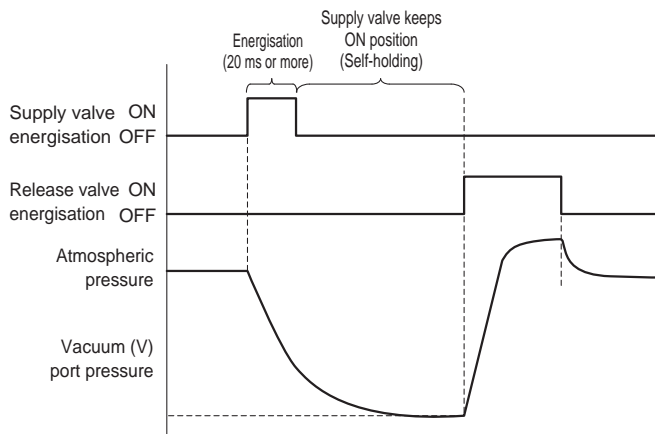

3. Default setting

When the valve assembly is delivered, the supply valve is on the OFF position, but it may be on the ON position due to the vibration or impact during transportation or device installation. Turn to the OFF position manually or by energising before use.

4. LED indication

Red LED turns on when supply valve is energised. Green LED turns on when release valve is energised.

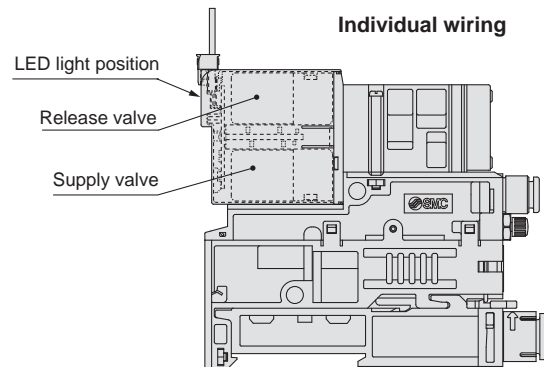
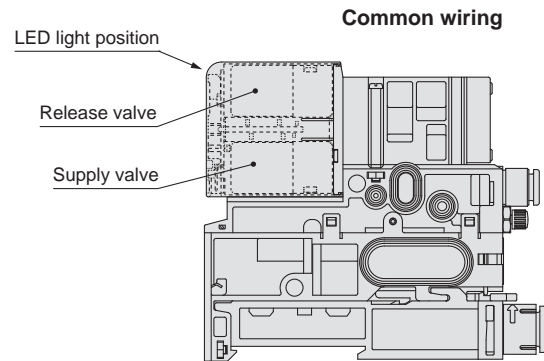

5. Continuous duty

If a supply valve is energised continuously for a long time, the rise in temperature due to heat-up of the coil may cause a decline in solenoid valve performance, reduce service life, or have adverse effects on peripheral equipment. When the energising time per day is longer than non-energising time, use the self-holding function of valve type R. (Energised time should be 20 ms or longer, and be as short as possible.)



ZK2□A Series

Specific Product Precautions 2

Be sure to read this before handling the products. Refer to the back cover for safety instructions. For vacuum equipment precautions, refer to the "Handling Precautions for SMC Products" and the "Operation Manual" on the SMC website: <https://www.smc.eu>

Surge Voltage Intrusion

⚠ Caution

The surge voltage created when the power supply is cut off could apply to the de-energised load equipment through the output circuit. In cases where the energised load equipment has a larger capacity (power consumption) and is connected to the same power supply as the product, the surge voltage could malfunction and/or damage the internal circuit element of the product and the internal device of the output equipment. To avoid this situation, place a diode which can suppress the surge voltage between the COM lines of the load equipment and output equipment.

Wiring

⚠ Caution

1. Individual wiring

- To install the connector, hold the cover and insert the connector straight pushing the connector lever with your finger. Ensure that the connector lever clip is properly inserted onto mating part.
- To remove the connector, hold the cover and pull out the connector straight pushing the connector lever clip.

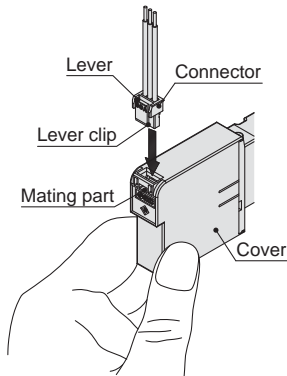

* Do not pull the lead wire with a force of 25 N or more, as this may damage the connector or cover.

2. Common wiring

- Align the socket connector of the cable and the plug connector of the manifold. Insert the socket connector of the cable into the plug connector of the manifold vertically. If the connector is pushed forcibly, the pin will bend and the connector cannot be joined.

Example) D-sub connector

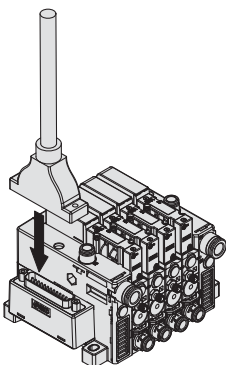

Replacement Procedure

⚠ Caution

1. Replacement Procedure for Filter Element

- 1) To pull out the vacuum port adapter, rotate the adapter by about 90 degrees in direction A and pull in direction B. The adapter can be removed with the suction filter from the filter case.
- 2) Remove the suction filter from the vacuum port adapter and replace it with a new suction filter.

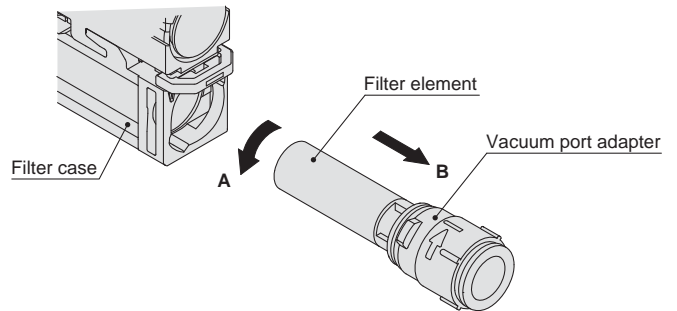

- 3) When installing the filter, insert the filter to the end so that there is no gap*1 or bending*2 between the filter and the vacuum port adapter. The gap or bending will cause the element to deform inside the case.

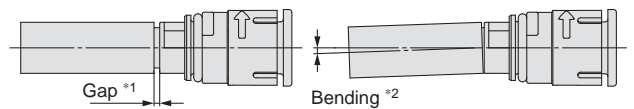

- 4) Put the filter back into the filter case following this procedure in reverse.

- To mount the vacuum port adapter into the filter case, turn the adapter so that the mating mark of the adapter and the case are aligned. (Rotation stops there.)

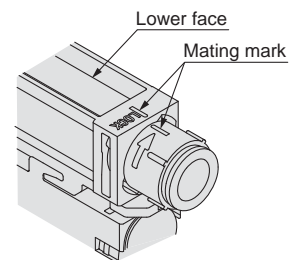

- If it is difficult to remove the vacuum port adapter, you can remove the adapter with a hexagon wrench using the hexagonal hole in V port. The table shows the port size and the width across flats.

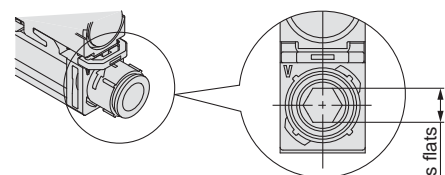

V port size	Width across flats
∅ 6	4
∅ 8, ∅ 5/16"	6
∅ 1/4"	4.76



ZK2□A Series

Specific Product Precautions 3

Be sure to read this before handling the products. Refer to the back cover for safety instructions. For vacuum equipment precautions, refer to the "Handling Precautions for SMC Products" and the "Operation Manual" on the SMC website: <https://www.smc.eu>

Replacement Procedure

Caution

2. Replacement Procedure for Sound Absorbing Material (for Silencer Exhaust)

- 1) Remove the filter case following ⑤ the procedure of filter case maintenance (page 47).
- 2) Flip the ejector, push the release lever again with a finger or precision screwdriver until the release lever stops.

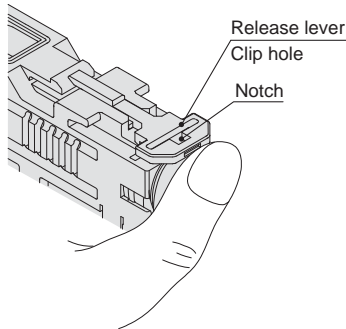

- 3) To remove the clip that holds the port plug, insert a precision screwdriver from the release lever notch. Move the screwdriver in direction ① to pull out the clip in direction ②.

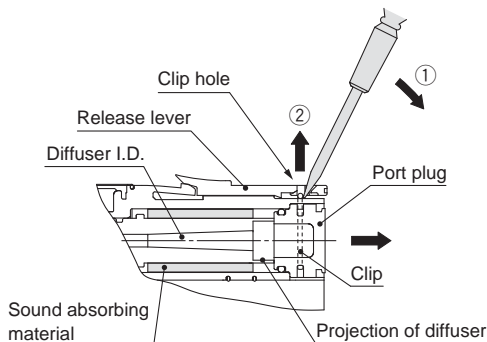

- 4) Remove the port plug.
- 5) Remove the sound absorbing material from the slit (hole) at the side of the body by using a precision screwdriver.
- 6) Insert the new sound absorbing material. Be careful not to scratch the material with the projection of the diffuser assembly.

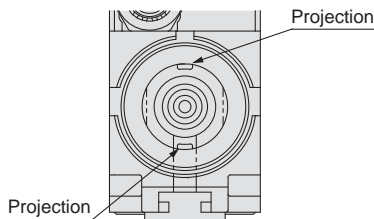

(Procedure to put parts back together)

- 7) Insert the port plug and insert the clip into the groove using the lever hole. (Push completely to the end.)

* Do not pull or bend the two projections at the end surface of the diffuser. These are spacers to prevent the displacement of the diffuser and they may break if force is applied.

- 8) Return the release lever in direction of ③ until it stops.

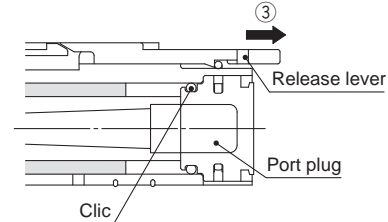

3. Replacement Procedure for High-noise Reduction Silencer Case Assembly

Refer to the replacement procedure of the sound absorbing material (silencer exhaust) to replace the assembly.

* When a high-noise reduction silencer case assembly is attached to body type "A" (silencer exhaust), the silencing effect cannot be acquired.

When only replacing the sound absorbing material (for high-noise reduction silencer exhaust)

- 1) Use the notch to remove the cap.
- 2) Use a precision screwdriver to remove the sound absorbing material.
- 3) Insert the new sound absorbing material, and return the cap.

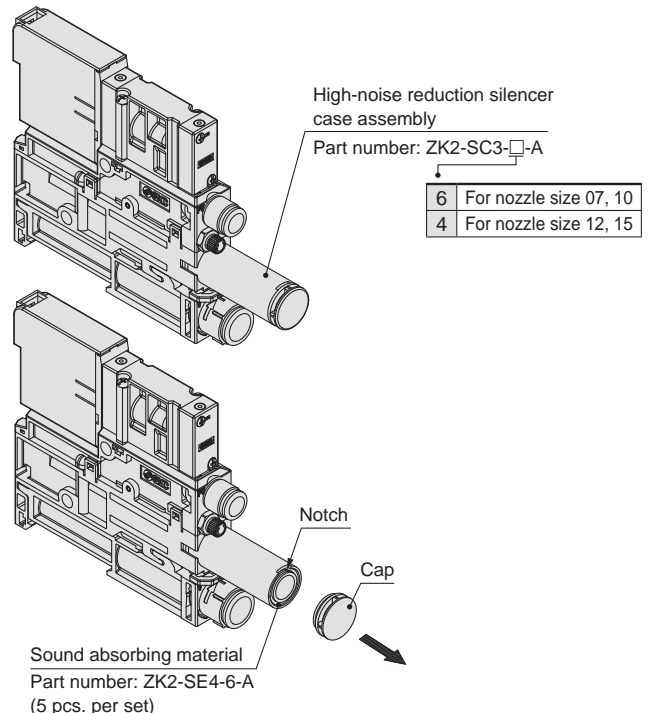

4. Replacement Procedure for Manifold Sound Absorbing Material

Replacement Procedure

- 1) Insert a precision screwdriver to notch A of the end plate and remove a clip L ①.
- 2) Insert a precision screwdriver to notch B and remove the silencer cover ②.
- 3) Pull out the sound absorbing material from the silencer cover ③.
- 4) Mounting of a new sound absorbing material should be performed by following the removal procedure in reverse.



ZK2□A Series

Specific Product Precautions 4

Be sure to read this before handling the products. Refer to the back cover for safety instructions. For vacuum equipment precautions, refer to the “Handling Precautions for SMC Products” and the “Operation Manual” on the SMC website: <https://www.smc.eu>

Replacement Procedure

⚠ Caution

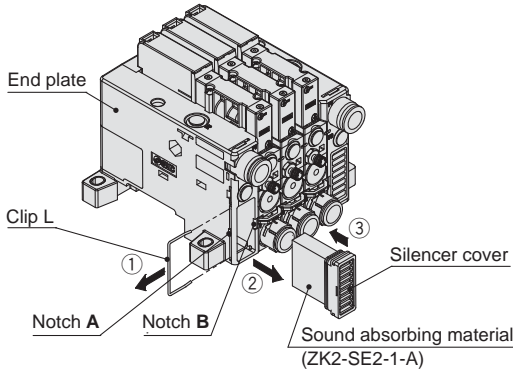

- Ejector system manifold common exhaust type has a sound absorbing material in the end plate. If the sound absorbing material is clogged, ejector performance is deteriorated, leading to suction failure or response delay. Regular replacement of the sound absorbing material is recommended.

5. Filter case maintenance

- 1) When the filter case is dirty, it can be removed and cleaned. To remove the filter case, insert a precision screwdriver into the groove of the release lever and push in direction (a), and slide the filter case in direction (b).

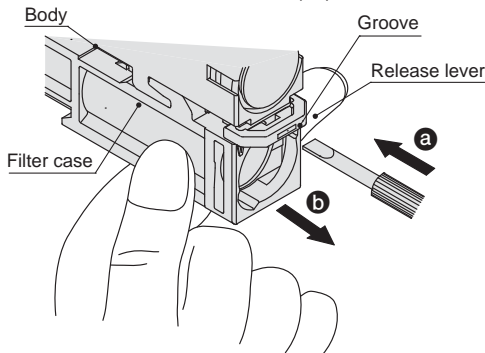

* Surface A of the filter case is the sealing surface when vacuum is generated. Handle with care so that the surface is not scratched or damaged.

* Filter case is made of polycarbonate. Avoid chemicals such as thinner, carbon tetrachloride, chloroform, acetic ester, aniline, cyclohexane, trichloroethylene, sulfuric acid, lactic acid, water base cutting fluid (alkaline).

* Do not expose the filter case to direct sunlight for a long period of time.

(Procedure to put parts back together)

- 2) Make sure that the body gasket that matches the product specifications is installed correctly onto the ejector. If they are out of the place, vacuum leakage may occur.

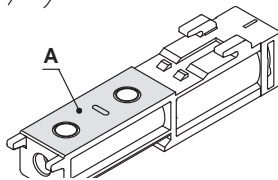

Replacement Procedure

⚠ Caution

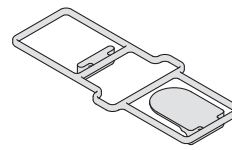
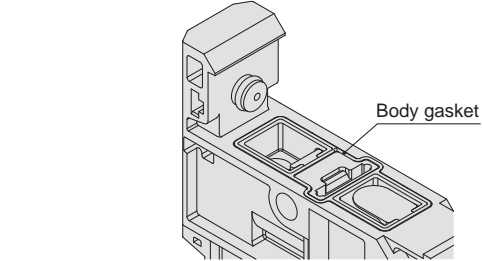

One check valve type
(All specifications other than switch with energy saving function and exhaust interference prevention valve)

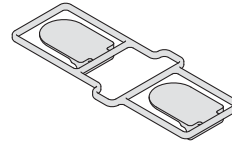

Two check valve type
(Switch with energy saving function and exhaust interference prevention valve)

- 3) Push the filter case in direction (c). Be careful the filter case hook (A) and hook (B) do not touch the body of the ejector.
- 4) Slide the filter case in direction (d) while pushing the filter case gently in contact with the ejector. Make sure that the clip (C) is locked and there is no gap in part (D).

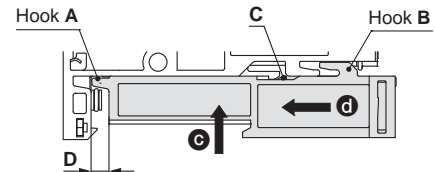

* If excess force is applied to the filter case, hook A and B may break. Handle with care.

Ejector Exhaust / Exhaust Noise

⚠ Caution

■ Ejector Exhaust

- The exhaust resistance should be as small as possible to obtain the full ejector performance. There should be no shield around the exhaust slit for silencer exhaust type. When the product is installed, one of the exhaust slits should be open to atmosphere.

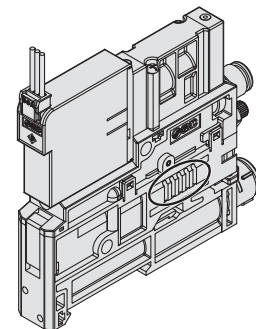



ZK2□A Series

Specific Product Precautions 5

Be sure to read this before handling the products. Refer to the back cover for safety instructions. For vacuum equipment precautions, refer to the "Handling Precautions for SMC Products" and the "Operation Manual" on the SMC website: <https://www.smc.eu>

Ejector Exhaust / Exhaust Noise

⚠ Caution

For the port exhaust specification, back pressure may increase depending on the size and length of the piping connected to the exhaust (EXH) port. Ensure that the back pressure does not exceed 0.005 MPa (5 kPa). Do not operate the ejector or apply pressure to the exhaust port with the exhaust port closed. This increases the pressure in the product and can damage the vacuum ejector.

- If the sound absorbing material is clogged, it will cause a reduction in the ejector performance. Sometimes, if the operating environment contains a lot of particles or mist, the replacement of the filter element only is not enough to recover vacuum performance - as the sound absorbing material may be clogged. Replace the sound absorbing material. (Regular replacement of the filter element and the sound absorbing material is recommended.)

■ Exhaust Noise

- When vacuum ejector generates vacuum, noise can be heard from the exhaust port when the standard supply pressure is close to the pressure that generates peak vacuum pressure making vacuum pressure unstable. If the vacuum pressure range is adequate for adsorption, there should not be a problem. If the noise causes a problem or affects the setting of the pressure switch, change the supply pressure slightly to avoid the pressure range of the noise.

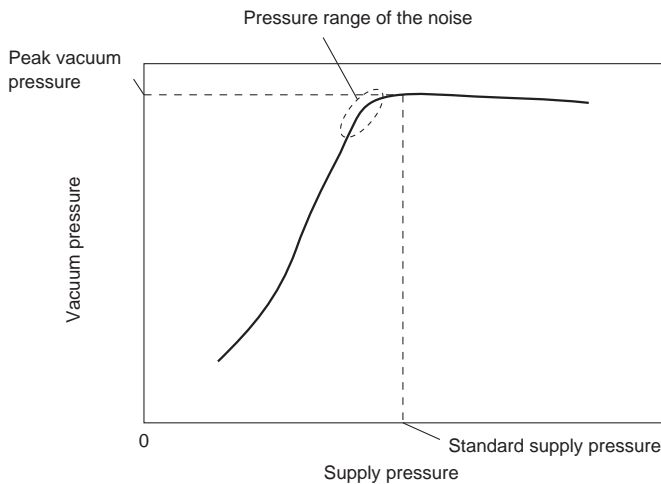

Operating Supply Pressure

⚠ Caution

- Use the product within the specified supply pressure range. Operation over the max. operating pressure can cause damage to the product. The parts around the vacuum port of this product are designed to be used with vacuum pressure. With the vacuum pump system, since air is not released to the atmosphere from a silencer, the applied air for vacuum release increases the internal pressure of the vacuum port. Select the vacuum pad which shape allows smooth exhaust of release air to the atmosphere and avoid logging.

Port Size

⚠ Caution

■ Single Unit

- The sizes of the each port are as follows. (Refer to the Application and Operating Pressure Range of Each Port on page 30.)

Port	Size			
	Ejector system		Vacuum pump system	
	Metric	Inch	Metric	Inch
PV	Ø 6	Ø 1/4"	Ø 6	Ø 1/4"
V	Ø 6, Ø 8	Ø 1/4", Ø 5/16"	Ø 6, Ø 8	Ø 1/4", Ø 5/16"
EXH (Port exhaust)	Ø 8	Ø 5/16"	—	—
PE	EXH Common		Port open to atmosphere *1	
PS	—	—	Ø 4	Ø 5/32"
PD *2	M3	—	M3	—

—: Not applicable

*1 Air is also exhausted from the pilot valve when the valve type is R. Piping for PE port is available as an option (M3). (Refer to pages 15 and 16.)

*2 A model with PD port is available as an option. (Refer to pages 9, 10, and 15.)

■ Manifold

- Manifold ports are common at the end plate. Port description and application are the same as the single unit. (Refer to the Application and Operating Pressure Range of Each Port on page 30.)
- Refer to page 18 for the number of stations that can operate simultaneously for each ejector size.
- If one side is not used for air supply, plug the unused port or change to the dedicated port plug assembly as shown below.

	Standard	Port plug assembly
Common PV port	Ø 8 One-touch fitting	VVQZ2000-CP
Common PS port	Ø 6 One-touch fitting	ZK2-MP1C6-A
Common PD port		

* There are 4 types of port combination due to the manifold port specification.

	Common EXH port	Common PS/PD ports	Application
ZK2□A-A□1□	Yes	PS = PD	Ejector common exhaust PV = PS = PD
ZK2□A-A□1□-D	Yes	PS ≠ PD	Ejector common exhaust PV = PS ≠ PD
ZK2□A-A□2□ ZK2□A-P2□	None	PS = PD	Ejector individual exhaust PV = PS = PD Vacuum pump system PV ≠ PS = PD
ZK2□A-A□2□-D ZK2□A-P2□-D	None	PS ≠ PD	Ejector individual exhaust PV = PS ≠ PD Vacuum pump system PV ≠ PS ≠ PD

- When PS = PD, the common PS/PD ports on the end plate are used, PS port is equipped with One-touch fitting and PD port is plugged at the time of shipment from the factory. Since the PS and PD are connected inside the end plate, common supply location can be changed by exchanging the One-touch fitting and the plug.
- When PS ≠ PD, PS and PD are not connected inside the end plate. (It is necessary to supply each port individually.)



ZK2□A Series

Specific Product Precautions 6

Be sure to read this before handling the products. Refer to the back cover for safety instructions. For vacuum equipment precautions, refer to the “Handling Precautions for SMC Products” and the “Operation Manual” on the SMC website: <https://www.smc.eu>

How to Mount a Single Unit

⚠ Caution

1. Single unit can be mounted to DIN rail or wall using the holes in the body (2 x Ø 4.5).

- When mounting the ejector to DIN rail, unlock the filter case assembly beforehand. (Refer to the maintenance procedure on page 47.)
- Hook the ejector onto the DIN rail from direction (①).
- Mount the ejector onto the DIN rail by pushing it down in direction (②).
- Push the filter case assembly in direction (③) until it is locked.

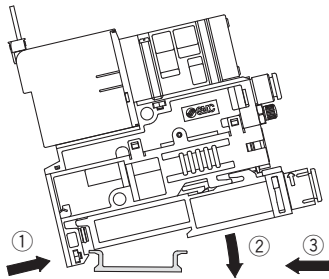

- To hold the ejector onto the DIN rail, hold it from both sides using the stopper brackets.

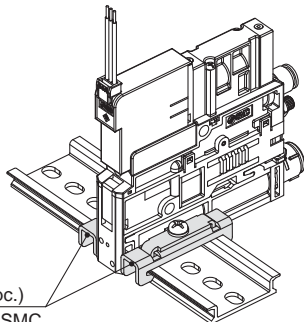

Stopper bracket (1 pc.)
Part number: TXE1-SMC

2. To mount a single unit onto the floor, use the optional bracket.

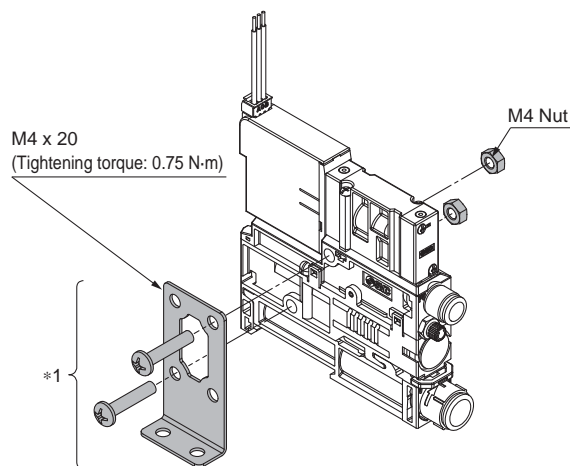

*1 Mounting bracket for single unit (Option), [Nuts and bolts are included.]
Part number: ZK2-BK1-A

How to Mount a Manifold

⚠ Caution

- Manifolds can be mounted onto the floor using M4 holes on the end plate.
- It is possible to mount the manifold onto the DIN rail by manifold option.
 - Hook the mounting bracket of the end plate to DIN rail from direction (①).
 - Mount the ejector onto the DIN rail by pushing it down in direction (②).
 - Use a 50 mm or longer Phillips screwdriver to tighten the mounting bracket (③). (Tightening torque: 0.9 ± 0.1 N-m)
 - Removal should be performed by following the mounting procedure in reverse.

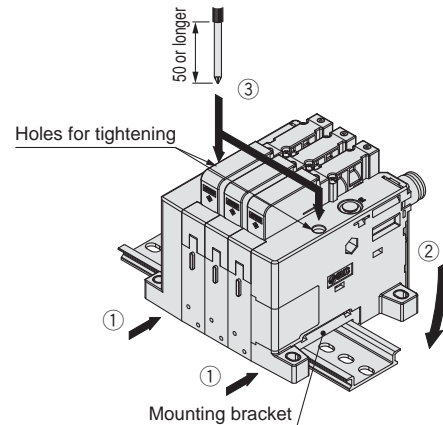

Vacuum Break Flow Adjusting Needle

⚠ Caution

1. The flow rate characteristics show the representative values of the product itself.

They may change depending on piping, circuit and pressure conditions, etc. The flow rate characteristics and the number of needle rotations vary due to the range of the specifications of the product.

2. The needle has a retaining mechanism, so it will not turn further when it reaches the rotation stop position.

Turning the needle too far may cause damage.

3. Do not tighten the handle with tools such as nippers.

This can result in breakage due to idle turning.

4. Do not over tighten the lock nut.

It is possible to tighten the standard lock nut (hexagon) manually. When tightening further with tools, tighten by approximately 15° to 30°. Over tightening may cause breakage.

5. When vacuum break flow adjusting needle screwdriver operation type (-K) is selected as option, make sure the lock nut is not loose to prevent the nut from coming off due to vibration.



ZK2□A Series

Specific Product Precautions 7

Be sure to read this before handling the products. Refer to the back cover for safety instructions. For vacuum equipment precautions, refer to the “Handling Precautions for SMC Products” and the “Operation Manual” on the SMC website: <https://www.smc.eu>

Interchangeability with Existing Product

⚠ Caution

When existing product is used, please be careful with the interchangeability between existing product in the table below and ZK2□A.

○ Single Unit

- New valve assembly of ZK2□A cannot be assembled with the existing products. (Pilot valve dimension and valve body dimension are different.)

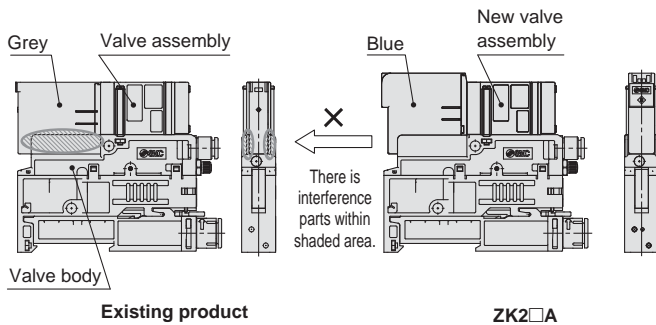

○ Manifold of 3 stations or more

- Single unit of ZK2□A for manifold cannot be assembled with the existing manifold. (Pilot valve dimension and end plate dimension are different.)

By replacing the manifold end plate assembly with the manifold end plate for ZK2□A, a single unit of ZK2□A for manifold can be assembled. Manifold end plate assembly number (Refer to page 33.)

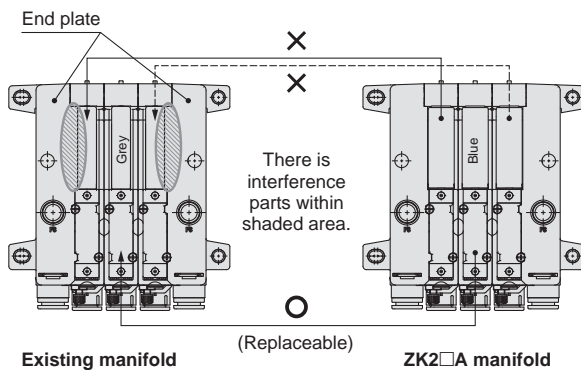

○ Manifold of 1 or 2 stations

- A single unit ZK2□A for manifold cannot be assembled with the existing manifold. (Pilot valve dimension and end plate dimension are different.)

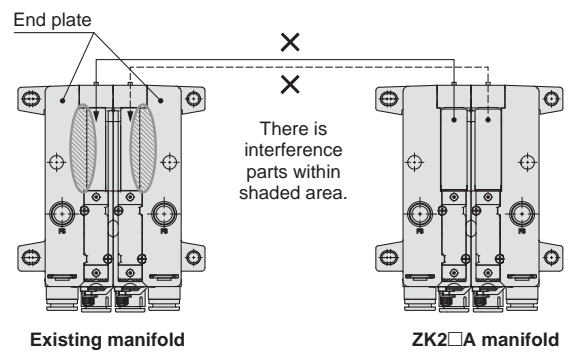

○ Replacement of the check valve

- The check valve and the gasket are separate parts for the conventional product, but ZK2□A is not interchangeable because it is integrated.

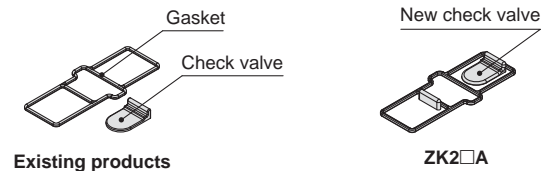



ZK2□A Series

Quality of Supply Air

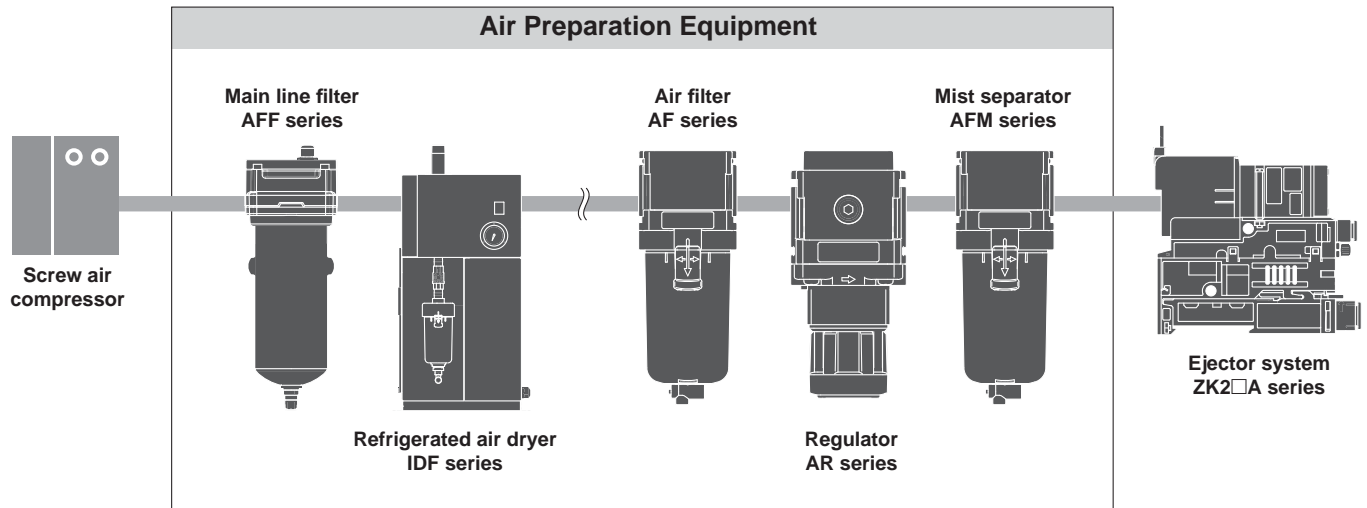

Quality of Supply Air

Supply air containing foreign matter, water, oil, condensate, etc., can cause malfunction of the supply valve and release valve. So, install air preparation equipment on the upstream side of the product (refer to the piping example below) and perform maintenance periodically to control the supply air properly.



Safety Instructions

These safety instructions are intended to prevent hazardous situations and/or equipment damage. These instructions indicate the level of potential hazard with the labels of “Caution,” “Warning” or “Danger.” They are all important notes for safety and must be followed in addition to International Standards (ISO/IEC)¹⁾, and other safety regulations.

-  **Caution:** **Caution** indicates a hazard with a low level of risk which, if not avoided, could result in minor or moderate injury.
-  **Warning:** **Warning** indicates a hazard with a medium level of risk which, if not avoided, could result in death or serious injury.
-  **Danger:** **Danger** indicates a hazard with a high level of risk which, if not avoided, will result in death or serious injury.

- 1) ISO 4414: Pneumatic fluid power – General rules relating to systems.
ISO 4413: Hydraulic fluid power – General rules relating to systems.
IEC 60204-1: Safety of machinery – Electrical equipment of machines.
(Part 1: General requirements)
ISO 10218-1: Manipulating industrial robots - Safety.
etc.

Warning

1. The compatibility of the product is the responsibility of the person who designs the equipment or decides its specifications.

Since the product specified here is used under various operating conditions, its compatibility with specific equipment must be decided by the person who designs the equipment or decides its specifications based on necessary analysis and test results. The expected performance and safety assurance of the equipment will be the responsibility of the person who has determined its compatibility with the product. This person should also continuously review all specifications of the product referring to its latest catalogue information, with a view to giving due consideration to any possibility of equipment failure when configuring the equipment.

2. Only personnel with appropriate training should operate machinery and equipment.

The product specified here may become unsafe if handled incorrectly. The assembly, operation and maintenance of machines or equipment including our products must be performed by an operator who is appropriately trained and experienced.

3. Do not service or attempt to remove product and machinery/equipment until safety is confirmed.

1. The inspection and maintenance of machinery/equipment should only be performed after measures to prevent falling or runaway of the driven objects have been confirmed.
2. When the product is to be removed, confirm that the safety measures as mentioned above are implemented and the power from any appropriate source is cut, and read and understand the specific product precautions of all relevant products carefully.
3. Before machinery/equipment is restarted, take measures to prevent unexpected operation and malfunction.

4. Contact SMC beforehand and take special consideration of safety measures if the product is to be used in any of the following conditions.

1. Conditions and environments outside of the given specifications, or use outdoors or in a place exposed to direct sunlight.
2. Installation on equipment in conjunction with atomic energy, railways, air navigation, space, shipping, vehicles, military, medical treatment, combustion and recreation, or equipment in contact with food and beverages, emergency stop circuits, clutch and brake circuits in press applications, safety equipment or other applications unsuitable for the standard specifications described in the product catalogue.
3. An application which could have negative effects on people, property, or animals requiring special safety analysis.
4. Use in an interlock circuit, which requires the provision of double interlock for possible failure by using a mechanical protective function, and periodical checks to confirm proper operation.

Caution

1. The product is provided for use in manufacturing industries.

The product herein described is basically provided for peaceful use in manufacturing industries.
If considering using the product in other industries, consult SMC beforehand and exchange specifications or a contract if necessary.
If anything is unclear, contact your nearest sales branch.

Limited warranty and Disclaimer/Compliance Requirements

The product used is subject to the following “Limited warranty and Disclaimer” and “Compliance Requirements”. Read and accept them before using the product.

Limited warranty and Disclaimer

1. The warranty period of the product is 1 year in service or 1.5 years after the product is delivered, whichever is first.²⁾ Also, the product may have specified durability, running distance or replacement parts. Please consult your nearest sales branch.
 2. For any failure or damage reported within the warranty period which is clearly our responsibility, a replacement product or necessary parts will be provided. This limited warranty applies only to our product independently, and not to any other damage incurred due to the failure of the product.
 3. Prior to using SMC products, please read and understand the warranty terms and disclaimers noted in the specified catalogue for the particular products.
- 2) Vacuum pads are excluded from this 1 year warranty.
A vacuum pad is a consumable part, so it is warranted for a year after it is delivered. Also, even within the warranty period, the wear of a product due to the use of the vacuum pad or failure due to the deterioration of rubber material are not covered by the limited warranty.

Compliance Requirements

1. The use of SMC products with production equipment for the manufacture of weapons of mass destruction (WMD) or any other weapon is strictly prohibited.
2. The exports of SMC products or technology from one country to another are governed by the relevant security laws and regulations of the countries involved in the transaction. Prior to the shipment of a SMC product to another country, assure that all local rules governing that export are known and followed.

Caution

SMC products are not intended for use as instruments for legal metrology.

Measurement instruments that SMC manufactures or sells have not been qualified by type approval tests relevant to the metrology (measurement) laws of each country. Therefore, SMC products cannot be used for business or certification ordained by the metrology (measurement) laws of each country.

Safety Instructions

Be sure to read “Handling Precautions for SMC Products” (M-E03-3) before using.

SMC Corporation (Europe)

Austria	+43 (0)2262622800	www.smc.at	office@smc.at
Belgium	+32 (0)33551464	www.smc.be	info@smc.be
Bulgaria	+359 (0)2807670	www.smc.bg	office@smc.bg
Croatia	+385 (0)13707288	www.smc.hr	office@smc.hr
Czech Republic	+420 541424611	www.smc.cz	office@smc.cz
Denmark	+45 70252900	www.smc.dk.com	smc@smc.dk.com
Estonia	+372 6510370	www.smc.pneumatics.ee	info@smc.ee
Finland	+358 207513513	www.smc.fi	smc.fi@smc.fi
France	+33 (0)164761000	www.smc-france.fr	info@smc-france.fr
Germany	+49 (0)61034020	www.smc.de	info@smc.de
Greece	+30 210 2717265	www.smchellas.gr	sales@smchellas.gr
Hungary	+36 23513000	www.smc.hu	office@smc.hu
Ireland	+353 (0)14039000	www.smcautomation.ie	sales@smcautomation.ie
Italy	+39 03990691	www.smcitalia.it	mailbox@smcitalia.it
Latvia	+371 67817700	www.smc.lv	info@smc.lv

Lithuania	+370 5 2308118	www.smclt.lt	info@smclt.lt
Netherlands	+31 (0)205318888	www.smc.nl	info@smc.nl
Norway	+47 67129020	www.smc-norge.no	post@smc-norge.no
Poland	+48 222119600	www.smc.pl	office@smc.pl
Portugal	+351 214724500	www.smc.eu	apoioclientept@smc.smces.es
Romania	+40 213205111	www.smcromania.ro	smcromania@smcromania.ro
Russia	+7 8123036600	www.smc.eu	sales@smcru.com
Slovakia	+421 (0)413213212	www.smc.sk	office@smc.sk
Slovenia	+386 (0)73885412	www.smc.si	office@smc.si
Spain	+34 945184100	www.smc.eu	post@smc.smces.es
Sweden	+46 (0)86031200	www.smc.nu	smc@smc.nu
Switzerland	+41 (0)523963131	www.smc.ch	helpcenter@smc.ch
Turkey	+90 212 489 0 440	www.smc.pnomatik.com.tr	info@smc.pnomatik.com.tr
UK	+44 (0)845 121 5122	www.smc.uk	sales@smc.uk