

Good Transient Response Low Voltage 500 mA LDO for Automotive Applications

NO.EC-241-200403

OUTLINE

The RP111x is a CMOS-based LDO regulator featuring 500 mA output current. The input voltage is as low as 1.4 V and the output voltage can be set from 0.7 V. Due to a built-in 0.46 Ω (at $V_{OUT} = 2.8$ V) on-resistor, RP111x can provide a low dropout voltage. RP111x also features an excellent line transient response, ripple rejection at 75 dB, and low noise. The output voltage accuracy is as high as $\pm 0.8\%$ and the temperature drift coefficient of output voltage is low at ± 30 ppm/ $^{\circ}\text{C}$. The accuracy of the output voltage of RP111x includes the temperature characteristics and the load transient response has been improved. The typ. and max value of under/overshoot for various output current are shown in the typical characteristics, therefore the accuracy of the output voltage estimation will be easy on the actual operating cases. In addition to a fold-back protection circuit built into conventional regulators, RP111x contains a thermal shutdown circuit and an inrush current limit circuit.

SOT-23-5, SOT-89-5, and HSOP-6J packages are available.

FEATURES

- Input Voltage Range (Maximum Rating)..... 1.4 V to 5.25 V (6.0 V)
- Operating Temperature -40°C to 105°C
- Supply Current..... Typ. 80 μA
- Standby Current Typ. 0.1 μA
- Dropout Voltage Typ. 0.23 V ($I_{OUT} = 500$ mA, $V_{SET} = 2.5$ V)
- Ripple Rejection Typ. 75 dB ($f = 1$ kHz)
Typ. 70 dB ($f = 10$ kHz)
- Output Voltage Accuracy $\pm 0.8\%$ ($V_{SET} \geq 1.8$ V)
- Output Voltage Temperature Coefficient..... Typ. ± 30 ppm/ $^{\circ}\text{C}$ ($V_{SET} \geq 1.8$ V)
- Feedback Voltage Accuracy..... 0.7 \pm 18 mV
- Feedback Voltage Temperature Coefficient..... Typ. ± 100 ppm/ $^{\circ}\text{C}$
- Line Regulation Typ. 0.02%/V
- Input Transient Response..... Typ. ± 1.5 mV ($V_{IN}: V_{SET} + 0.5$ V \leftrightarrow $V_{SET} + 1.5$ V ($t_r = t_f = 5.0$ μs),
 $V_{IN} \geq 1.4$ V, $I_{OUT} = 30$ mA)
- Packages..... SOT-23-5, SOT-89-5, HSOP-6J
- Output Voltage Range 0.7 V, 1.2 V, 1.5 V, 1.8 V, 2.5 V, 2.8 V, 2.85 V, 2.9 V, 3.0 V,
3.3 V, 3.4 V
Contact Ricoh sales representatives for other voltages.
RP111x001B/D: 0.7 V to 3.6 V (Adjustable with external resistor)
- Built-in Fold-back Protection Circuit Typ. 50 mA
- Thermal Shutdown Temperature 165°C
- Inrush Current Limit..... Typ. 400 mA (for 180 μs after start-up)
- Ceramic capacitors are recommended to be used with this IC
..... 1.0 μF or more (Internally Fixed Output Voltage)
- Output Noise 20 x V_{SET} μVrms (BW = 10 Hz to 100 kHz, $V_{SET} \geq 1.8$ V)

APPLICATIONS

- Power source for accessories such as car audios, car navigation systems, and ETC systems
- Power source for ECUs such as EV inverter and battery charge control unit

BLOCK DIAGRAMS

Internally Fixed Output Voltage (HSOP-6J)

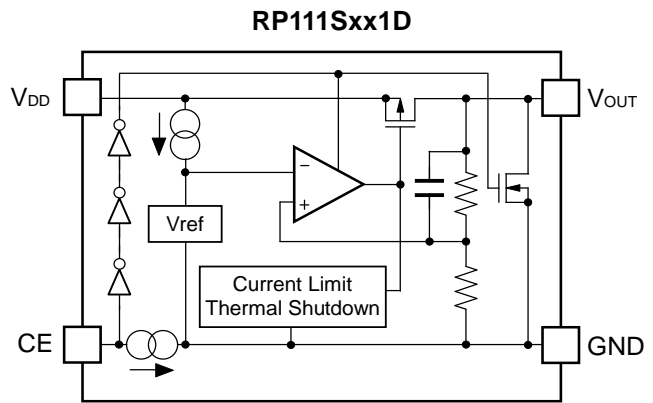
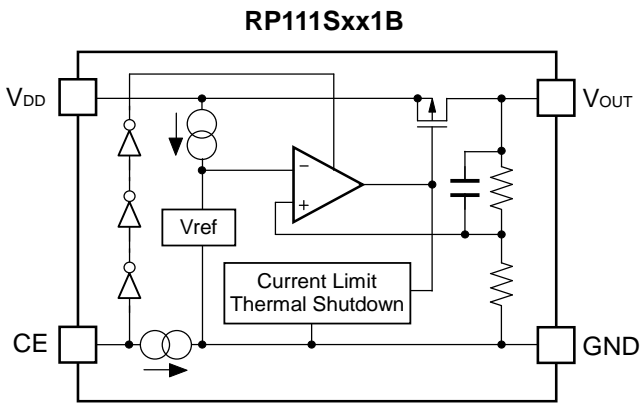

Internally Fixed Output Voltage (SOT-23-5/ SOT-89-5)

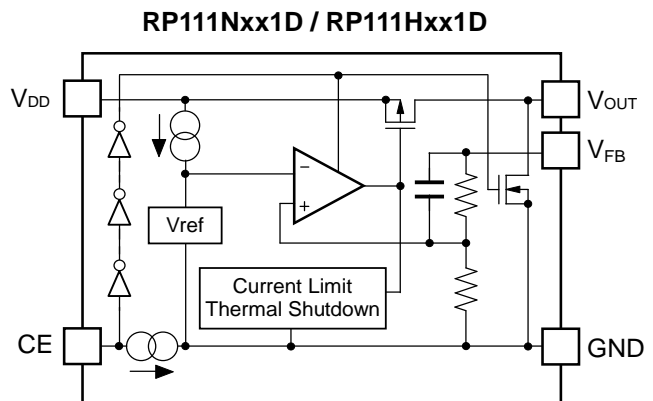
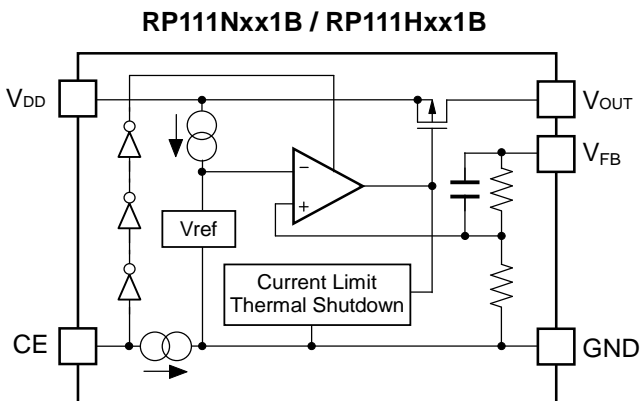

Externally Adjustable Output Voltage (HSOP-6J/ SOT-23-5/ SOT-89-5)

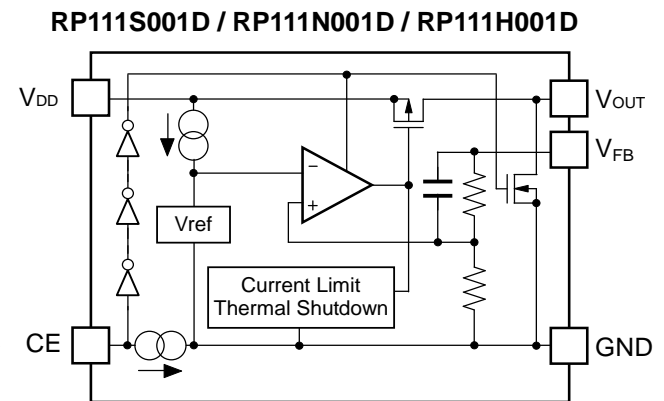
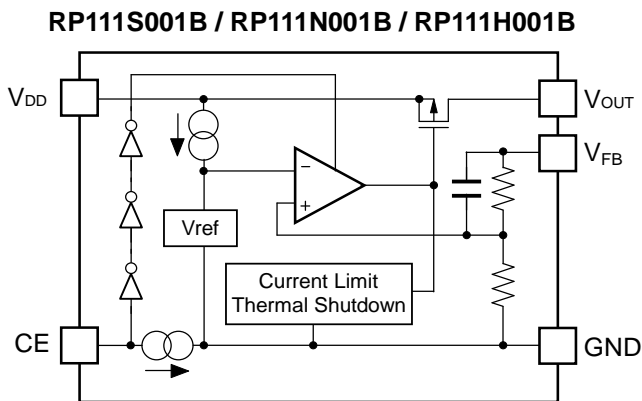

SELECTION GUIDE

The set output voltage, auto-discharge function^{*1}, and package type for the IC are user-selectable.

Product Name	Package	Quantity per Reel	Pb Free	Halogen Free
RP111Nxx1*-TR-#E	SOT-23-5	3,000 pcs	Yes	Yes
RP111N001*-TR-#E				
RP111Hxx1*-T1-#E	SOT-89-5	1,000 pcs	Yes	Yes
RP111H001*-T1-#E				
RP111Sxx1*-E2-#E	HSOP-6J	1,000 pcs	Yes	Yes
RP111S001*-E2-#E				

RP111x001B/D: Adjustable with external resistor

xx: Specify the set output voltage (V_{SET})

0.7 V (07), 1.2 V (12), 1.5 V (15), 1.8 V (18), 2.5 V (25), 2.8 V (28), 2.9 V (29), 3.0 V (30),
3.3 V (33), 3.4 V (34)

2.85 V: RP111x281*5

Contact Ricoh sales representatives for other voltages.

*: Specify the auto-discharge function at off state

- (B) Active-high, without auto discharge function at off state
- (D) Active-high, with auto discharge function at off state

#: Specify Automotive Class Code

	Operating Temperature Range	Guaranteed Specs Temperature Range	Screening
A	-40°C to 105°C	25°C	High Temperature
J	-40°C to 105°C	-40°C to 105°C	High and Low Temperature

^{*1} Auto-discharge function quickly lowers the output voltage to 0 V by releasing the electrical charge in the external capacitor when the chip enable signal is switched from the active mode to the standby mode.

PIN DESCRIPTIONS

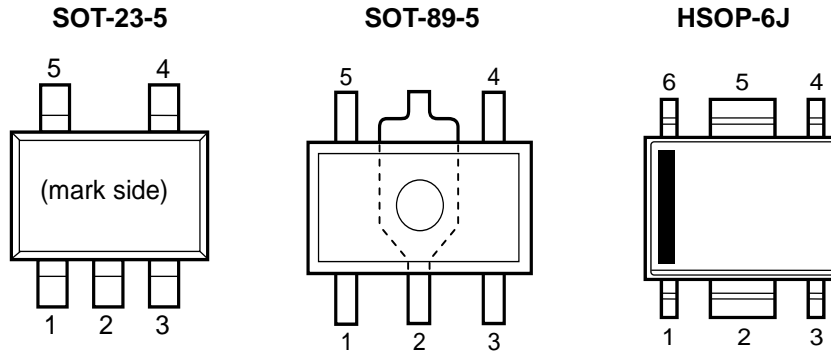

SOT-23-5

Pin No.	Symbol	Description
1	V _{DD}	Input Pin
2	GND	Ground Pin
3	CE	Chip Enable Pin (Active-high)
4	V _{FB}	Feed Back Pin
5	V _{OUT}	Output Pin

The V_{OUT} pin should be connected to the V_{FB} pin when using RP111x as an internal fixed output voltage type. In case of using this device as an external adjustable type, refer to *Adjustable Output Voltage Type Setting* for detailed information.

SOT-89-5

Pin No.	Symbol	Description
1	V _{FB}	Feed Back Pin
2	GND	Ground Pin
3	CE	Chip Enable Pin (Active-high)
4	V _{DD}	Input Pin
5	V _{OUT}	Output Pin

The V_{OUT} pin should be connected to the V_{FB} pin when using RP111x as an internal fixed output voltage type. In case of using this device as an external adjustable type, refer to *Adjustable Output Voltage Type Setting* for detailed information.

HSOP-6J

Pin No.	Symbol	Description
1	V _{OUT}	Output Pin
2	GND	Ground Pin
3	GND	Ground Pin (Internal fixed output voltage type: RP111Sxx1B/D)
	V _{FB}	Feed Back Pin (Adjustable output voltage type: RP111S001B/D)
4	CE	Chip Enable Pin
5	GND	Ground Pin
6	V _{DD}	Input Pin

In case of using this device as an external adjustable type, refer to *Adjustable Output Voltage Type Setting* for detailed information.

ABSOLUTE MAXIMUM RATINGS

Symbol	Item	Rating	Unit
V _{IN}	Input Voltage	-0.3 to 6.0	V
V _{CE}	Input Voltage (CE Pin)	-0.3 to 6.0	V
V _{OUT}	Output Voltage	-0.3 to V _{IN} + 0.3	V
I _{OUT}	Output Current	510	mA
P _D	Power Dissipation* ¹ (JEDEC STD. 51)	SOT-23-5	830
		SOT-89-5	3200
		HSOP-6J	3400
T _j	Junction Temperature	-40 to 150	°C
T _{stg}	Storage Temperature	-55 to 150	°C

*¹ Refer to *PACKAGE INFORMATION* for detailed information.

ABSOLUTE MAXIMUM RATINGS

Electronic and mechanical stress momentarily exceeded absolute maximum ratings may cause permanent damage and may degrade the lifetime and safety for both device and system using the device in the field. The functional operation at or over these absolute maximum ratings are not assured.

RECOMMENDED OPERATING CONDITIONS

Symbol	Item	Rating	Unit
V _{IN}	Input Voltage ^{*2}	1.4 to 5.25	V
T _a	Operating Temperature	-40 to 105	°C

*² In case of exceeding the maximum Input Voltage of 5.25 V, the device must be operated on condition that the Input Voltage is up to 5.5 V and the total operating time is within 500 hrs.

RECOMMENDED OPERATING CONDITIONS

All of electronic equipment should be designed that the mounted semiconductor devices operate within the recommended operating conditions. The semiconductor devices cannot operate normally over the recommended operating conditions, even if they are used over such conditions by momentary electronic noise or surge. And the semiconductor devices may receive serious damage when they continue to operate over the recommended operating conditions.

RP111x

NO.EC-241-200403

ELECTRICAL CHARACTERISTICS $V_{IN} = V_{SET} + 1.0 \text{ V}$ ($V_{SET} > 1.5 \text{ V}$), $V_{IN} = 2.5 \text{ V}$ ($V_{SET} \leq 1.5 \text{ V}$), $I_{OUT} = 1 \text{ mA}$, $C_{IN} = C_{OUT} = 1.0 \mu\text{F}$, unless otherwise noted.The specifications surrounded by are guaranteed by design engineering at $-40^\circ\text{C} \leq T_a \leq 105^\circ\text{C}$.**RP111xxx1D/B (-AE) (Fixed Output Voltage Type)**

(Ta = 25°C)

Symbol	Item	Conditions	Min.	Typ.	Max.	Unit
V _{OUT}	Output voltage	Ta = 25°C	V _{SET} ≥ 1.8 V	x 0.992	x 1.008	V
			V _{SET} < 1.8 V	-18	18	mV
		-40°C ≤ Ta ≤ 105°C	V _{SET} ≥ 1.8 V	x 0.985	x 1.015	V
			V _{SET} < 1.8 V	-55	50	mV
I _{OUT}	Output Current		500		mA	
ΔV _{OUT} /ΔI _{OUT}	Load regulation	1 mA ≤ I _{OUT} ≤ 500 mA		1	20	mV
V _{TRLD}	Load Transient Response	I _{OUT} : 1 mA ↔ 250 mA (tr = tf = 0.5 μs)	C _{OUT} = 1 μF	-75 +45		mV
			C _{OUT} = 2.2 μF	-55 +35		
		I _{OUT} : 1 mA ↔ 250 mA (tr = tf = 5 μs)	C _{OUT} = 1 μF	-20 +15		
V _{DIF}	Dropout Voltage	Refer to the <i>Dropout Voltage</i>				
I _{SS}	Supply Current	I _{OUT} = 0 mA		80	125	μA
I _{standby}	Standby Current	V _{CE} = 0 V		0.1	7.0	μA
ΔV _{OUT} /ΔV _{IN}	Line regulation	V _{SET} + 0.5 V ≤ V _{IN} ≤ 5.25 V, V _{IN} ≥ 1.4 V		0.02	0.10	%/V
I _{SC}	Short Current Limit	V _{OUT} = 0 V		50		mA
I _{PD}	CE Pull-down Current			0.3	0.6	μA
V _{CEH}	CE Input Voltage "H"		1.0			V
V _{CEL}	CE Input Voltage "L"				0.4	V
T _{TSD}	Thermal Shutdown Detection Temperature	Junction Temperature		165		°C
T _{TSR}	Thermal Shutdown Released Temperature	Junction Temperature		100		°C
R _{LOW}	LOW output Nch Tr. ON Resistance (RP111xxx1D only)	V _{IN} = 4.0 V, V _{CE} = 0 V		60		Ω

All test items listed under Electrical Characteristics are done under the pulse load condition (T_j ≈ T_a = 25°C) except for Load Transient Response.

The specifications surrounded by are guaranteed by design engineering at $-40^{\circ}\text{C} \leq T_a \leq 105^{\circ}\text{C}$.

RP111xxx1D/B (-AE) (Fixed Output Voltage Type) Dropout Voltage

($T_a = 25^{\circ}\text{C}$)

Output Voltage V_{OUT} (V)	Dropout Voltage V_{DIF} (V)		
	Condition	Typ.	Max.
$0.7 \leq V_{\text{SET}} < 0.8$	$I_{\text{OUT}} = 500 \text{ mA}$	0.58	0.88
$0.8 \leq V_{\text{SET}} < 0.9$		0.52	0.80
$0.9 \leq V_{\text{SET}} < 1.0$		0.45	0.70
$1.0 \leq V_{\text{SET}} < 1.2$		0.42	0.64
$1.2 \leq V_{\text{SET}} < 1.4$		0.35	0.53
$1.4 \leq V_{\text{SET}} < 1.8$		0.31	0.48
$1.8 \leq V_{\text{SET}} < 2.1$		0.27	0.44
$2.1 \leq V_{\text{SET}} < 2.5$		0.25	0.38
$2.5 \leq V_{\text{SET}} < 3.0$		0.23	0.34
$3.0 \leq V_{\text{SET}} \leq 3.6$		0.22	0.32

RP111x

NO.EC-241-200403

 $V_{IN} = 2.5\text{ V}$, $I_{OUT} = 1\text{ mA}$, $C_{IN} = C_{OUT} = 1.0\text{ }\mu\text{F}$, unless otherwise noted.The specifications surrounded by are guaranteed by design engineering at $-40^{\circ}\text{C} \leq T_a \leq 105^{\circ}\text{C}$.**RP111x001D/B (-AE) (Adjustable Output Voltage Type)**

(Ta = 25°C)

Symbol	Item	Conditions		Min.	Typ.	Max.	Unit
V_{FB}	Feedback pin output voltage	$T_a = 25^{\circ}\text{C}$	$V_{OUT} = V_{FB}$	0.682	0.700	0.718	V
		$-40^{\circ}\text{C} \leq T_a \leq 105^{\circ}\text{C}$		0.645		0.750	
V_{OUT}	Adjustable Output Voltage Range			0.7		3.6	V
I_{OUT}	Output Current			500			mA
$\Delta V_{OUT}/\Delta I_{OUT}$	Load regulation	$1\text{ mA} \leq I_{OUT} \leq 500\text{ mA}$			1	20	mV
V_{TRLD}	Load Transient Response	$I_{OUT}: 1\text{ mA} \Leftrightarrow 250\text{ mA}$ ($t_r = t_f = 0.5\text{ }\mu\text{s}$)	$C_{OUT} = 1\text{ }\mu\text{F}$		-75 +45		mV
			$C_{OUT} = 2.2\text{ }\mu\text{F}$		-55 +35		
		$I_{OUT}: 1\text{ mA} \Leftrightarrow 250\text{ mA}$ ($t_r = t_f = 5\text{ }\mu\text{s}$)	$C_{OUT} = 1\text{ }\mu\text{F}$		-20 +15		
V_{DIF}	Dropout Voltage	$V_{OUT} = V_{FB}$	$I_{OUT} = 500\text{ mA}$			0.88	V
I_{SS}	Supply Current	$I_{OUT} = 0\text{ mA}$			80	125	μA
$I_{standby}$	Standby Current	$V_{CE} = 0\text{ V}$			0.1	7.0	μA
$\Delta V_{OUT}/\Delta V_{IN}$	Line regulation	$V_{OUT} = V_{FB}$, $1.4\text{ V} \leq V_{IN} \leq 5.25\text{ V}$			0.02	0.10	%/V
I_{SC}	Short Current Limit	$V_{OUT} = V_{FB} = 0\text{ V}$			50		mA
I_{PD}	CE Pull-down Current				0.3	0.6	μA
V_{CEH}	CE Input Voltage "H"			1.0			V
V_{CEL}	CE Input Voltage "L"					0.4	V
T_{TSD}	Thermal Shutdown Detection Temperature	Junction Temperature			165		$^{\circ}\text{C}$
T_{TSR}	Thermal Shutdown Released Temperature	Junction Temperature			100		$^{\circ}\text{C}$

All test items listed under Electrical Characteristics are done under the pulse load condition ($T_j \approx T_a = 25^{\circ}\text{C}$) except for Load Transient Response.

$V_{IN} = V_{SET} + 1.0 \text{ V}$ ($V_{SET} > 1.5 \text{ V}$), $V_{IN} = 2.5 \text{ V}$ ($V_{SET} \leq 1.5 \text{ V}$), $I_{OUT} = 1 \text{ mA}$,
 $C_{IN} = C_{OUT} = 1.0 \mu\text{F}$, unless otherwise noted.

RP111xxx1D/B (-JE) (Fixed Output Voltage Type)

 ($-40^\circ\text{C} \leq T_a \leq 105^\circ\text{C}$)

Symbol	Item	Conditions	Min.	Typ.	Max.	Unit
V_{OUT}	Output voltage	$T_a = 25^\circ\text{C}$	$V_{SET} \geq 1.8 \text{ V}$	x 0.992	x 1.008	V
			$V_{SET} < 1.8 \text{ V}$	-18	18	mV
		$-40^\circ\text{C} \leq T_a \leq 105^\circ\text{C}$	$V_{SET} \geq 1.8 \text{ V}$	x 0.985	x 1.015	V
			$V_{SET} < 1.8 \text{ V}$	-55	50	mV
I_{OUT}	Output Current		500			mA
$\Delta V_{OUT}/\Delta I_{OUT}$	Load regulation	$1 \text{ mA} \leq I_{OUT} \leq 500 \text{ mA}$		1	20	mV
V_{TRLD}	Load Transient Response	$I_{OUT}: 1 \text{ mA} \leftrightarrow 250 \text{ mA}$ ($t_r = t_f = 0.5 \mu\text{s}$)	$C_{OUT} = 1 \mu\text{F}$	-75	+45	mV
			$C_{OUT} = 2.2 \mu\text{F}$	-55	+35	
		$I_{OUT}: 1 \text{ mA} \leftrightarrow 250 \text{ mA}$ ($t_r = t_f = 5 \mu\text{s}$)	$C_{OUT} = 1 \mu\text{F}$	-20	+15	
V_{DIF}	Dropout Voltage	Refer to the <i>Dropout Voltage</i>				
I_{SS}	Supply Current	$I_{OUT} = 0 \text{ mA}$		80	125	μA
$I_{standby}$	Standby Current	$V_{CE} = 0 \text{ V}$		0.1	7.0	μA
$\Delta V_{OUT}/\Delta V_{IN}$	Line regulation	$V_{SET} + 0.5 \text{ V} \leq V_{IN} \leq 5.25 \text{ V}$, $V_{IN} \geq 1.4 \text{ V}$		0.02	0.10	%/V
I_{SC}	Short Current Limit	$V_{OUT} = 0 \text{ V}$		50		mA
I_{PD}	CE Pull-down Current			0.3	0.6	μA
V_{CEH}	CE Input Voltage "H"		1.0			V
V_{CEL}	CE Input Voltage "L"				0.4	V
T_{TSD}	Thermal Shutdown Detection Temperature	Junction Temperature		165		$^\circ\text{C}$
T_{TSR}	Thermal Shutdown Released Temperature	Junction Temperature		100		$^\circ\text{C}$
R_{LOW}	LOW output Nch Tr. ON Resistance (RP111xxxD only)	$V_{IN} = 4.0 \text{ V}$, $V_{CE} = 0 \text{ V}$		60		Ω

All test items listed under Electrical Characteristics are done under the pulse load condition ($T_j \approx T_a = 25^\circ\text{C}$) except for Load Transient Response.

RP111x

NO.EC-241-200403

RP111xxx1D/B (-JE) (Fixed Output Voltage Type) Dropout Voltage

(-40°C ≤ Ta ≤ 105°C)

Output Voltage V _{OUT} (V)	Dropout Voltage V _{DIF} (V)		
	Condition	Typ.	Max.
0.7 ≤ V _{SET} < 0.8	I _{OUT} = 500 mA	0.58	0.88
0.8 ≤ V _{SET} < 0.9		0.52	0.80
0.9 ≤ V _{SET} < 1.0		0.45	0.70
1.0 ≤ V _{SET} < 1.2		0.42	0.64
1.2 ≤ V _{SET} < 1.4		0.35	0.53
1.4 ≤ V _{SET} < 1.8		0.31	0.48
1.8 ≤ V _{SET} < 2.1		0.27	0.44
2.1 ≤ V _{SET} < 2.5		0.25	0.38
2.5 ≤ V _{SET} < 3.0		0.23	0.34
3.0 ≤ V _{SET} ≤ 3.6		0.22	0.32

$V_{IN} = 2.5\text{ V}$, $I_{OUT} = 1\text{ mA}$, $C_{IN} = C_{OUT} = 1.0\text{ }\mu\text{F}$, unless otherwise noted.

RP111x001D/B (-JE) (Adjustable Output Voltage Type)

 ($-40^{\circ}\text{C} \leq T_a \leq 105^{\circ}\text{C}$)

Symbol	Item	Conditions		Min.	Typ.	Max.	Unit
V_{FB}	Feedback pin output voltage	$T_a = 25^{\circ}\text{C}$	$V_{OUT} = V_{FB}$	0.682	0.700	0.718	V
		$-40^{\circ}\text{C} \leq T_a \leq 105^{\circ}\text{C}$		0.645		0.750	
V_{OUT}	Adjustable Output Voltage Range			0.7		3.6	V
I_{OUT}	Output Current			500			mA
$\Delta V_{OUT}/\Delta I_{OUT}$	Load regulation	$1\text{ mA} \leq I_{OUT} \leq 500\text{ mA}$			1	20	mV
V_{TRLD}	Load Transient Response	$I_{OUT}: 1\text{ mA} \leftrightarrow 250\text{ mA}$ ($t_r = t_f = 0.5\text{ }\mu\text{s}$)	$C_{OUT} = 1\text{ }\mu\text{F}$		-75 +45		mV
			$C_{OUT} = 2.2\text{ }\mu\text{F}$		-55 +35		
		$I_{OUT}: 1\text{ mA} \leftrightarrow 250\text{ mA}$ ($t_r = t_f = 5\text{ }\mu\text{s}$)	$C_{OUT} = 1\text{ }\mu\text{F}$		-20 +15		
V_{DIF}	Dropout Voltage	$V_{OUT} = V_{FB}$	$I_{OUT} = 500\text{ mA}$			0.88	V
I_{SS}	Supply Current	$I_{OUT} = 0\text{ mA}$			80	125	μA
$I_{standby}$	Standby Current	$V_{CE} = 0\text{ V}$			0.1	7.0	μA
$\Delta V_{OUT}/\Delta V_{IN}$	Line regulation	$V_{OUT} = V_{FB}$, $1.4\text{ V} \leq V_{IN} \leq 5.25\text{ V}$			0.02	0.10	%/V
I_{SC}	Short Current Limit	$V_{OUT} = V_{FB} = 0\text{ V}$			50		mA
I_{PD}	CE Pull-down Current				0.3	0.6	μA
V_{CEH}	CE Input Voltage "H"			1.0			V
V_{CEL}	CE Input Voltage "L"					0.4	V
T_{TSD}	Thermal Shutdown Detection Temperature	Junction Temperature			165		$^{\circ}\text{C}$
T_{TSR}	Thermal Shutdown Released Temperature	Junction Temperature			100		$^{\circ}\text{C}$

All test items listed under Electrical Characteristics are done under the pulse load condition ($T_j \approx T_a = 25^{\circ}\text{C}$) except for Load Transient Response.

TYPICAL APPLICATIONS

Internally Fixed Output Voltage

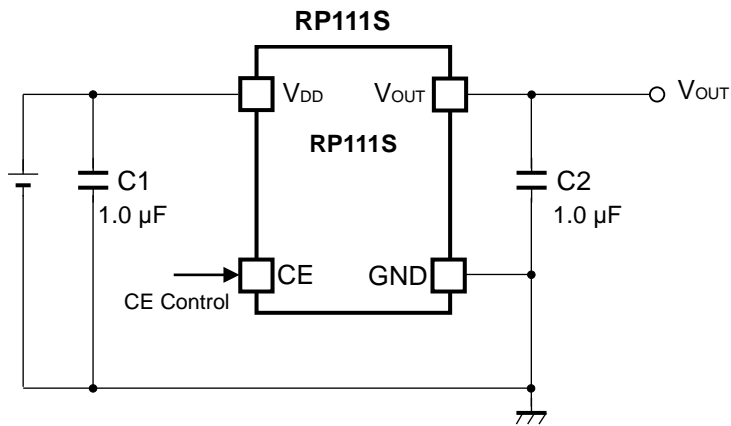
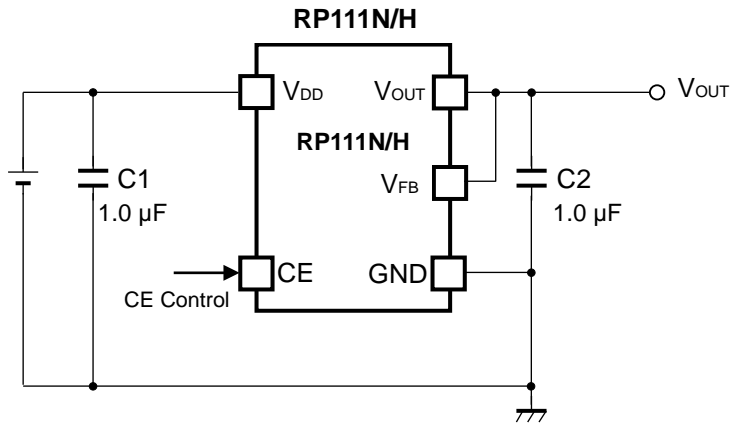

Externally Adjustable Output Voltage

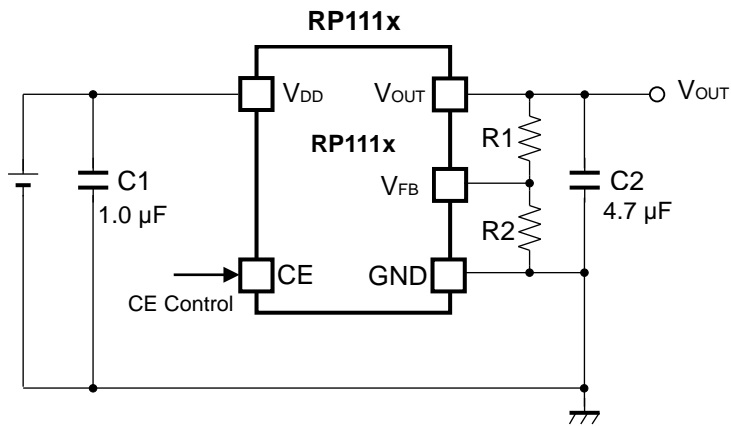

TECHNICAL NOTES

Phase Compensation

In this device, phase compensation is made for securing stable operation even if the load current is varied. For this purpose, use a 1.0 μF or more capacitor C2.

In case of using a tantalum capacitor, and its ESR is large, the output may be unstable. Therefore, select C2 carefully considering its frequency characteristics.

When using the Adjustable Output Voltage Type, set 4.7 μF or more of the output capacitor C2 as close as possible to the device, and make wiring as short as possible.

PCB Layout

Make V_{DD} and GND lines sufficient. If their impedance is high, noise pickup or unstable operation may result.

Connect a capacitor C1 with a capacitance value as much as 1.0 μF or more between V_{DD} and GND pin, and as close as possible to the pins.

Set external components, especially the output capacitor C2, as close as possible to the device, and make wiring as short as possible (Refer to *TYPICAL APPLICATIONS*).

Transient Response

When using the Adjustable Output Voltage Type, the transient response could be affected by the external resistors. Evaluate the circuit taking the actual conditions of use into account.

TYPICAL APPLICATION FOR IC CHIP BREAKDOWN PREVENTION

Internally Fixed Output Voltage

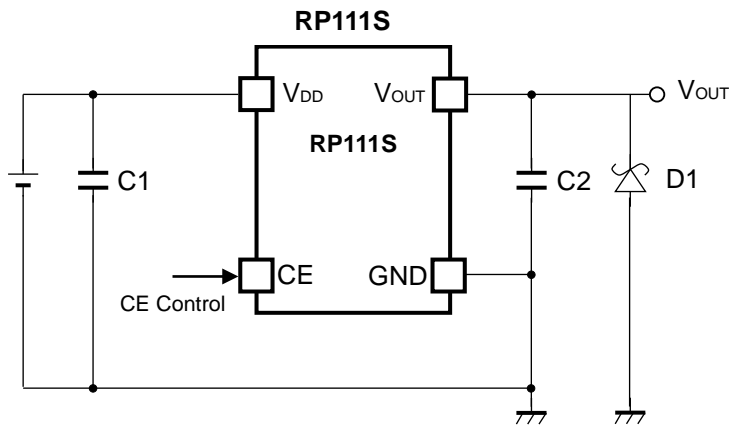
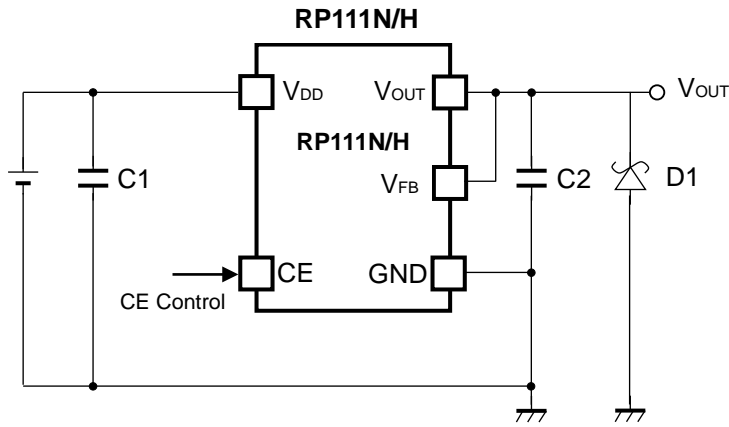

Externally Adjustable Output Voltage

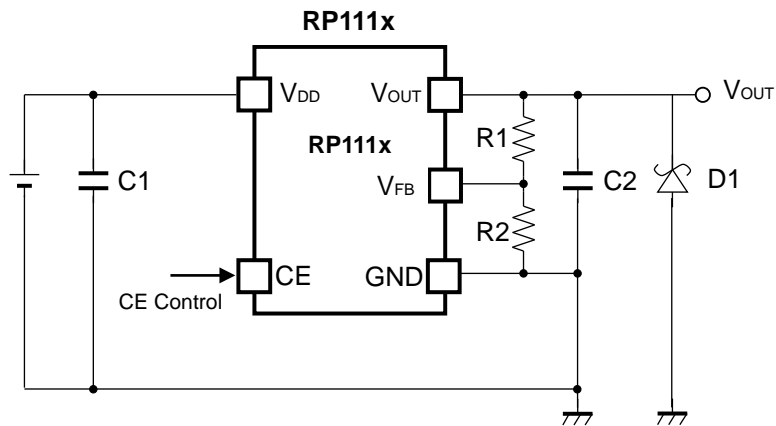

When a sudden surge of electrical current travels along the V_{OUT} pin and GND due to a short-circuit, electrical resonance of a circuit involving an output capacitor (C2) and a short circuit inductor generates a negative voltage and may damage the device or the load devices. Connecting a schottky diode (D1) between the V_{OUT} pin and GND has the effect of preventing damage to them.

ADJUSTABLE OUTPUT VOLTAGE SETTING

Output Voltage Setting

RP111x is capable of adjusting the output voltage by using the external divider resistors.

If the V_{FB} voltage fixed in the device is described as $setV_{FB}$, the output voltage can be set by using the following formulas.

$$I_1 = I_{IC} + I_2 \dots\dots\dots (1)$$

$$I_2 = setV_{FB} / R_2 \dots\dots\dots (2)$$

Thus,

$$I_1 = I_{IC} + setV_{FB} / R_2 \dots\dots\dots (3)$$

Therefore,

$$V_{OUT} = setV_{FB} + R_1 \times I_1 \dots\dots\dots (4)$$

Put formula (3) into formula (4), then

$$\begin{aligned} V_{OUT} &= setV_{FB} + R_1 \times (I_{IC} + setV_{FB} / R_2) \\ &= setV_{FB} \times (1 + R_1/R_2) + R_1 \times I_{IC} \dots\dots\dots (5) \end{aligned}$$

In formula (5), $R_1 \times I_{IC}$ is the error-causing factor in V_{OUT} .

As for I_{IC} ,

$$I_{IC} = setV_{FB} / R_{IC} \dots\dots\dots (6)$$

Therefore, the error-causing factor $R_1 \times I_{IC}$ can be described as follows.

$$\begin{aligned} R_1 \times I_{IC} &= R_1 \times setV_{FB} / R_{IC} \\ &= setV_{FB} \times R_1 / R_{IC} \dots\dots\dots (7) \end{aligned}$$

For better accuracy, choosing $R_1 \ll R_{IC}$ reduces this error.

Without the error-causing factor $R_1 \times I_{IC}$, the output voltage can be calculated by the following formula.

$$V_{OUT} = setV_{FB} \times ((R_1 + R_2) / R_2) \dots\dots\dots (8)$$

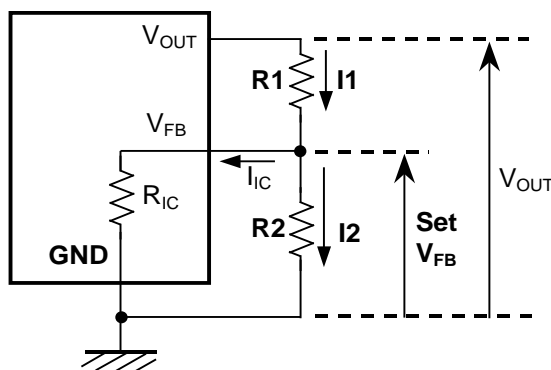

The output voltage of the externally adjustable output voltage type should be set to 3.6 V or less.

The resistance of R_2 should be 16 k Ω or less.

TRANSIENT RESPONSE

The RP111x has been improved in overall output voltage characteristics including temperature and transient response. The load transient response indicated under the Electrical Characteristics is guaranteed by design based on the condition when I_{OUT} changes from 1 mA to 250 mA or 250 mA to 1 mA. The output voltage variations under the other load conditions, the characteristic examples are shown below.

RP111x151x

$V_{IN} = 2.5\text{ V}$, $-40^{\circ}\text{C} \leq T_a \leq 85^{\circ}\text{C}$

$C_{IN} = 1.0\ \mu\text{F}$, $C_{OUT} = 1.0\ \mu\text{F}$, $I_{OUT} = 1\ \text{mA} \leftrightarrow$ Peak Output Current

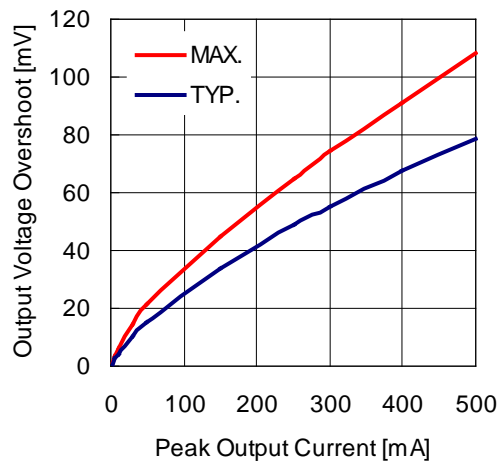
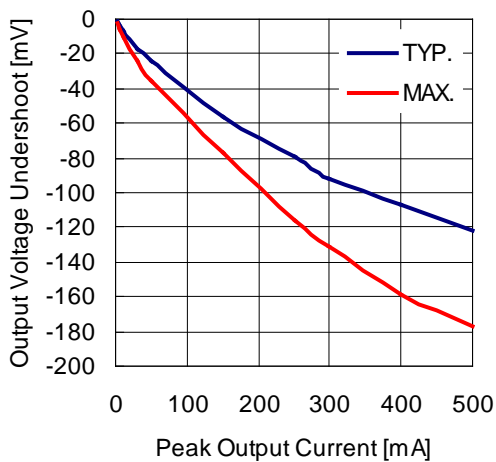

$C_{IN} = 1.0\ \mu\text{F}$, $C_{OUT} = 2.2\ \mu\text{F}$, $I_{OUT} = 1\ \text{mA} \leftrightarrow$ Peak Output Current

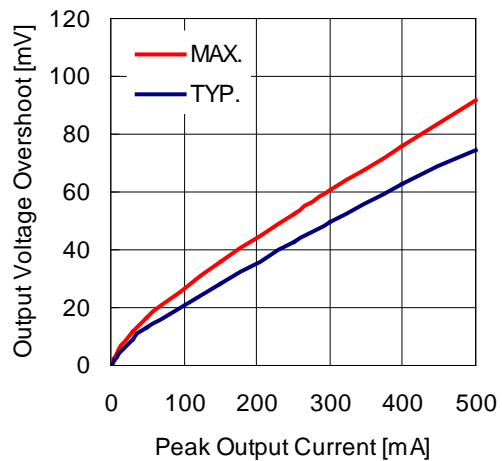
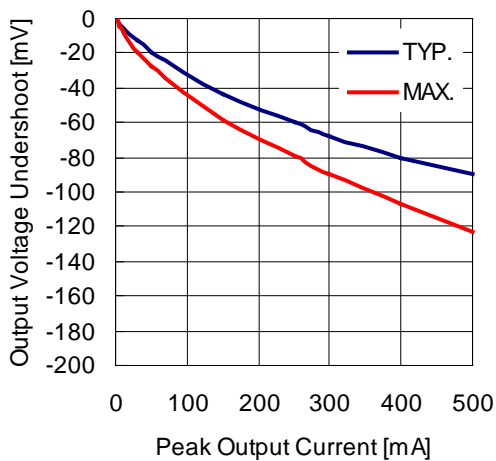

$C_{IN} = 1.0 \mu F, C_{OUT} = 1.0 \mu F, I_{OUT} = 1 \text{ mA} \leftrightarrow \text{Peak Output Current}$

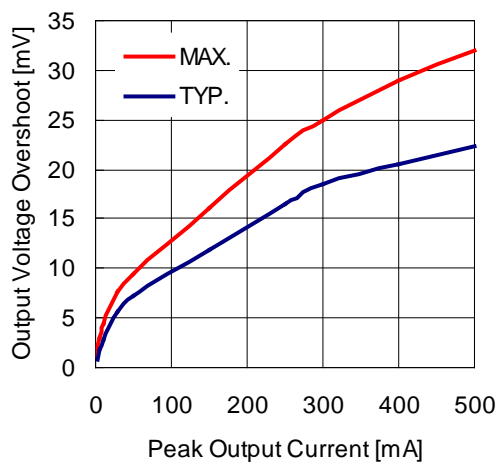
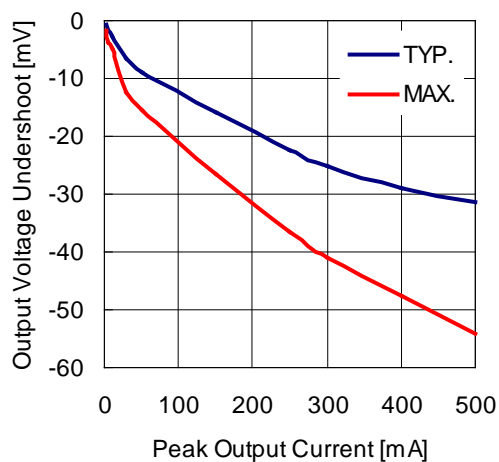

RP111x281x

$V_{IN} = 3.8 \text{ V}, -40^{\circ}\text{C} \leq T_a \leq 85^{\circ}\text{C}$

$C_{IN} = 1.0 \mu F, C_{OUT} = 1.0 \mu F, I_{OUT} = 1 \text{ mA} \leftrightarrow \text{Peak Output Current}$

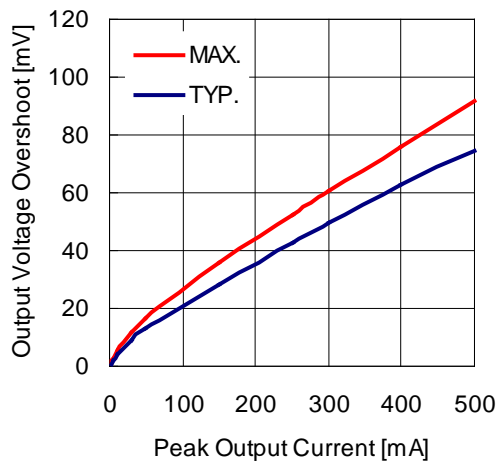
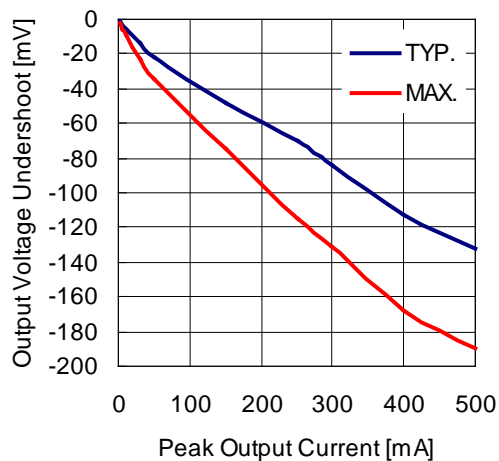

$C_{IN} = 1.0 \mu F, C_{OUT} = 2.2 \mu F, I_{OUT} = 1 \text{ mA} \leftrightarrow \text{Peak Output Current}$

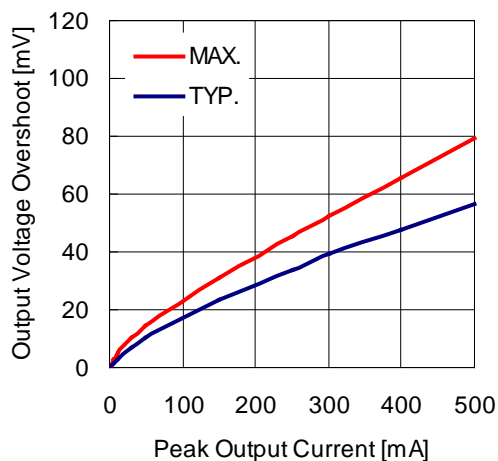
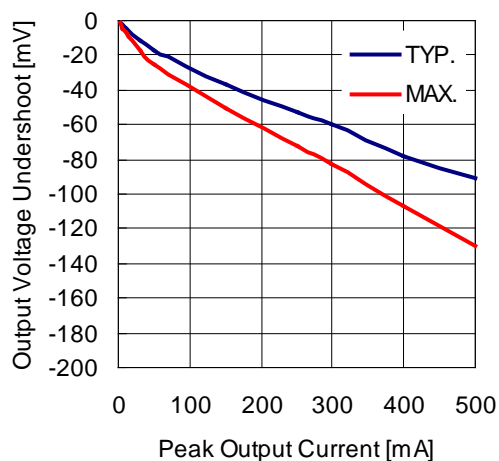

$C_{IN} = 1.0 \mu F, C_{OUT} = 1.0 \mu F, I_{OUT} = 1 \text{ mA} \leftrightarrow \text{Peak Output Current}$

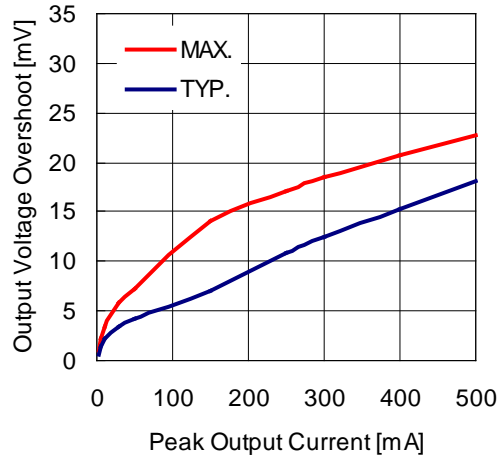
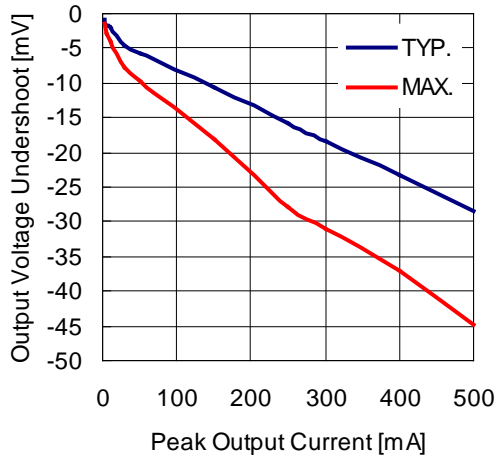

Input Transient Response has the output voltage dependency. Please refer to the characteristic examples below.

$V_{IN}: V_{SET} + 0.5 \text{ V} \leftrightarrow V_{SET} + 1.5 \text{ V} (tr = tf = 5.0 \mu s), V_{IN} \geq 1.4 \text{ V},$
 $C_{OUT} = 1.0 \mu F, I_{OUT} = 30 \text{ mA}$

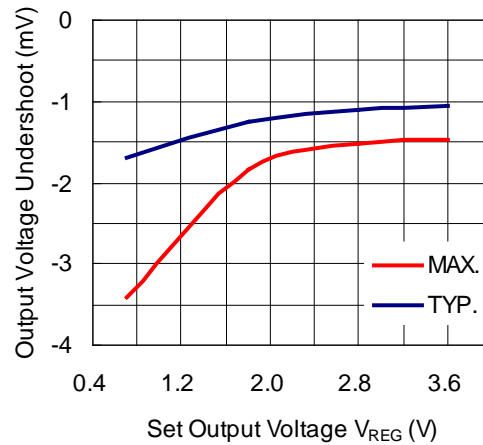
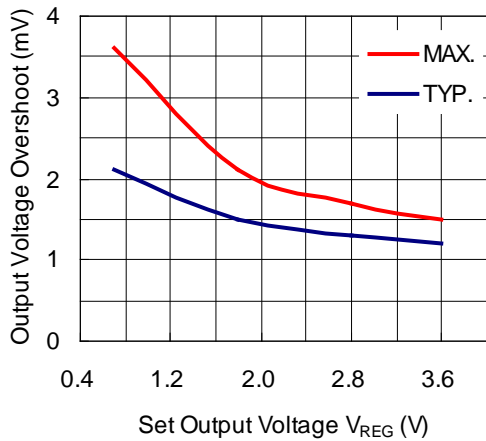

The graphs shown above are reference data.

For the better transient response, a capacitor with higher capacitance is recommended and the wire impedance of GND and V_{OUT} should be minimized as possible.

The transient response characteristics depend on the external parts and PCB layout. Therefore, the operating conditions for the transient response in the application should be considered and evaluation is necessary.

PACKAGE INFORMATION

P POWER DISSIPATION (SOT-23-5)

The power dissipation of the package is dependent on PCB material, layout, and environmental conditions. The following measurement conditions are based on JEDEC STD. 51-7.

Measurement Conditions

Item	Measurement Conditions
Environment	Mounting on Board (Wind Velocity = 0 m/s)
Board Material	Glass Cloth Epoxy Plastic (Four-Layer Board)
Board Dimensions	76.2 mm × 114.3 mm × 0.8 mm
Copper Ratio	Outer Layer (First Layer): Less than 95% of 50 mm Square Inner Layers (Second and Third Layers): Approx. 100% of 50 mm Square Outer Layer (Fourth Layer): Approx. 100% of 50 mm Square
Through-holes	φ 0.3 mm × 7 pcs

Measurement Result

(Ta = 25°C, Tjmax = 150°C)

Item	Measurement Result
Power Dissipation	830 mW
Thermal Resistance (θja)	θja = 150°C/W
Thermal Characterization Parameter (ψjt)	ψjt = 51°C/W

θja: Junction-to-Ambient Thermal Resistance

ψjt: Junction-to-Top Thermal Characterization Parameter

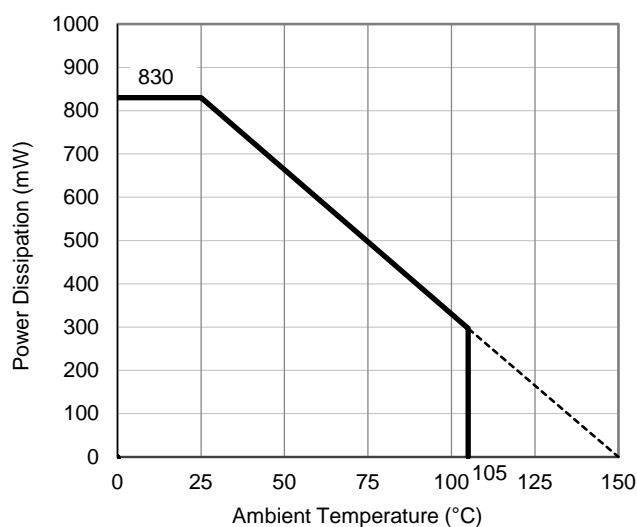

Power Dissipation vs. Ambient Temperature

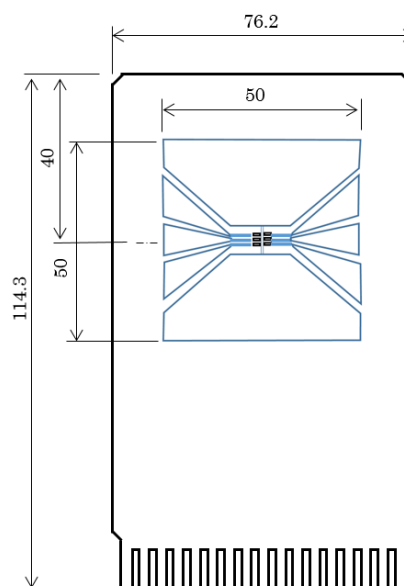

Measurement Board Pattern

RP111x

NO.EC-241-200403

PACKAGE DIMENSIONS (SOT-23-5)

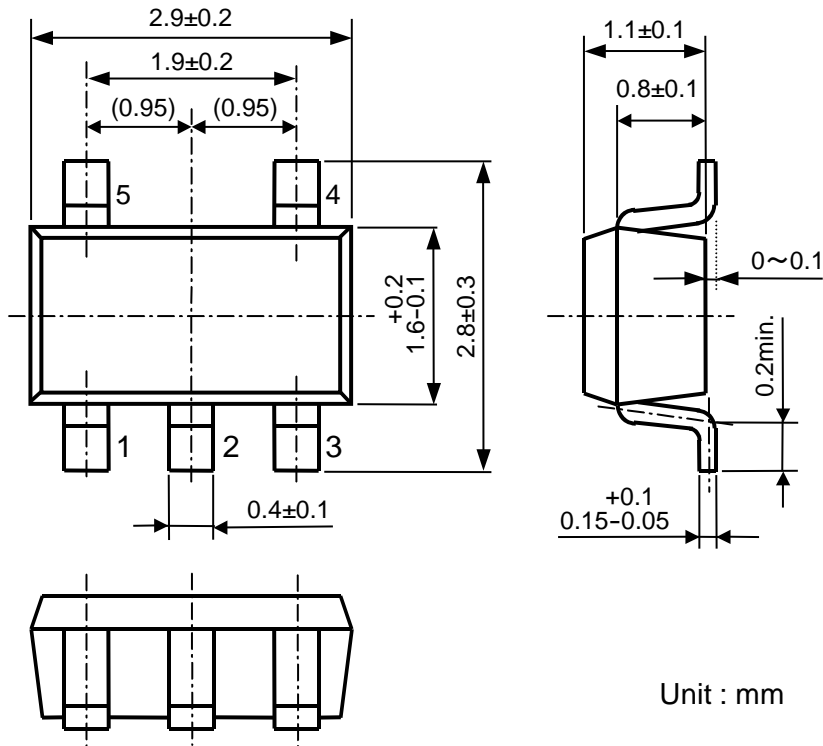

Unit : mm

MARK SPECIFICATION (SOT-23-5)

①②③: Product Code ... **Refer to *MARK SPECIFICATION TABLE (SOT-23-5)***

④⑤: Lot Number ... Alphanumeric Serial Number

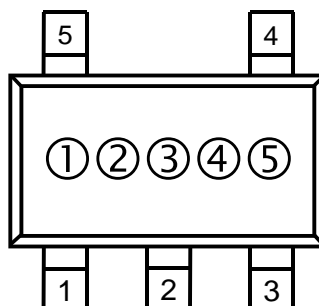

NOTICE

There can be variation in the marking when different AOI (Automated Optical Inspection) equipment is used. In the case of recognizing the marking characteristic with AOI, please contact RICOH sales or our distributor before attempting to use AOI.

MARK SPECIFICATION TABLE (SOT-23-5)

RP111Nxx1B

Product Name	①	②	③	V _{SET}
RP111N071B	H	0	7	0.7 V
RP111N121B	H	1	2	1.2 V
RP111N151B	H	1	5	1.5 V
RP111N181B	H	1	8	1.8 V
RP111N251B	H	2	5	2.5 V
RP111N281B	H	2	8	2.8 V
RP111N281B5	H	4	0	2.85 V
RP111N291B	H	2	9	2.9 V
RP111N301B	H	3	0	3.0 V
RP111N331B	H	3	3	3.3 V
RP111N341B	H	3	4	3.4 V

RP111Nxx1D

Product Name	①	②	③	V _{SET}
RP111N071D	J	0	7	0.7 V
RP111N121D	J	1	2	1.2 V
RP111N151D	J	1	5	1.5 V
RP111N181D	J	1	8	1.8 V
RP111N251D	J	2	5	2.5 V
RP111N281D	J	2	8	2.8 V
RP111N281D5	J	4	0	2.85 V
RP111N291D	J	2	9	2.9 V
RP111N301D	J	3	0	3.0 V
RP111N331D	J	3	3	3.3 V
RP111N341D	J	3	4	3.4 V

RP111N001B (Adjustable Output Voltage Type)

Product Name	①	②	③	V _{SET}
RP111N001B	H	0	0	-

RP111N001D (Adjustable Output Voltage Type)

Product Name	①	②	③	V _{SET}
RP111N001D	J	0	0	-

RP111x

NO.EC-241-200403

POWER DISSIPATION (SOT-89-5)

The power dissipation of the package is dependent on PCB material, layout, and environmental conditions. The following measurement conditions are based on JEDEC STD. 51-7.

Measurement Conditions

Item	Measurement Conditions
Environment	Mounting on Board (Wind Velocity = 0 m/s)
Board Material	Glass Cloth Epoxy Plastic (Four-Layer Board)
Board Dimensions	76.2 mm x 114.3 mm x 0.8 mm
Copper Ratio	Outer Layer (First Layer): Less than 95% of 50 mm Square Inner Layers (Second and Third Layers): Approx. 100% of 50 mm Square Outer Layer (Fourth Layer): Approx. 100% of 50 mm Square
Through-holes	φ 0.3 mm x 13 pcs

Measurement Result

(Ta = 25°C, Tjmax = 150°C)

Item	Measurement Result
Power Dissipation	3200 mW
Thermal Resistance (θja)	θja = 38°C/W
Thermal Characterization Parameter (ψjt)	ψjt = 13°C/W

θja: Junction-to-Ambient Thermal Resistance

ψjt: Junction-to-Top Thermal Characterization Parameter

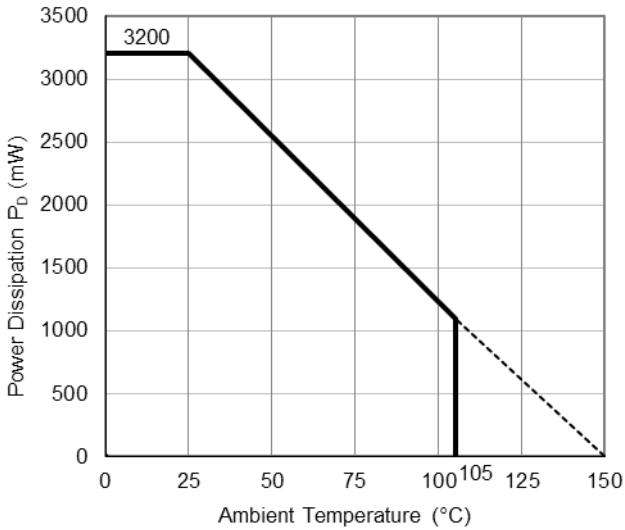

Power Dissipation vs. Ambient Temperature

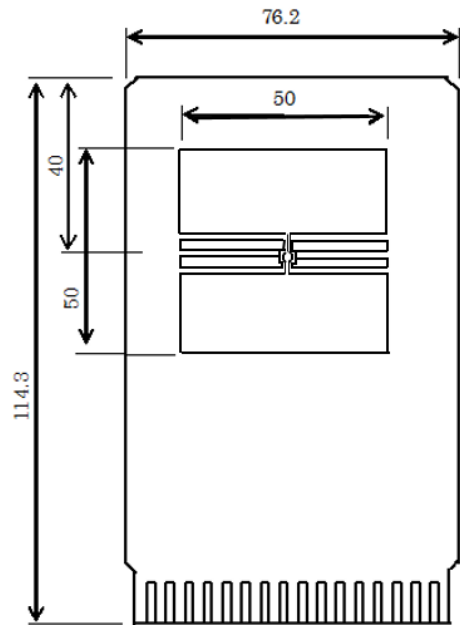

Measurement Board Pattern

RP111x

NO.EC-241-200403

MARK SPECIFICATION (SOT-89-5)

①②③④: Product Code ... **Refer to MARK SPECIFICATION TABLE (SOT-89-5)**

⑤⑥: Lot Number ... Alphanumeric Serial Number

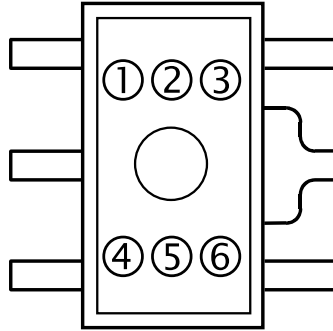

NOTICE

There can be variation in the marking when different AOI (Automated Optical Inspection) equipment is used. In the case of recognizing the marking characteristic with AOI, please contact RICOH sales or our distributor before attempting to use AOI.

MARK SPECIFICATION TABLE (SOT-89-5)

RP111Hxx1B

Product Name	① ② ③ ④	V _{SET}
RP111H071B	A 0 7 B	0.7 V
RP111H121B	A 1 2 B	1.2 V
RP111H151B	A 1 5 B	1.5 V
RP111H181B	A 1 8 B	1.8 V
RP111H251B	A 2 5 B	2.5 V
RP111H281B	A 2 8 B	2.8 V
RP111H281B5	A 4 0 B	2.85 V
RP111H291B	A 2 9 B	2.9 V
RP111H301B	A 3 0 B	3.0 V
RP111H331B	A 3 3 B	3.3 V
RP111H341B	A 3 4 B	3.4 V

RP111Hxx1D

Product Name	① ② ③ ④	V _{SET}
RP111H071D	A 0 7 D	0.7 V
RP111H121D	A 1 2 D	1.2 V
RP111H151D	A 1 5 D	1.5 V
RP111H181D	A 1 8 D	1.8 V
RP111H251D	A 2 5 D	2.5 V
RP111H281D	A 2 8 D	2.8 V
RP111H281D5	A 4 0 D	2.85 V
RP111H291D	A 2 9 D	2.9 V
RP111H301D	A 3 0 D	3.0 V
RP111H331D	A 3 3 D	3.3 V
RP111H341D	A 3 4 D	3.4 V

RP111H001B (Adjustable Output Voltage Type)

Product Name	① ② ③ ④	V _{SET}
RP111H001B	A 0 0 B	-

RP111H001D (Adjustable Output Voltage Type)

Product Name	① ② ③ ④	V _{SET}
RP111H001D	A 0 0 D	-

POWER DISSIPATION (HSOP-6J)

The power dissipation of the package is dependent on PCB material, layout, and environmental conditions. The following measurement conditions are based on JEDEC STD. 51-7.

Measurement Conditions

Item	Measurement Conditions
Environment	Mounting on Board (Wind Velocity = 0 m/s)
Board Material	Glass Cloth Epoxy Plastic (Four-Layer Board)
Board Dimensions	76.2 mm × 114.3 mm × 0.8 mm
Copper Ratio	Outer Layer (First Layer): Less than 95% of 50 mm Square Inner Layers (Second and Third Layers): Approx. 100% of 50 mm Square Outer Layer (Fourth Layer): Approx. 100% of 50 mm Square
Through-holes	φ 0.3 mm × 28 pcs

Measurement Result

(Ta = 25°C, Tjmax = 150°C)

Item	Measurement Result
Power Dissipation	3400 mW
Thermal Resistance (θja)	θja = 37°C/W
Thermal Characterization Parameter (ψjt)	ψjt = 7°C/W

θja: Junction-to-Ambient Thermal Resistance

ψjt: Junction-to-Top Thermal Characterization Parameter

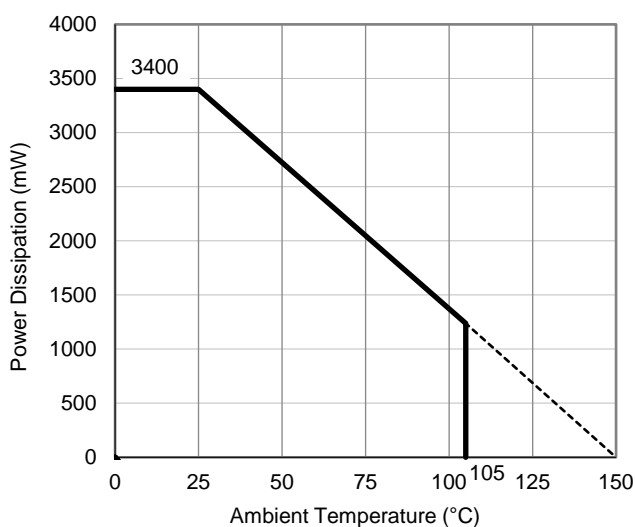

Power Dissipation vs. Ambient Temperature

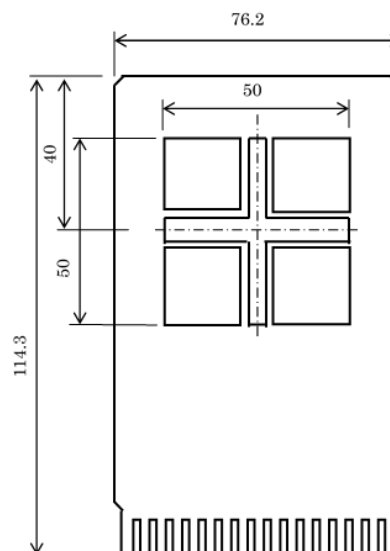

Measurement Board Pattern

RP111x

NO.EC-241-200403

PACKAGE DIMENSIONS (HSOP-6J)

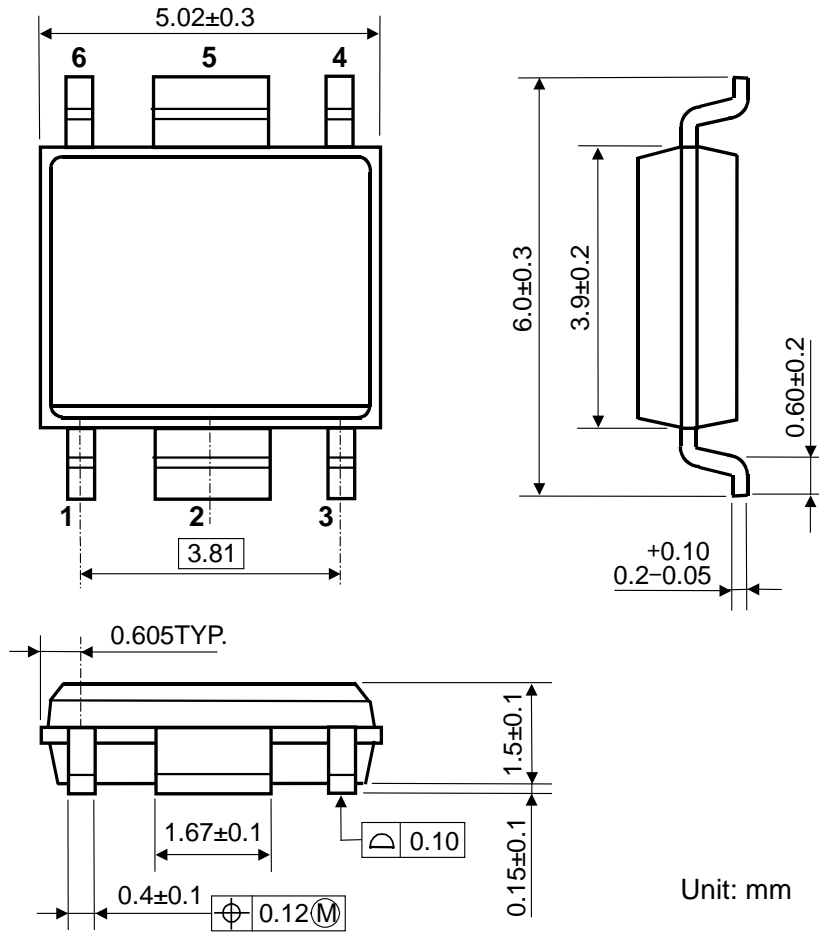

Unit: mm

MARK SPECIFICATION (HSOP-6J)

①②③④: Product Code ... **Refer to MARK SPECIFICATION TABLE (HSOP-6J)**

⑤⑥: Lot Number ... Alphanumeric Serial Number

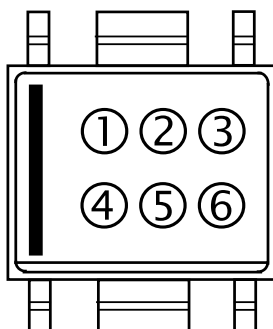

MARK SPECIFICATION TABLE (HSOP-6J)

RP111Sxx1B

Product Name	① ② ③ ④	V _{SET}
RP111S071B	C 0 7 B	0.7 V
RP111S121B	C 1 2 B	1.2 V
RP111S151B	C 1 5 B	1.5 V
RP111S181B	C 1 8 B	1.8 V
RP111S251B	C 2 5 B	2.5 V
RP111S281B	C 2 8 B	2.8 V
RP111S281B5	C 4 0 B	2.85 V
RP111S291B	C 2 9 B	2.9 V
RP111S301B	C 3 0 B	3.0 V
RP111S331B	C 3 3 B	3.3 V
RP111S341B	C 3 4 B	3.4 V

RP111Sxx1D

Product Name	① ② ③ ④	V _{SET}
RP111S071D	C 0 7 D	0.7 V
RP111S121D	C 1 2 D	1.2 V
RP111S151D	C 1 5 D	1.5 V
RP111S181D	C 1 8 D	1.8 V
RP111S251D	C 2 5 D	2.5 V
RP111S281D	C 2 8 D	2.8 V
RP111S281D5	C 4 0 D	2.85 V
RP111S291D	C 2 9 D	2.9 V
RP111S301D	C 3 0 D	3.0 V
RP111S331D	C 3 3 D	3.3 V
RP111S341D	C 3 4 D	3.4 V

RP111S001B (Adjustable Output Voltage Type)

Product Name	① ② ③ ④	V _{SET}
RP111S001B	C 0 0 B	-

RP111S001D (Adjustable Output Voltage Type)

Product Name	① ② ③ ④	V _{SET}
RP111S001D	C 0 0 D	-

TYPICAL CHARACTERISTICS

Note: Typical Characteristics are intended to be used as reference data; they are not guaranteed.

1) Output Voltage vs. Output Current (C1 = Ceramic 1.0 μ F, C2 = Ceramic 1.0 μ F, Ta = 25°C)

RP111x071x

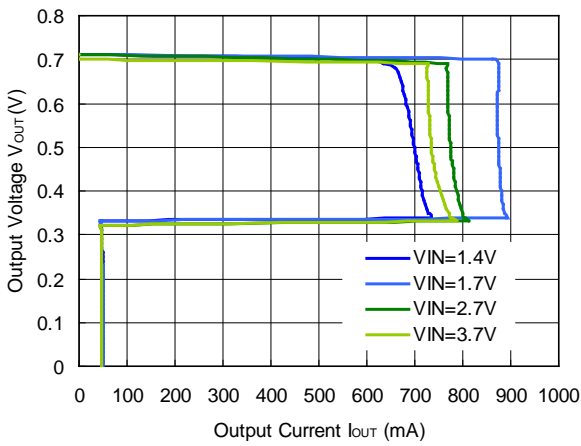

RP111x171x

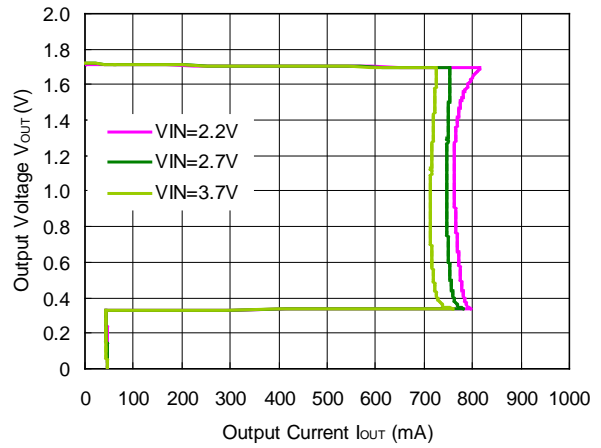

RP111x181x

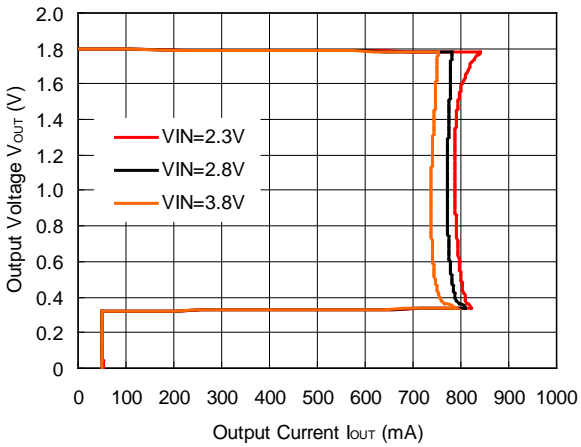

RP111x281x

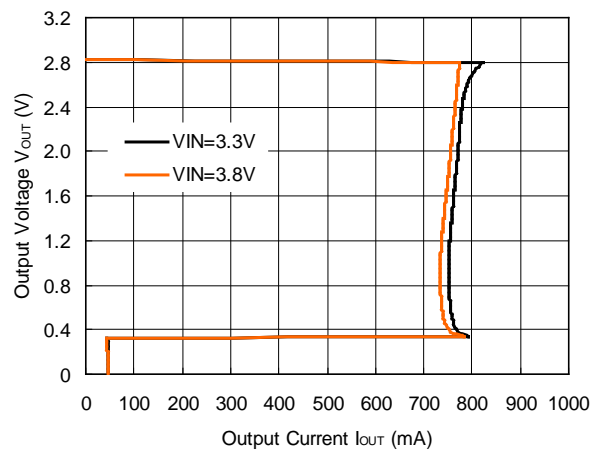

RP111x361x

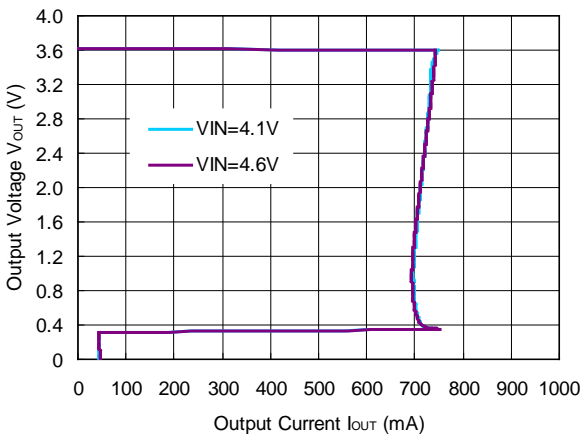

2) Output Voltage vs. Input Voltage (C1 = Ceramic 1.0 μ F, C2 = Ceramic 1.0 μ F, Ta = 25°C)

RP111x071x

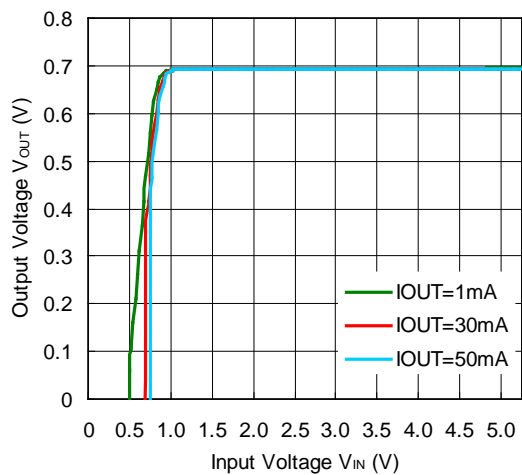

RP111x171x

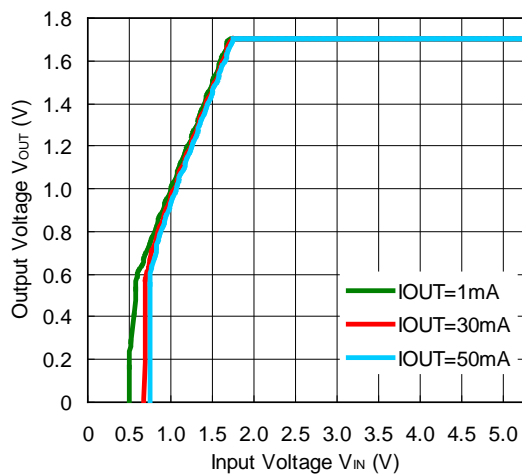

RP111x181x

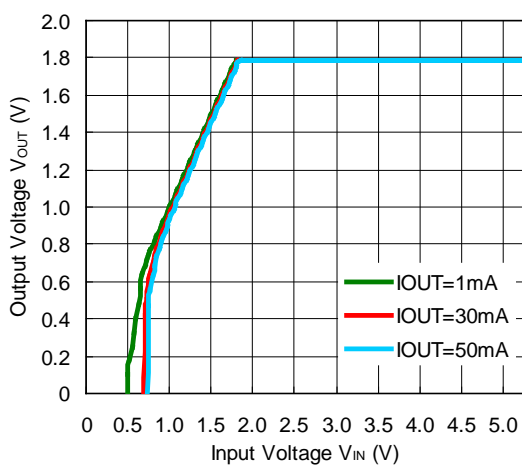

RP111x281x

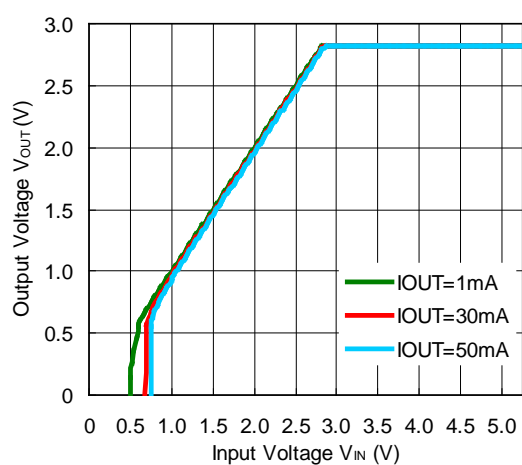

RP111x361x

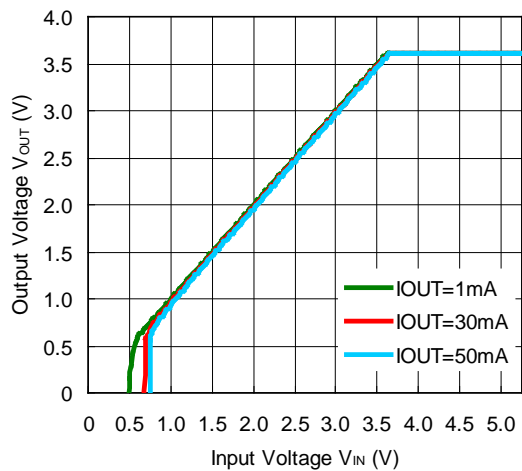

3) Supply Current vs. Input Voltage (C1 = Ceramic 1.0 μ F, C2 = Ceramic 1.0 μ F, Ta = 25°C)

RP111x071x

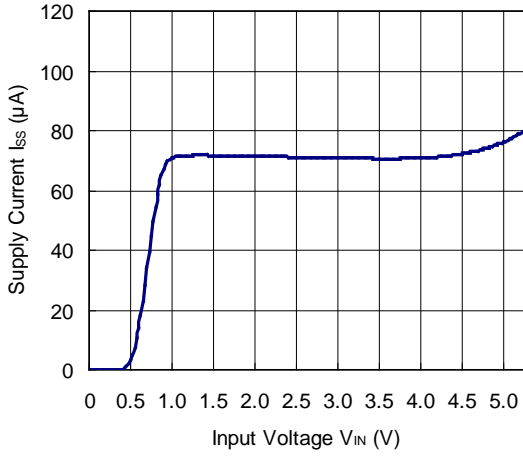

RP111x171x

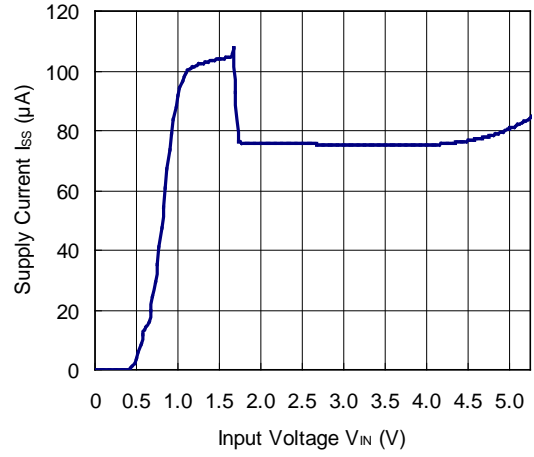

RP111x181x

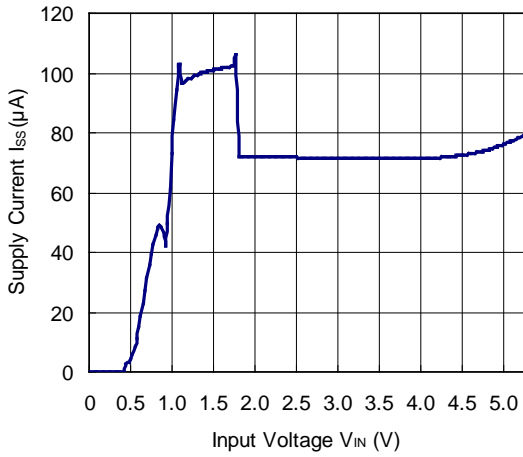

RP111x281x

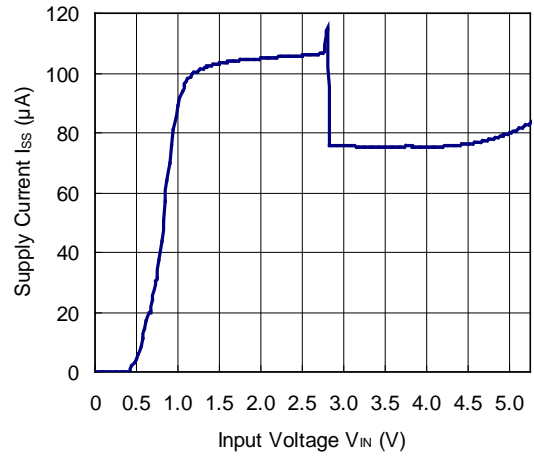

RP111x361x

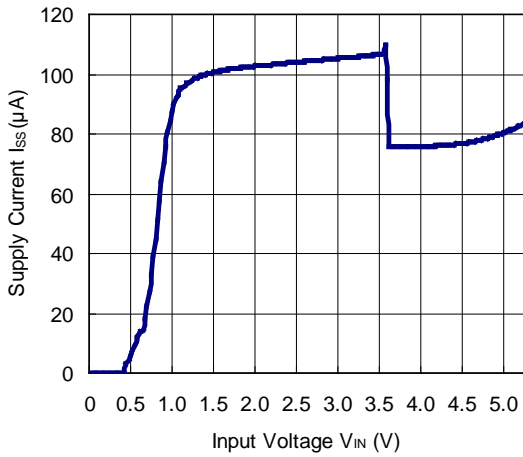

4) Output Voltage vs. Temperature (C1 = Ceramic 1.0 μ F, C2 = Ceramic 1.0 μ F, I_{OUT} = 1 mA)

RP111x071x

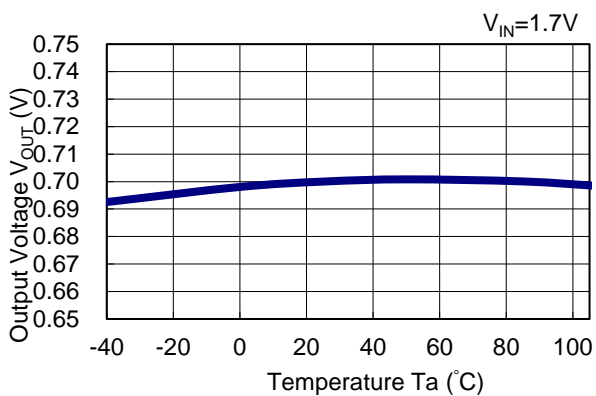

RP111x171x

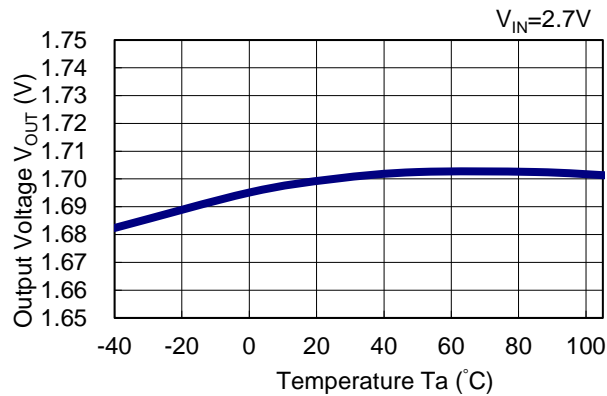

RP111x181x

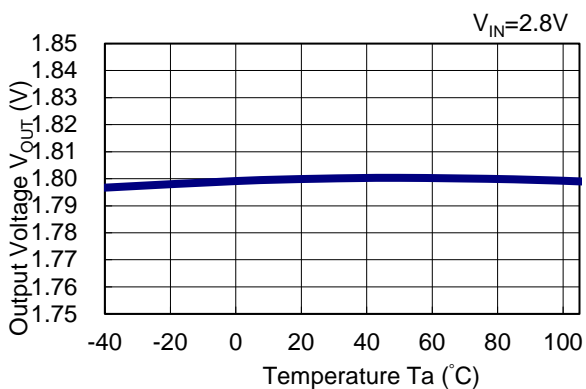

RP111x281x

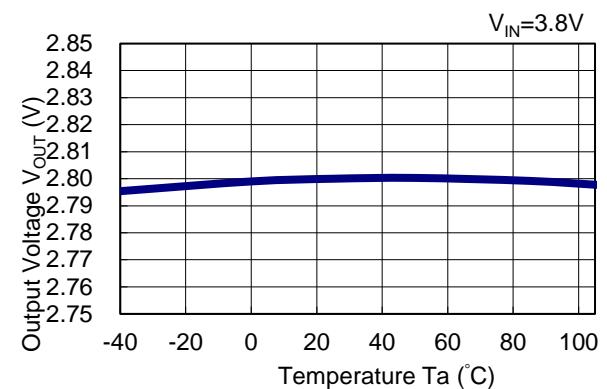

RP111x361x

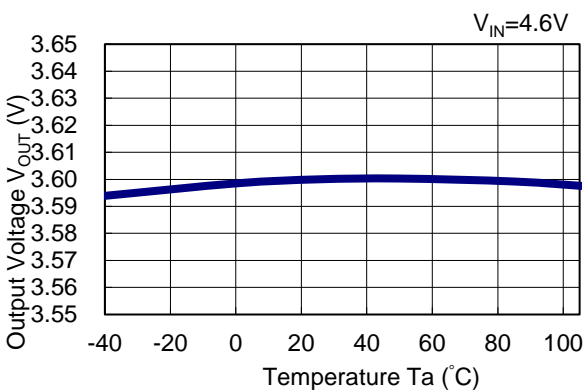

RP111xNO.EC-241-200403

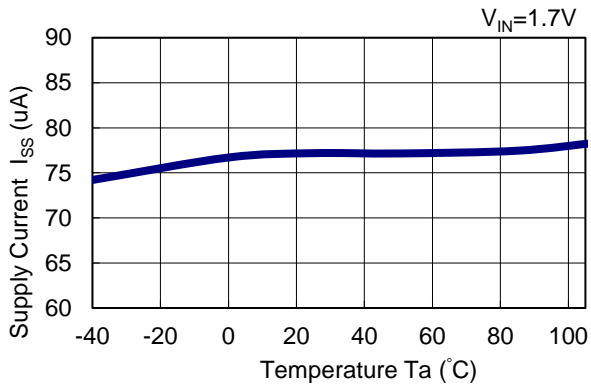
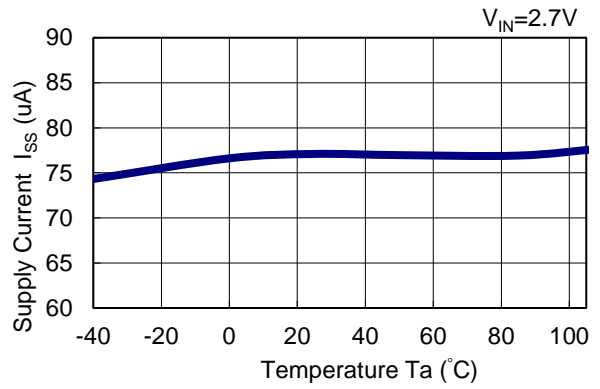
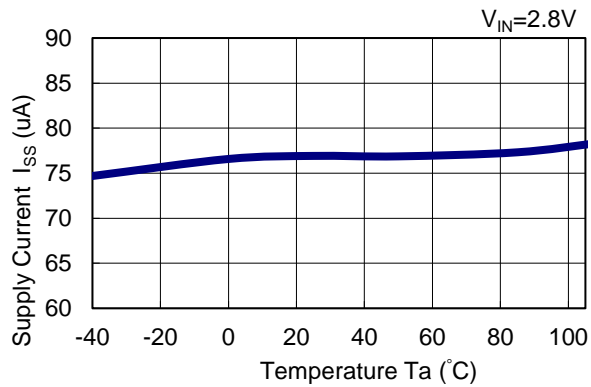
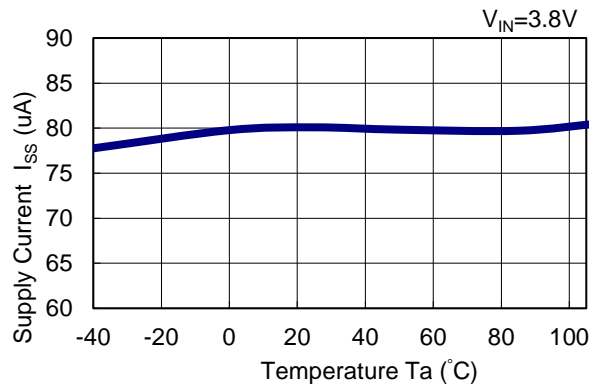
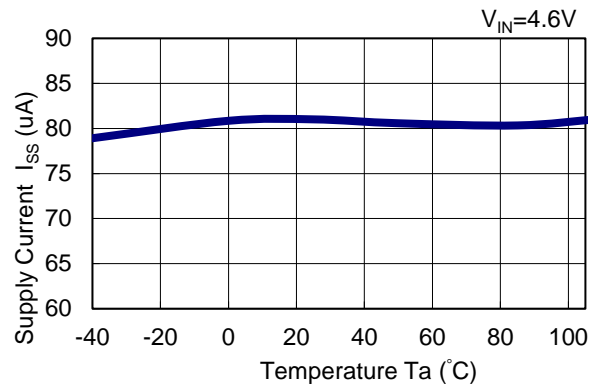
5) Supply Current vs. Temperature (C1 = Ceramic 1.0 μ F, C2 = Ceramic 1.0 μ F, I_{OUT} = 0 mA)**RP111x071x****RP111x171x****RP111x181x****RP111x281x****RP111x361x**

6) Dropout Voltage vs. Output Current (C1 = Ceramic 1.0 μ F, C2 = Ceramic 1.0 μ F)

RP111x071x

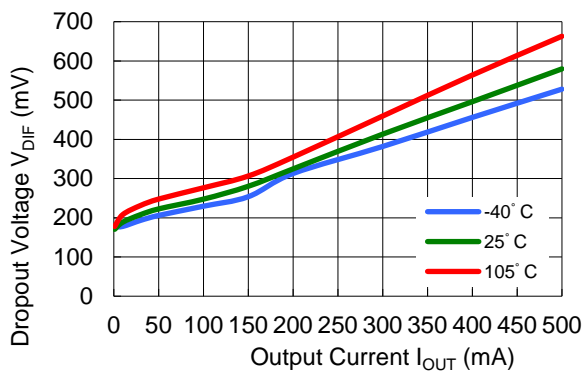

RP111x171x

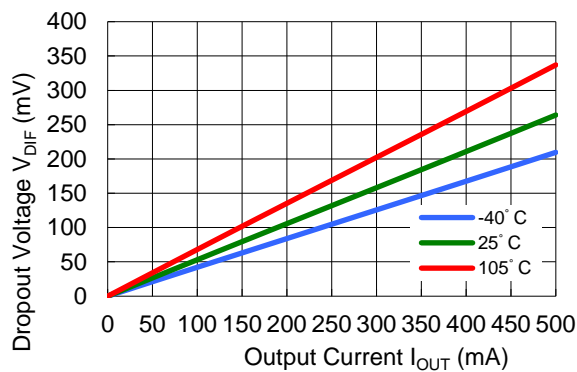

RP111x181x

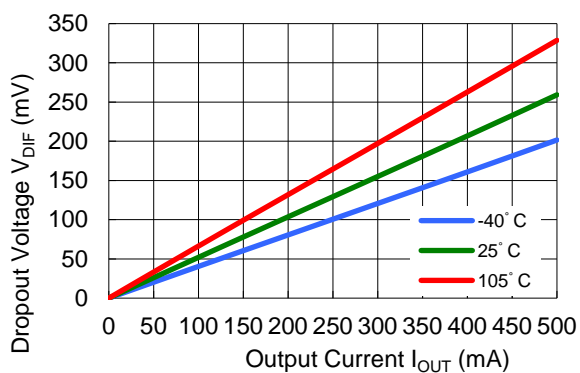

RP111x281x

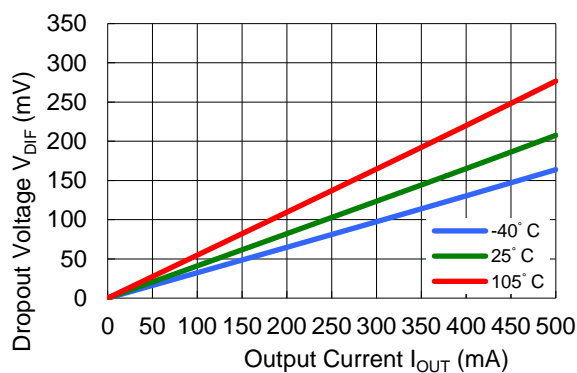

RP111x361x

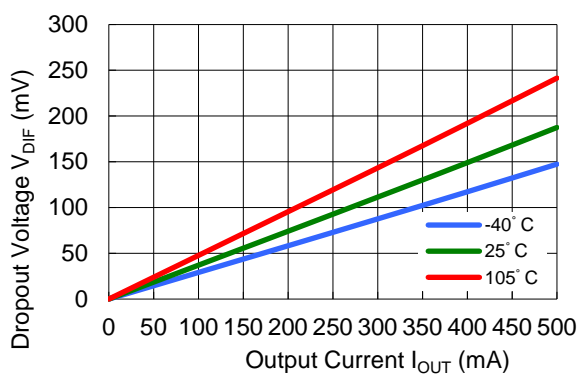

RP111x

NO.EC-241-200403

7) Dropout Voltage vs. Set Output Voltage (C1 = Ceramic 1.0 μ F, C2 = Ceramic 1.0 μ F, Ta = 25°C)

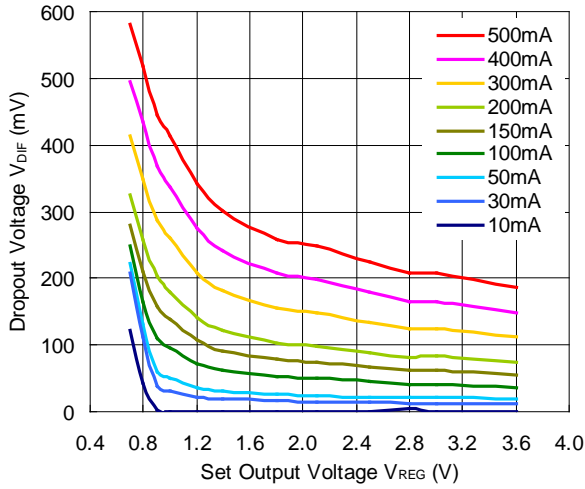

8) Dropout Voltage vs. Temperature (C1 = Ceramic 1.0 μ F, C2 = Ceramic 1.0 μ F)

RP111x071x

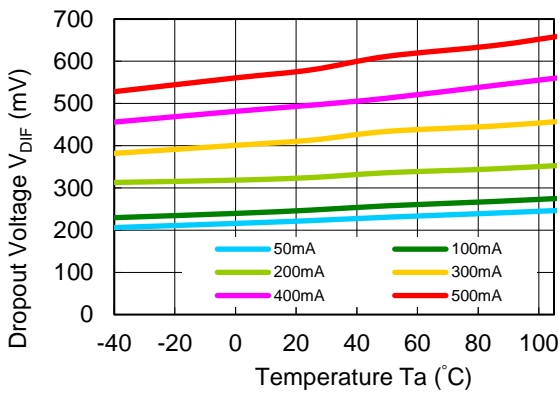

RP111x171x

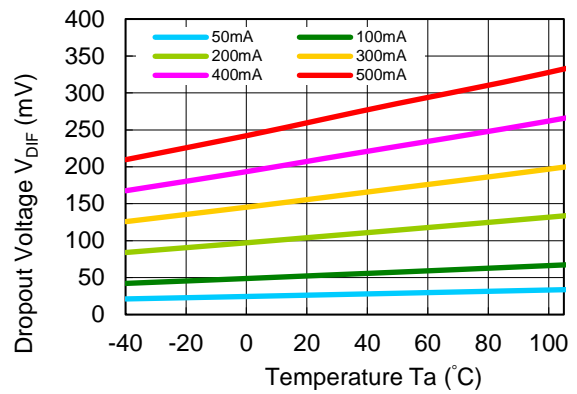

RP111x181x

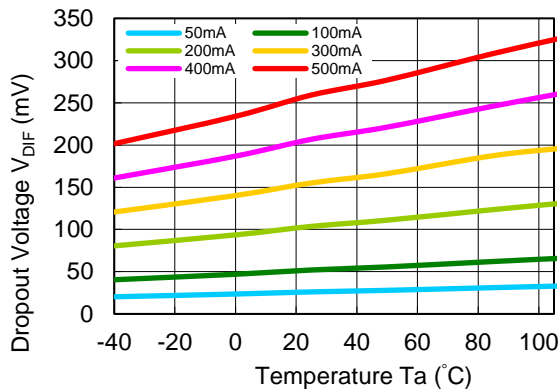

RP111x281x

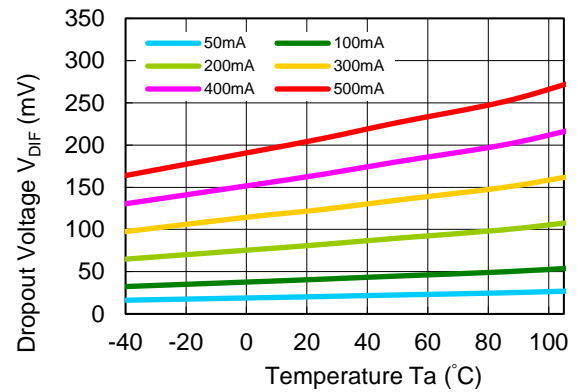

RP111x361x

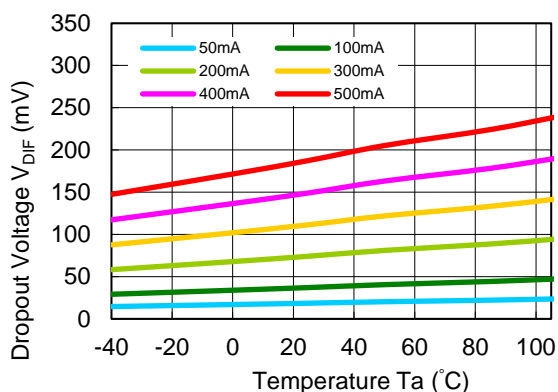

9) Ripple Rejection vs. Input Voltage (C1 = none, C2 = Ceramic 1.0 μF, Ripple = 0.2 V p-p, Ta = 25°C)

RP111x071x

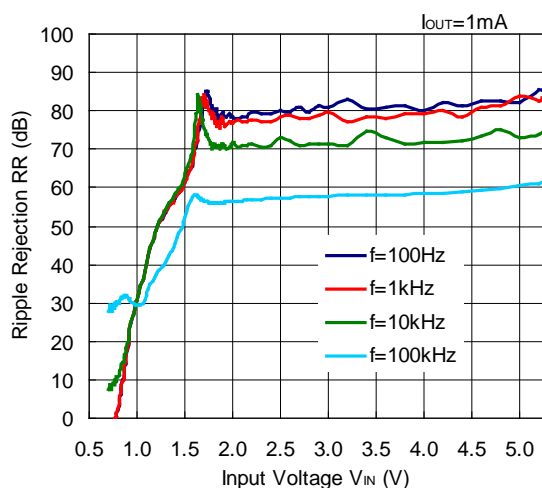

RP111x071x

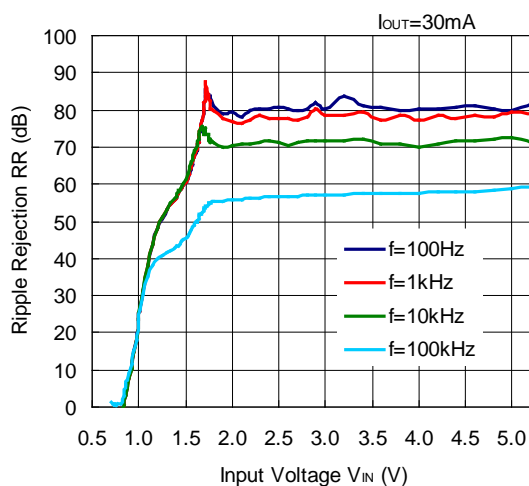

RP111x171x

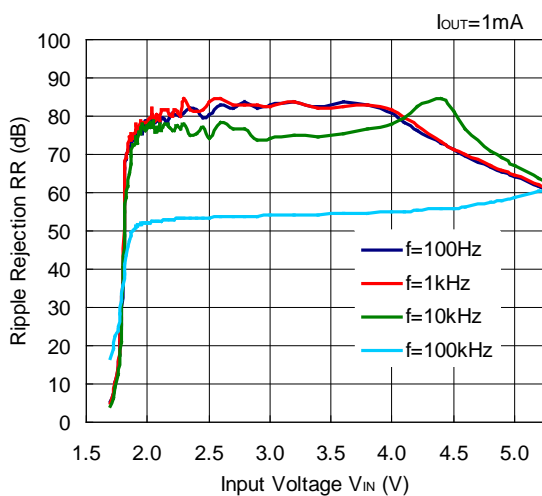

RP111x171x

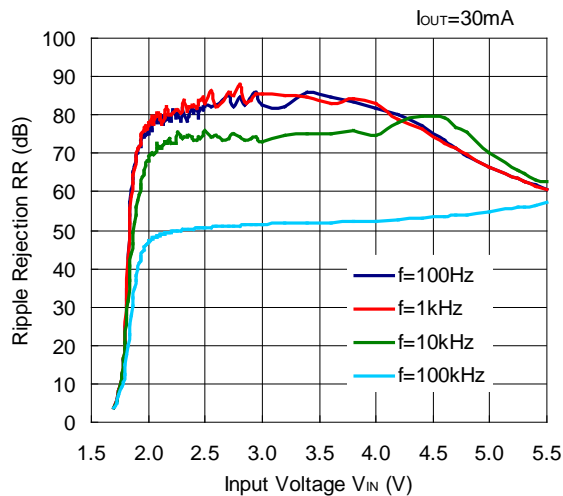

RP111x181x

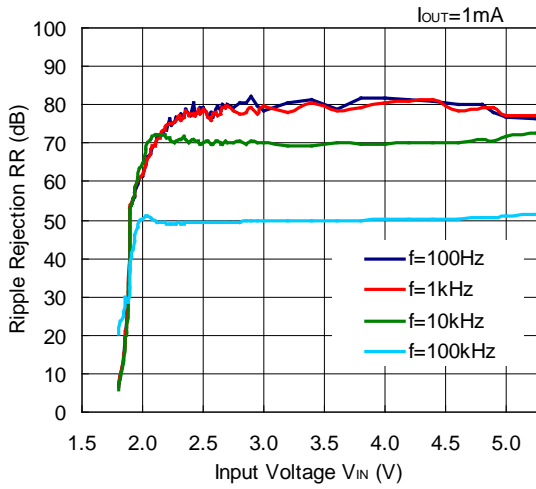

RP111x181x

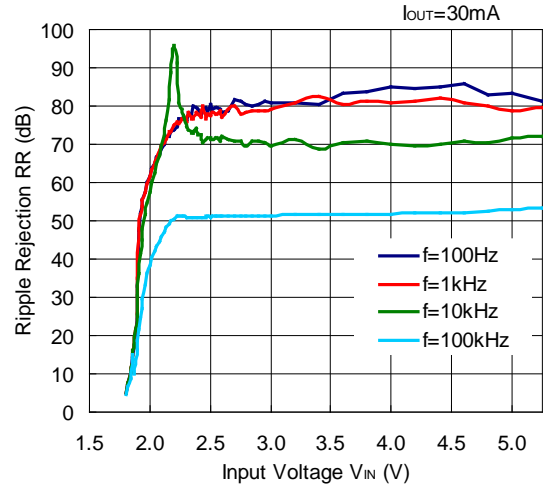

RP111x281x

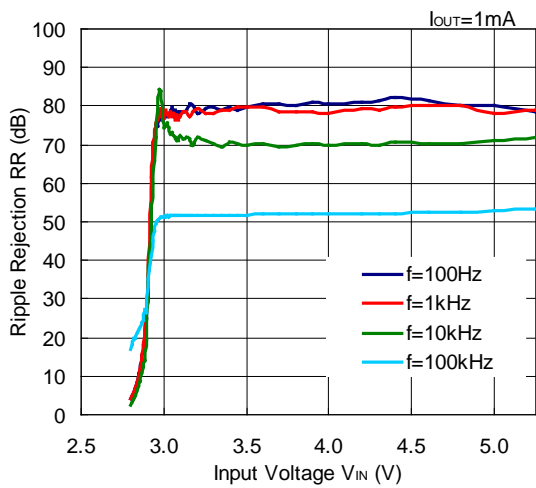

RP111x281x

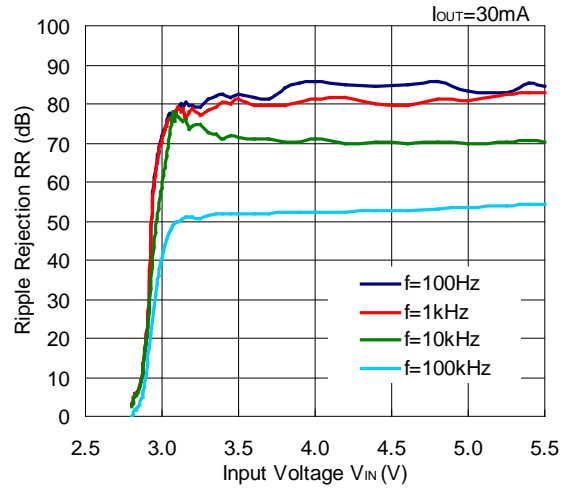

RP111x361x

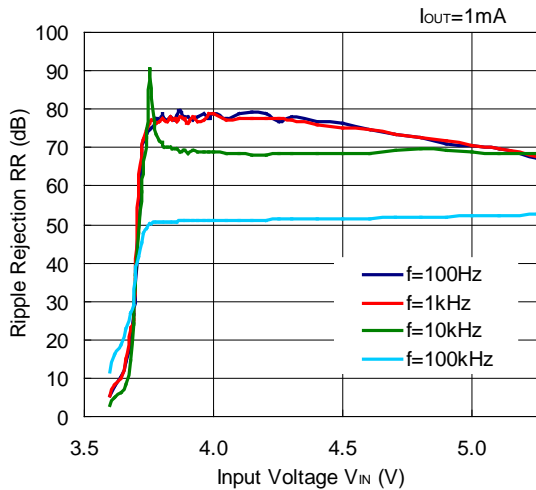

RP111x361x

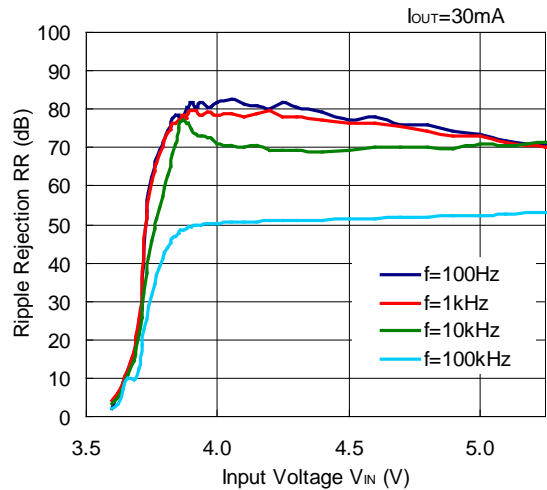

10) Ripple Rejection vs. Frequency (C1 = none, C2 = Ceramic 1.0 μ F, Ripple = 0.2 Vp-p, Ta = 25°C)

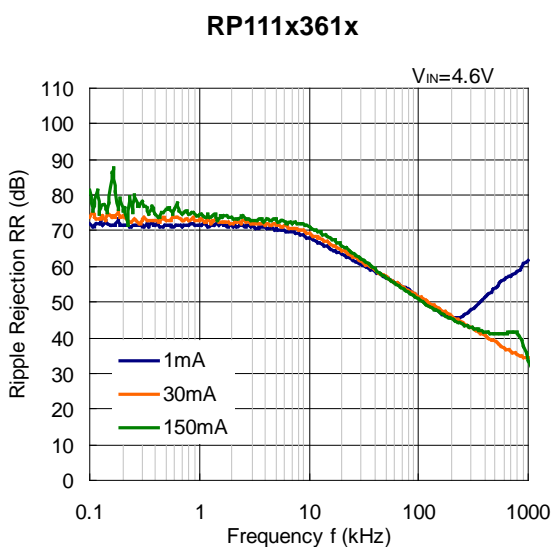
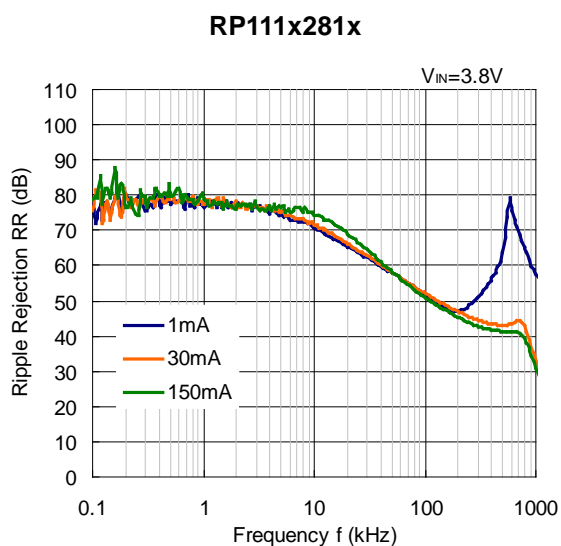
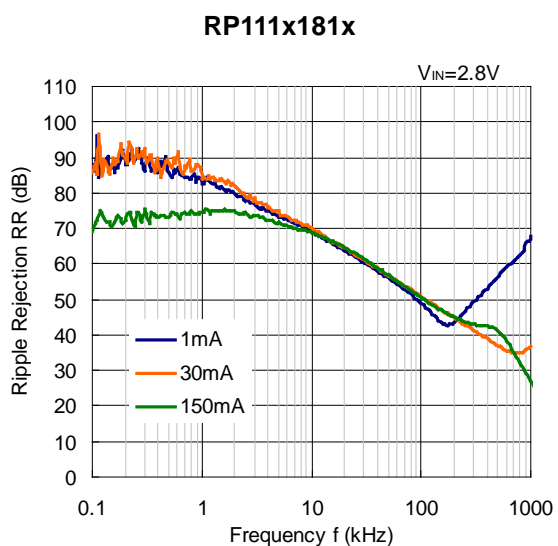
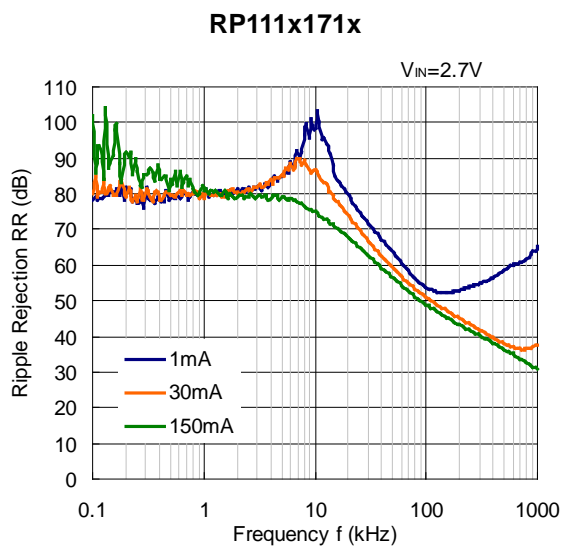
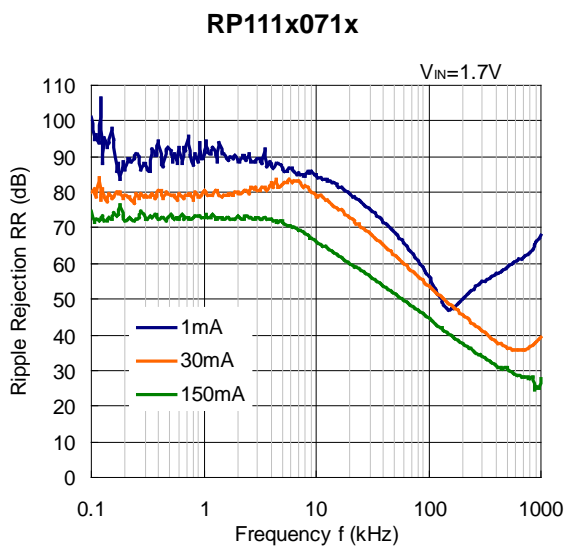

RP111x

NO.EC-241-200403

11) Input Transient Response (C1= none, C2 = Ceramic 1.0 μ F, I_{OUT} = 30 mA, tr = tf = 5 μ s, Ta = 25°C)

RP111x071x

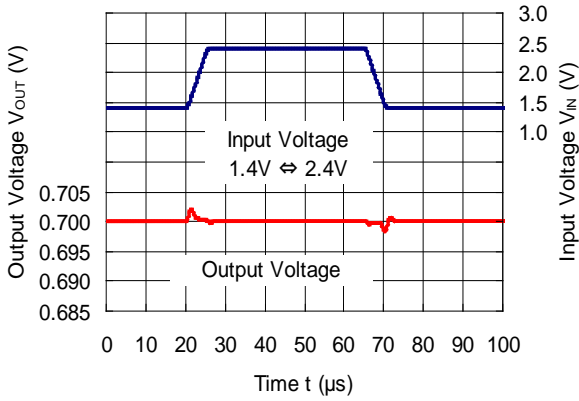

RP111x171x

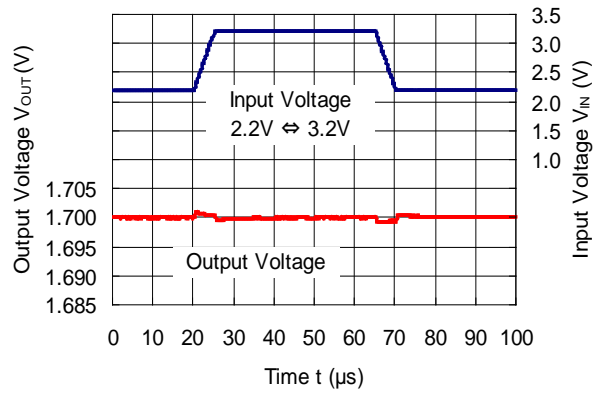

RP111x181x

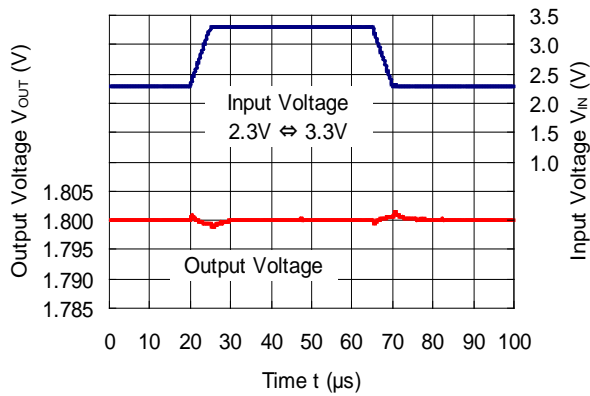

RP111x281x

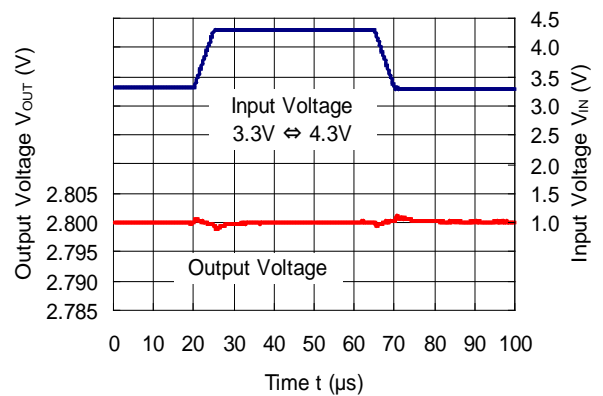

RP111x361x

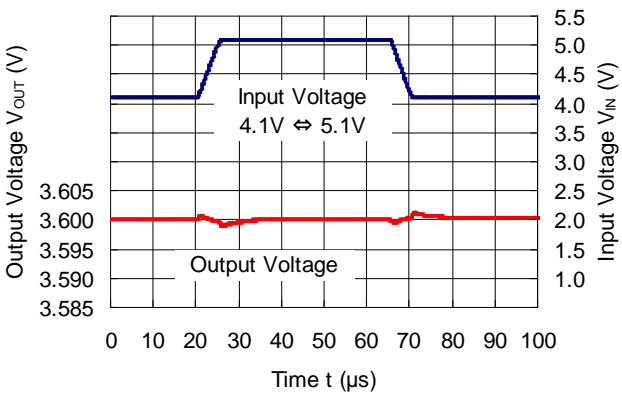

12) Load Transient Response (C1 = Ceramic 1.0 μ F, C2 = Ceramic 1.0 μ F, Ta = 25°C)

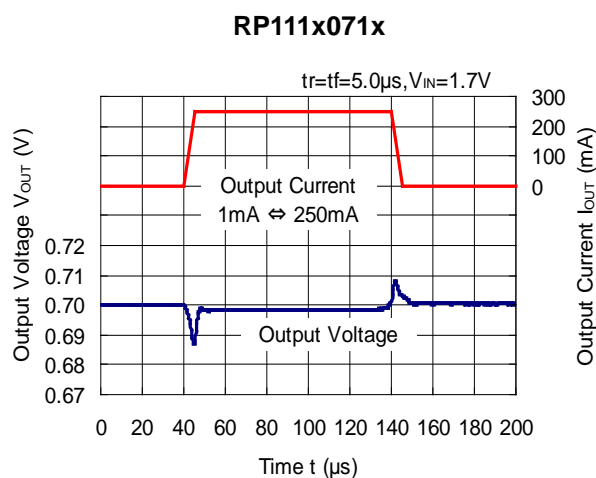
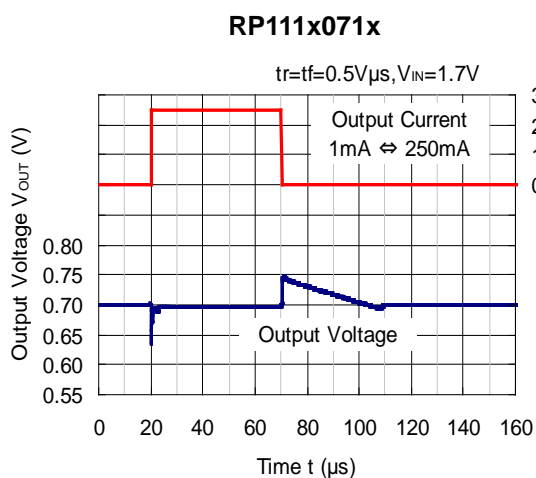
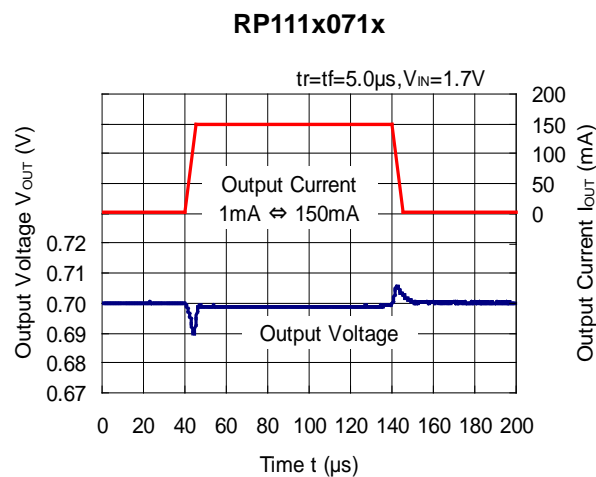
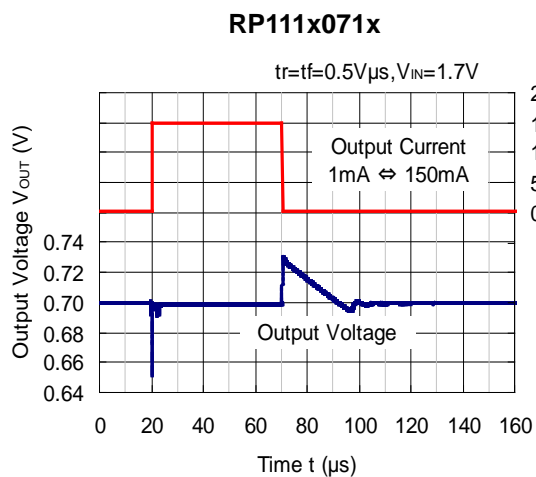
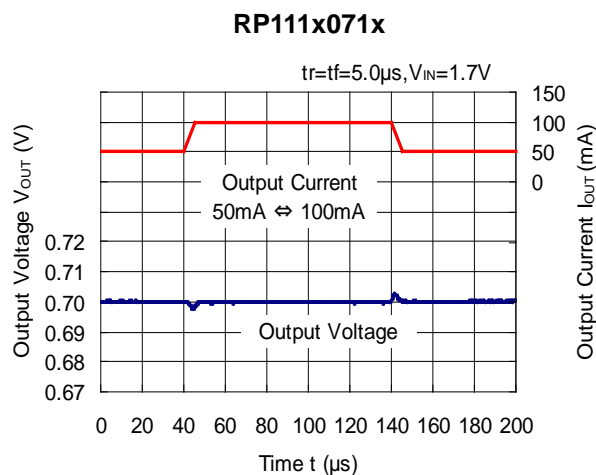
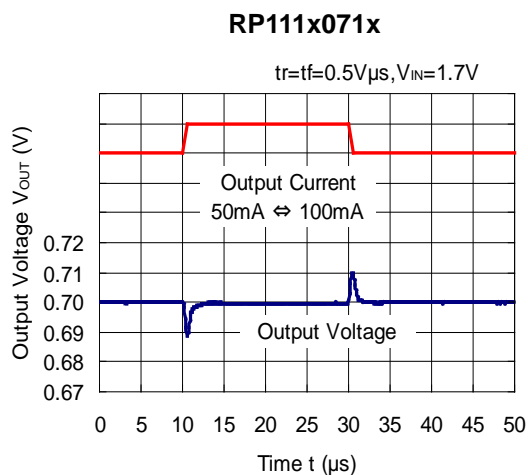

RP111x171x

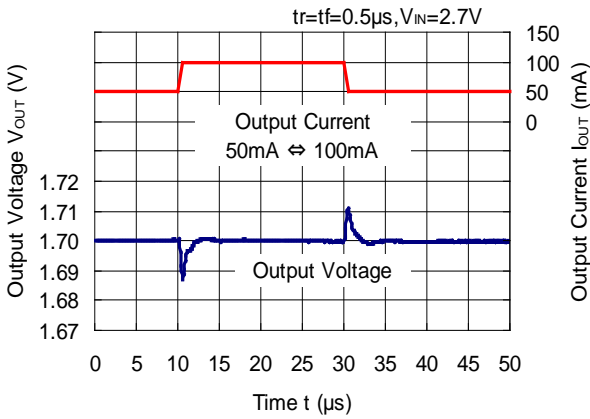

RP111x171x

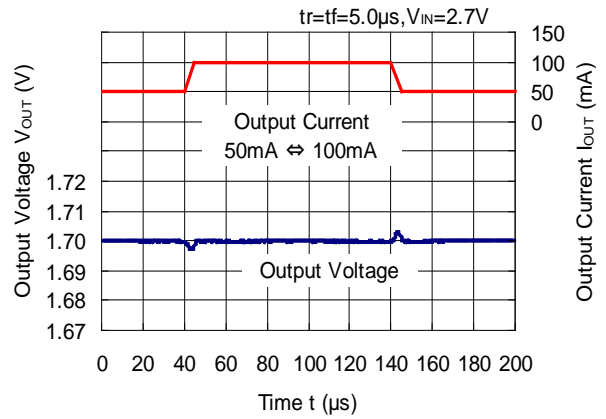

RP111x171x

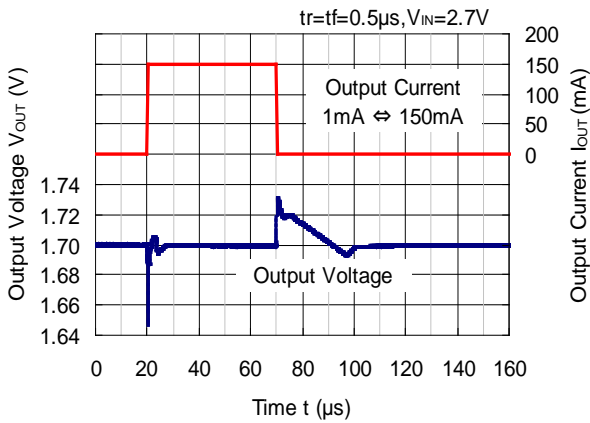

RP111x171x

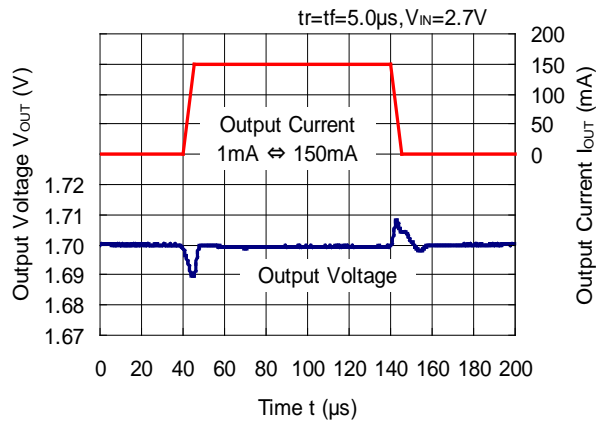

RP111x171x

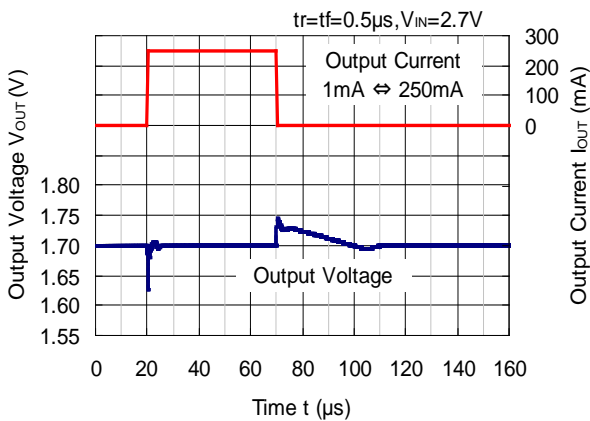

RP111x171x

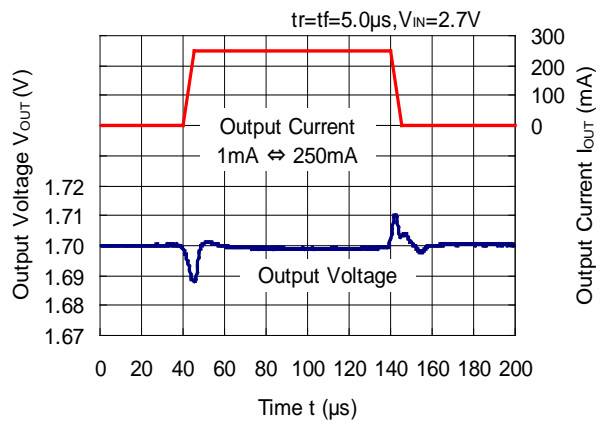

RP111x181x

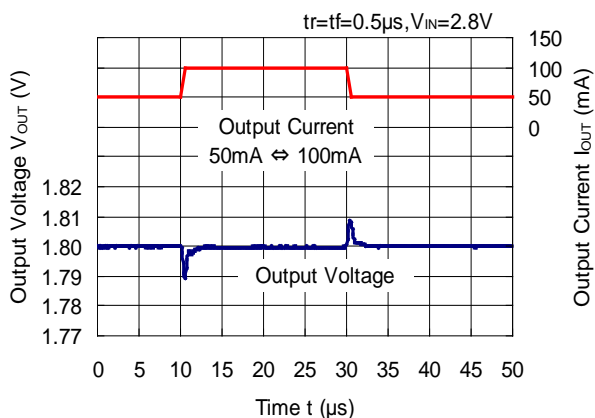

RP111x181x

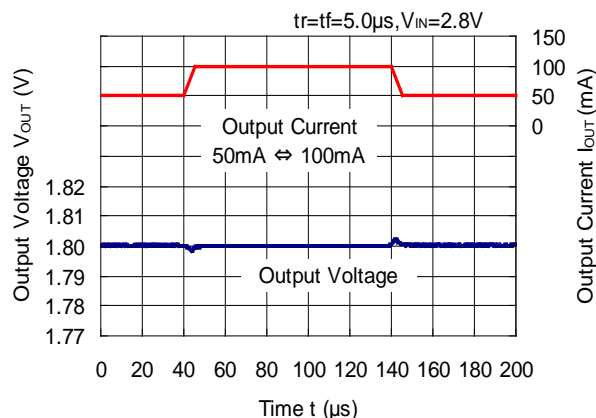

RP111x181x

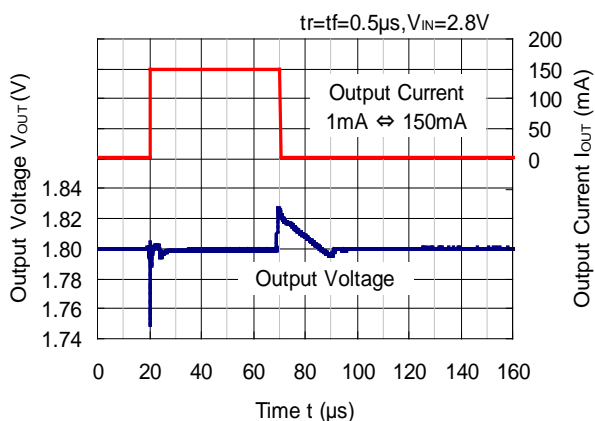

RP111x181x

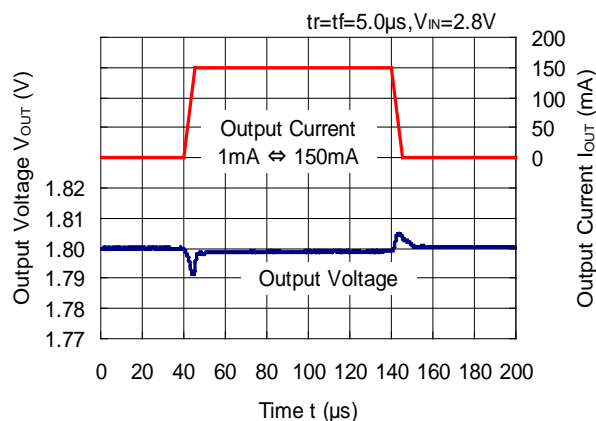

RP111x181x

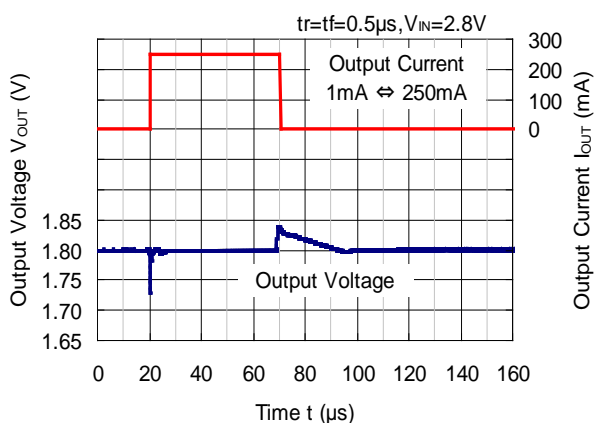

RP111x181x

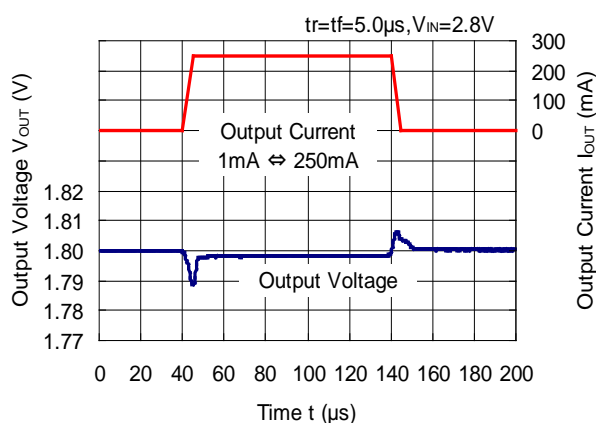

RP111x281x

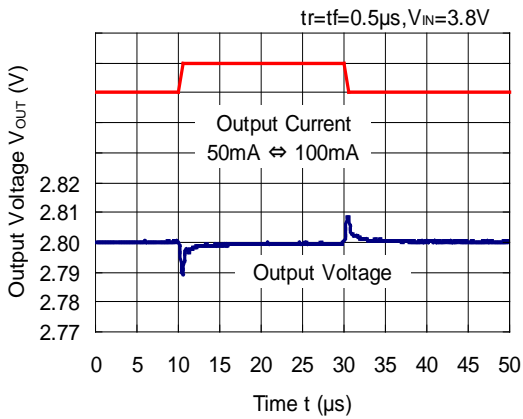

RP111x281x

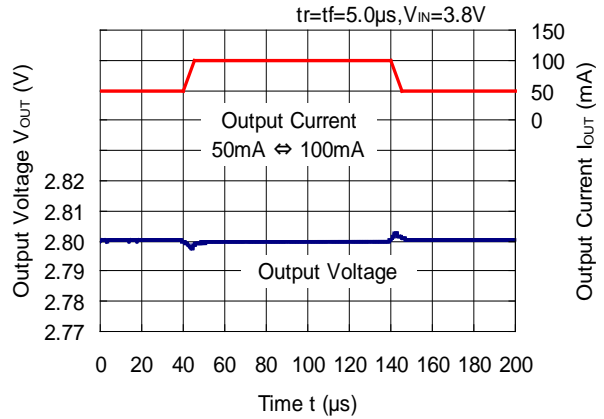

RP111x281x

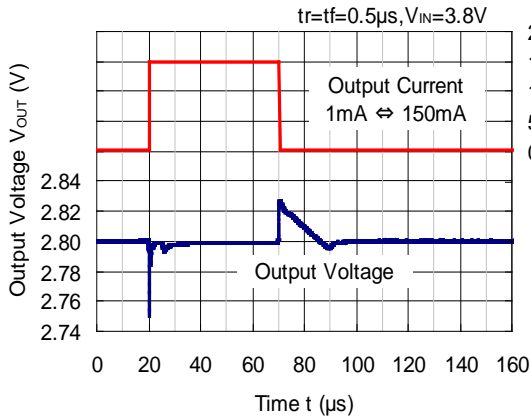

RP111x281x

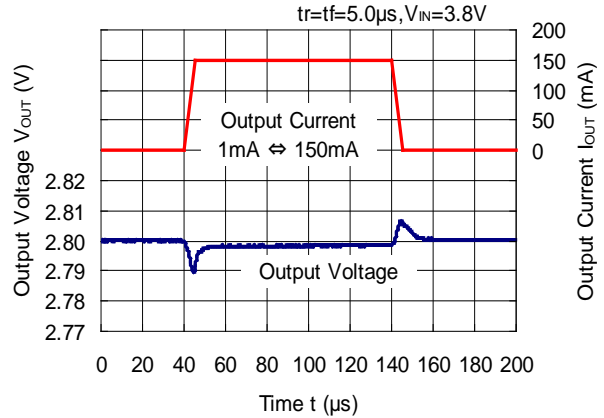

RP111x281x

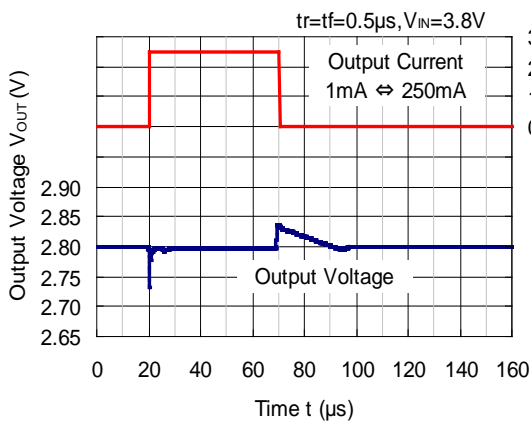

RP111x281x

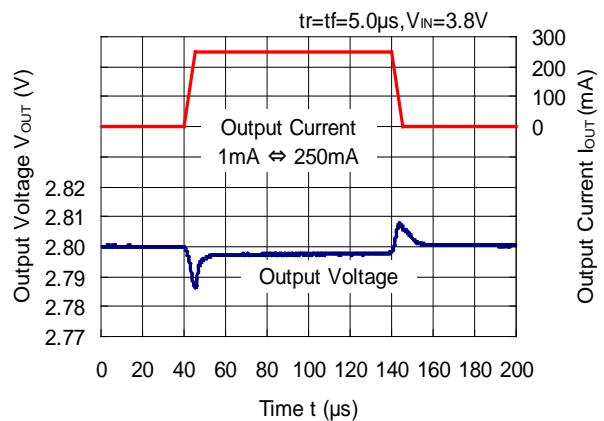

RP111x361x

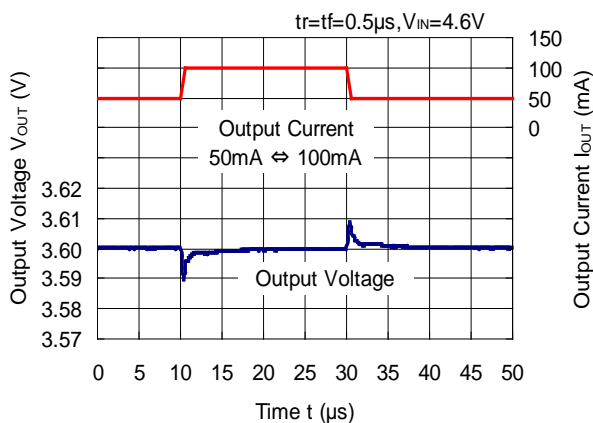

RP111x361x

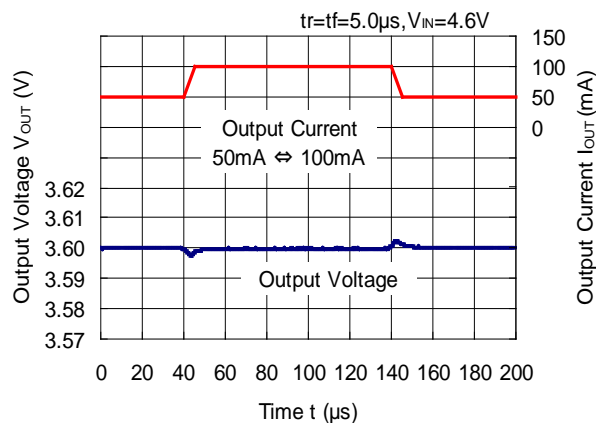

RP111x361x

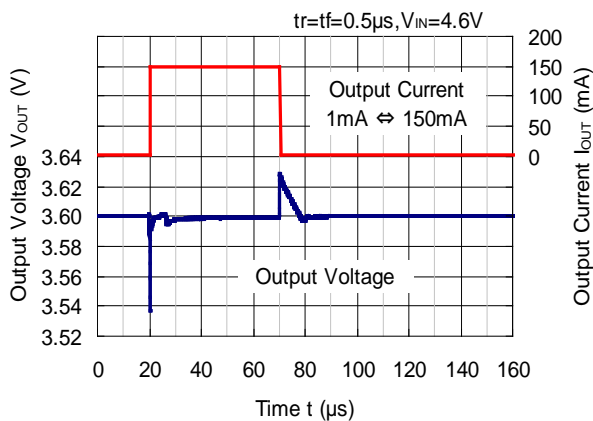

RP111x361x

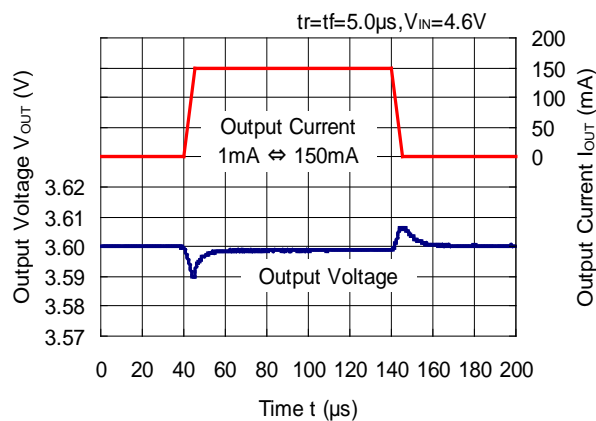

RP111x361x

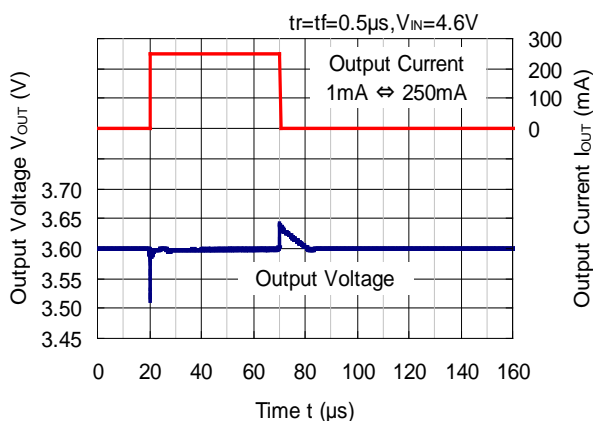

RP111x361x

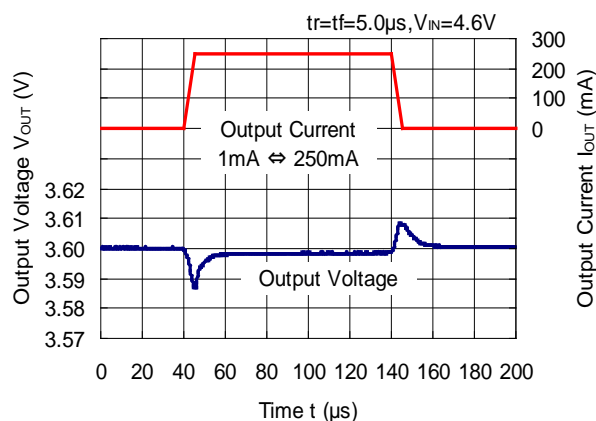

13) Turn on Speed with CE pin (C1 = Ceramic 1.0 μ F, C2 = Ceramic 1.0 μ F, Ta = 25°C)

RP111x071x

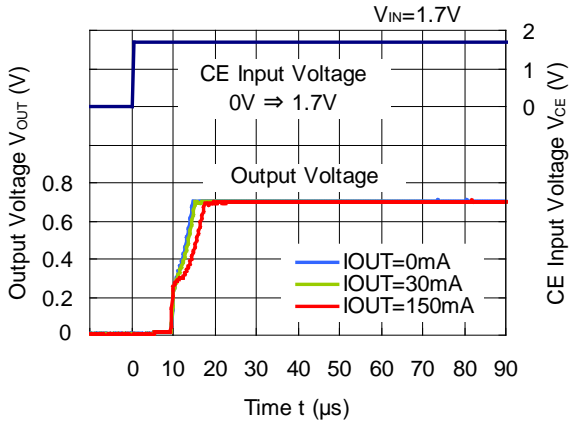

RP111x171x

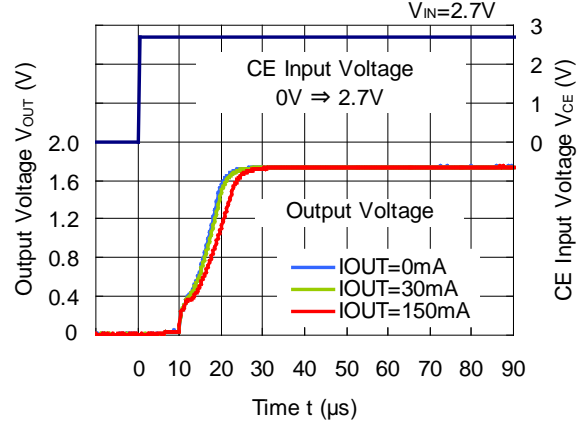

RP111x181x

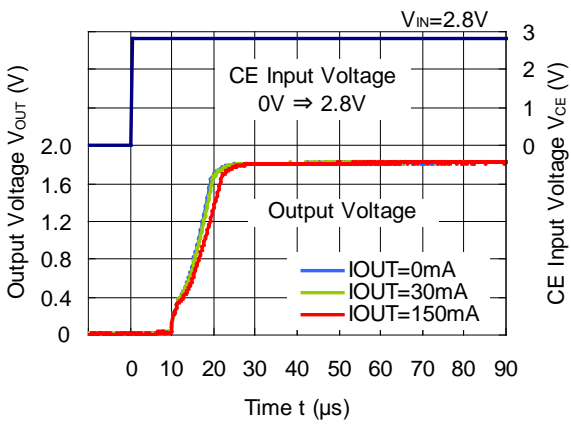

RP111x281x

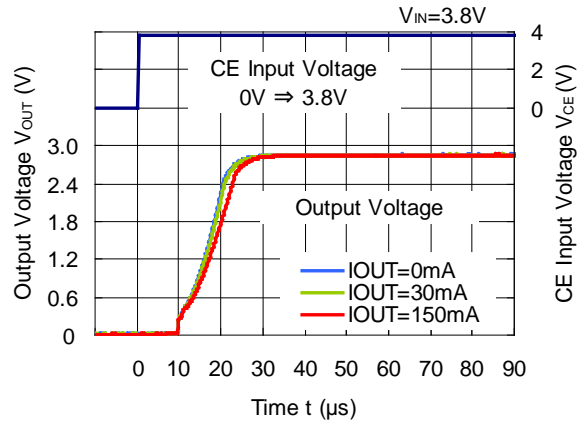

RP111x361

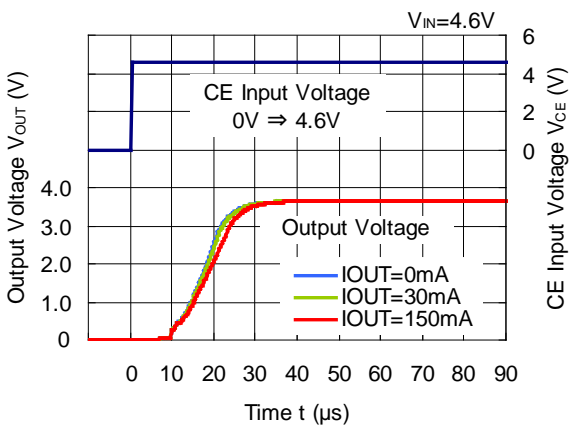

14) Turn off Speed with CE pin (C1 = Ceramic 1.0 μ F, C2 = Ceramic 1.0 μ F, Ta = 25°C)

RP111x071D

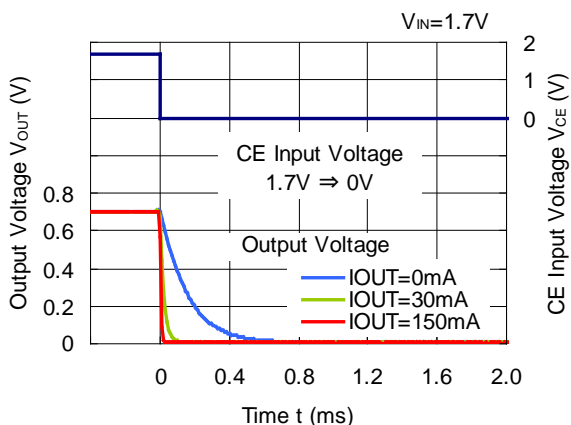

RP111x171D

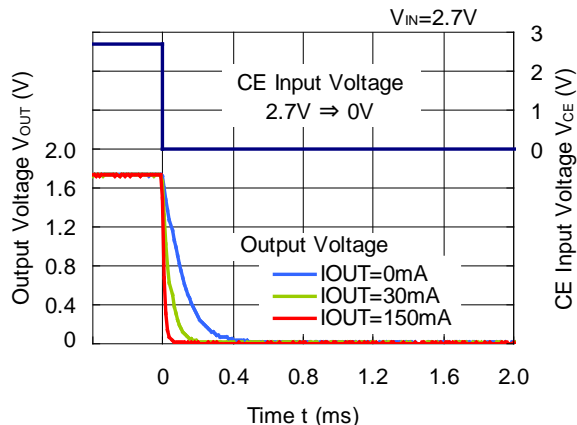

RP111x181D

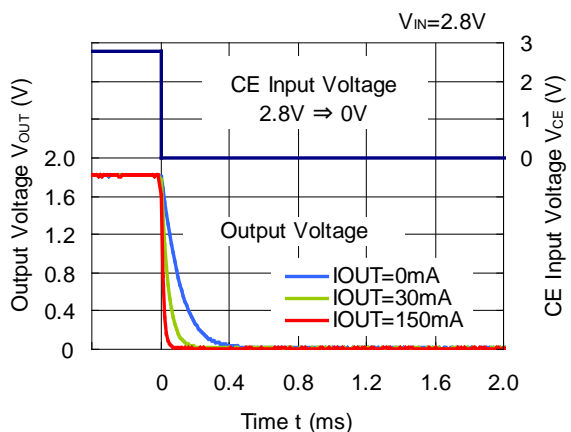

RP111x281D

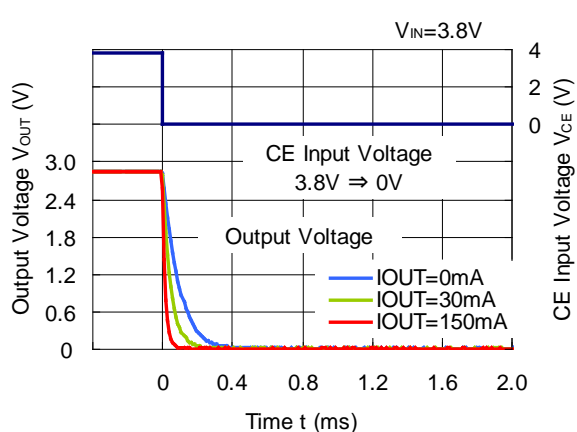

RP111x361D

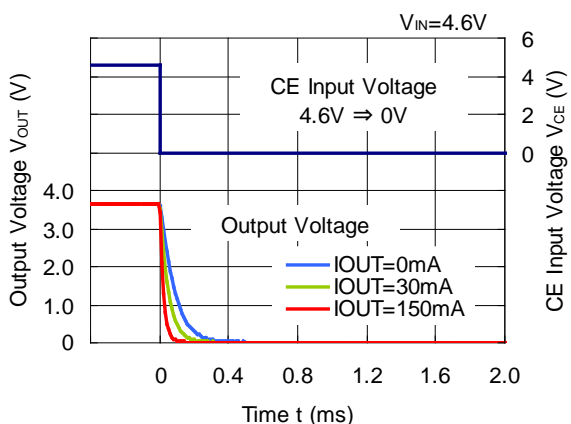

15) Inrush Current (C1 = Ceramic 1.0 μ F, I_{OUT} = 0 mA, Ta = 25°C)

RP111x071x

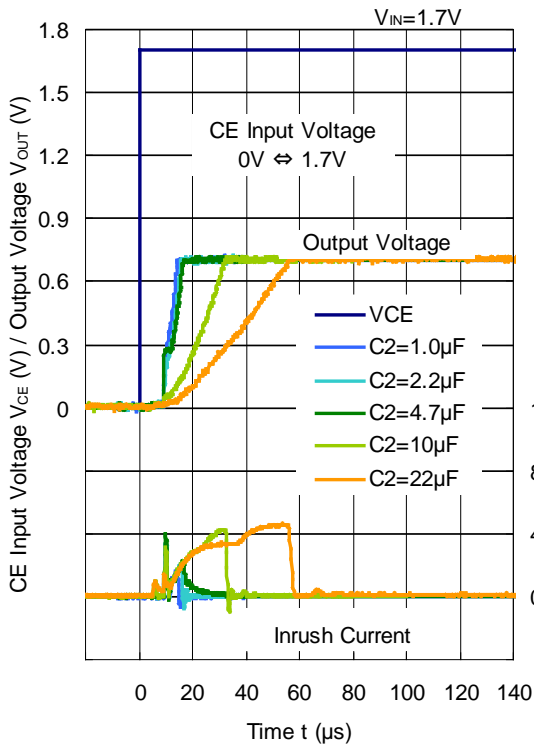

RP111x071x

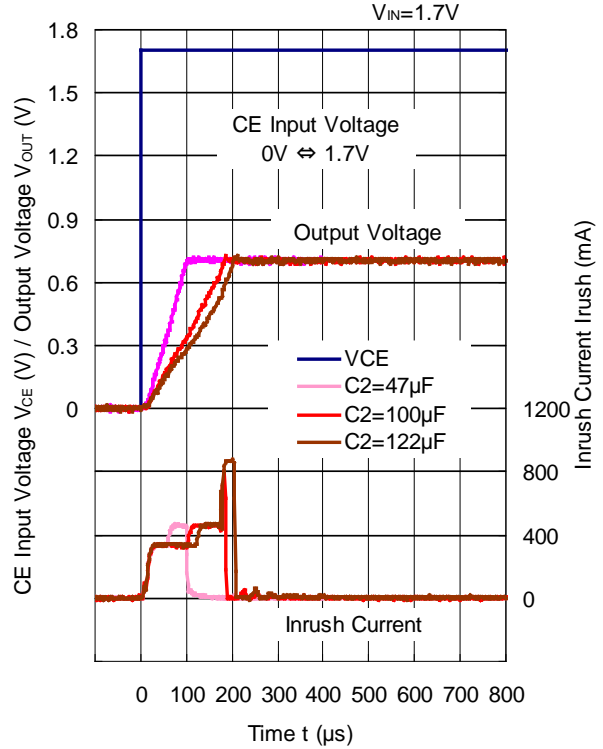

RP111x171x

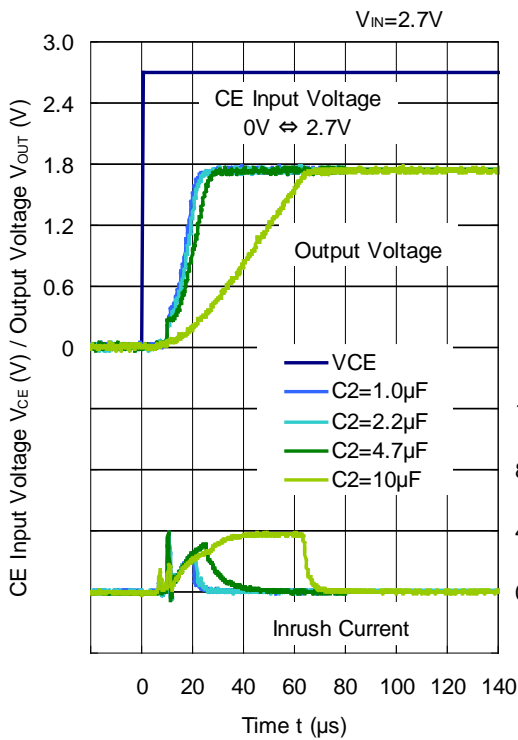

RP111x171x

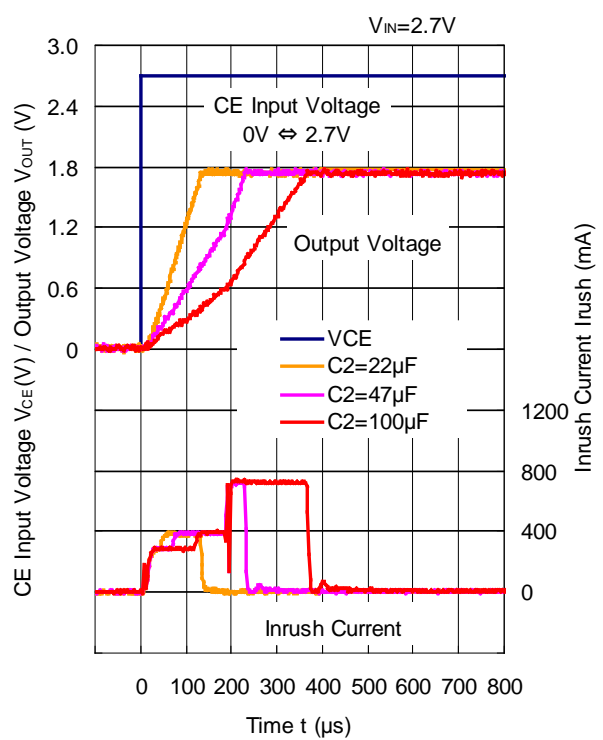

RP111x181x

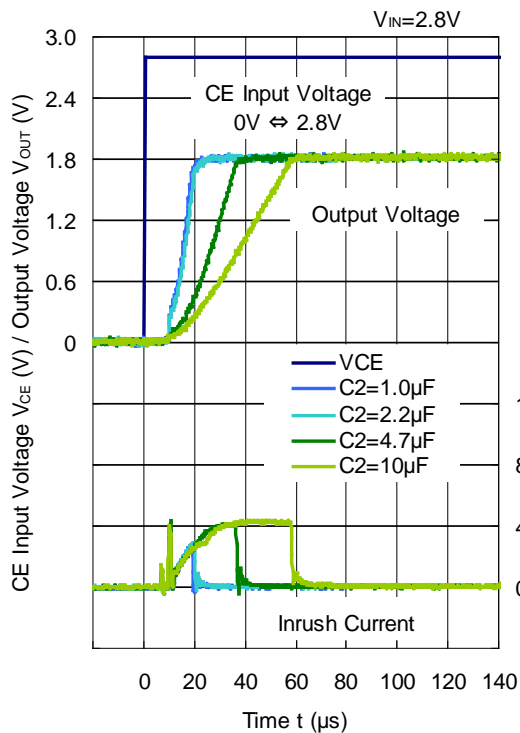

RP111x181x

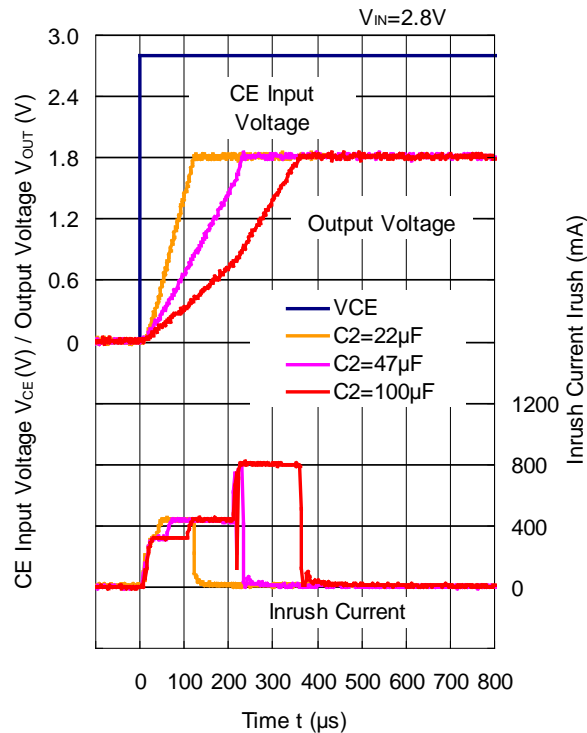

RP111x281x

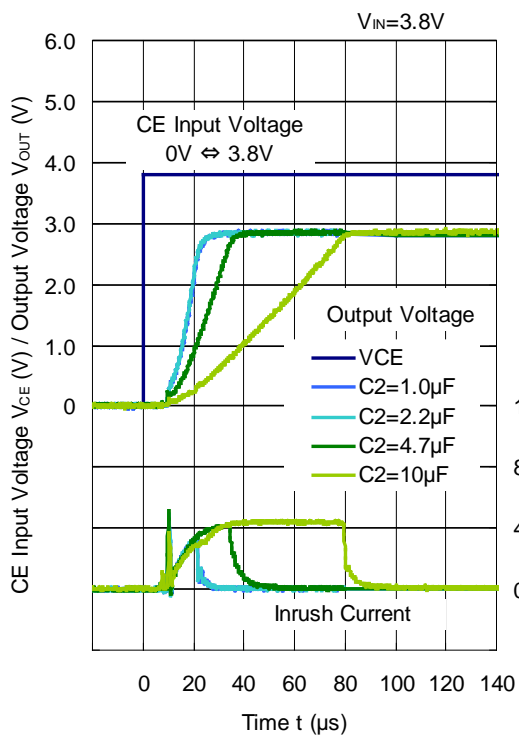

RP111x281x

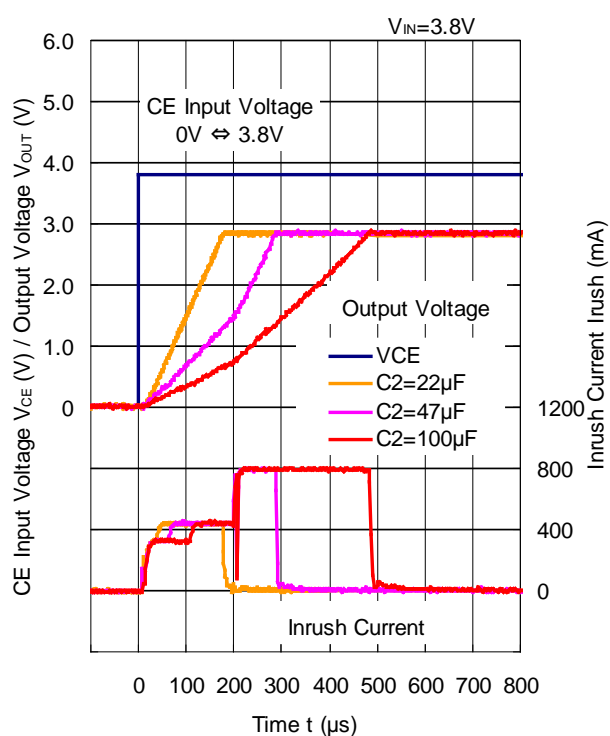

RP111x361x

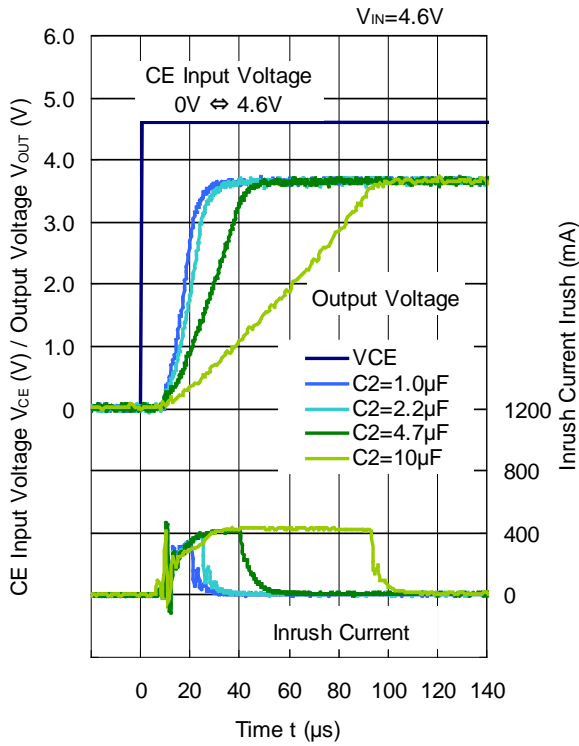

RP111x361x

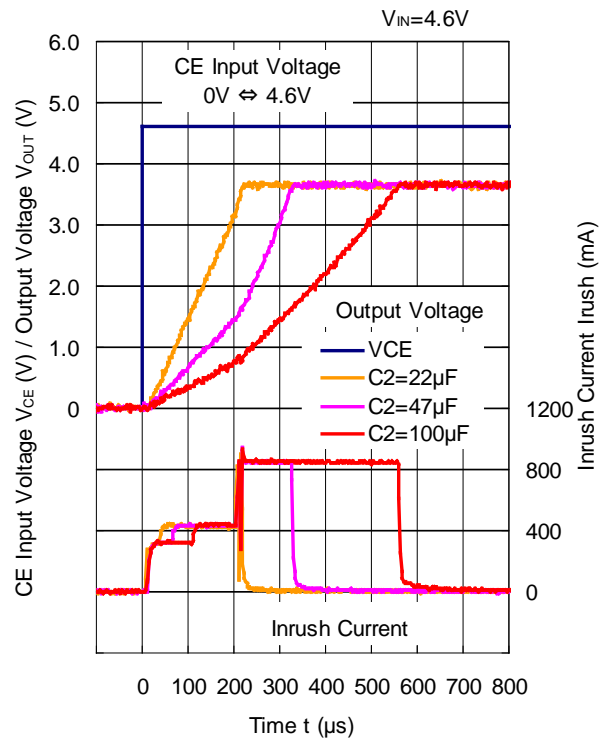

Measurement Components of Typical Characteristics

Symbol	Capacitance	Test item	Manufacture	Parts number
C1	1.0 μ F	All	Murata	GRM155B31A105KE15
C2	1.0 μ F	All except Inrush Current	Murata	GRM155B31A105KE15

ESR vs. Output Current

When using these ICs, consider the following points: The relations between I_{OUT} (Output Current) and ESR of an output capacitor are shown below. The conditions when the white noise level is under $40 \mu\text{V}$ (Avg.) are marked as the hatched area in the graph.

Measurement Conditions

Frequency Band : 10 Hz to 2 MHz

Temperature : -40°C to 85°C

C1, C2 : $1.0 \mu\text{F}$ or more

RP111x071x

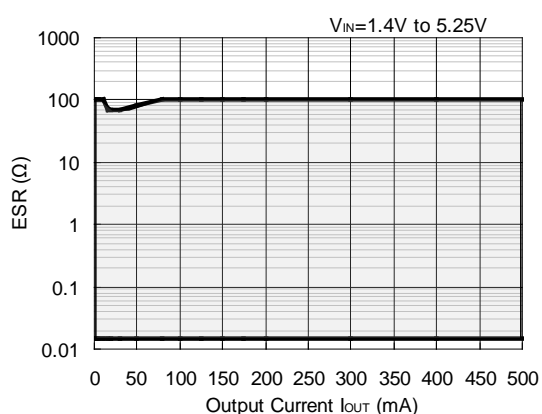

RP111x171x

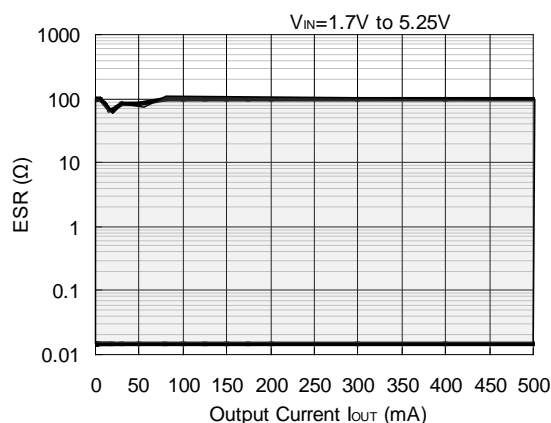

RP111x181x

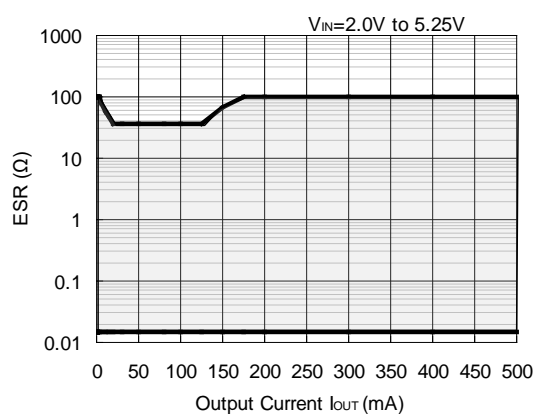

RP111x281x

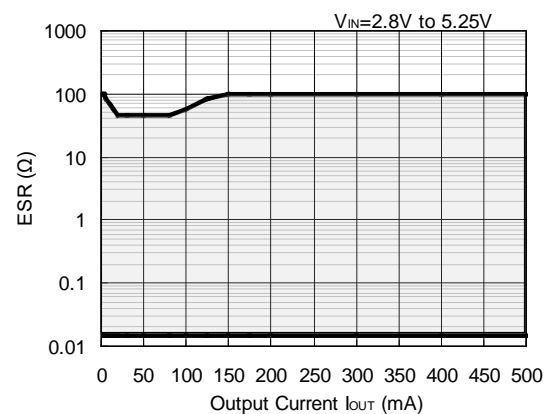

RP111x361x

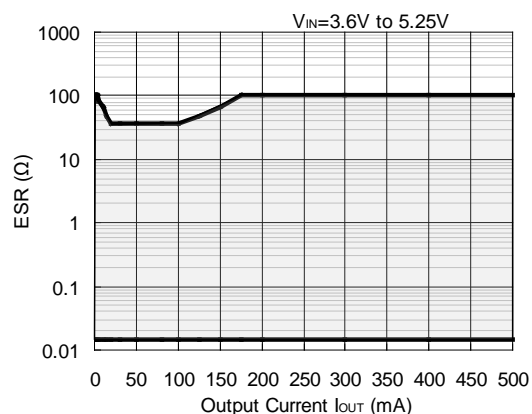



1. The products and the product specifications described in this document are subject to change or discontinuation of production without notice for reasons such as improvement. Therefore, before deciding to use the products, please refer to Ricoh sales representatives for the latest information thereon.
2. The materials in this document may not be copied or otherwise reproduced in whole or in part without prior written consent of Ricoh.
3. Please be sure to take any necessary formalities under relevant laws or regulations before exporting or otherwise taking out of your country the products or the technical information described herein.
4. The technical information described in this document shows typical characteristics of and example application circuits for the products. The release of such information is not to be construed as a warranty of or a grant of license under Ricoh's or any third party's intellectual property rights or any other rights.
5. The products in this document are designed for automotive applications. However, when using the products for automotive applications, please make sure to contact Ricoh sales representative in advance due to confirming the quality level.
6. We are making our continuous effort to improve the quality and reliability of our products, but semiconductor products are likely to fail with certain probability. In order to prevent any injury to persons or damages to property resulting from such failure, customers should be careful enough to incorporate safety measures in their design, such as redundancy feature, fire containment feature and fail-safe feature. We do not assume any liability or responsibility for any loss or damage arising from misuse or inappropriate use of the products.
7. Anti-radiation design is not implemented in the products described in this document.
8. The X-ray exposure can influence functions and characteristics of the products. Confirm the product functions and characteristics in the evaluation stage.
9. WLCSP products should be used in light shielded environments. The light exposure can influence functions and characteristics of the products under operation or storage.
10. There can be variation in the marking when different AOI (Automated Optical Inspection) equipment is used.
In the case of recognizing the marking characteristic with AOI, please contact Ricoh sales or our distributor before attempting to use AOI.
11. Please contact Ricoh sales representatives should you have any questions or comments concerning the products or the technical information.



Ricoh is committed to reducing the environmental loading materials in electrical devices with a view to contributing to the protection of human health and the environment.

Ricoh has been providing RoHS compliant products since April 1, 2006 and Halogen-free products since April 1, 2012.

RICOH RICOH ELECTRONIC DEVICES CO., LTD.

Official website

<https://www.n-redc.co.jp/en/>

Contact us

<https://www.n-redc.co.jp/en/buy/>

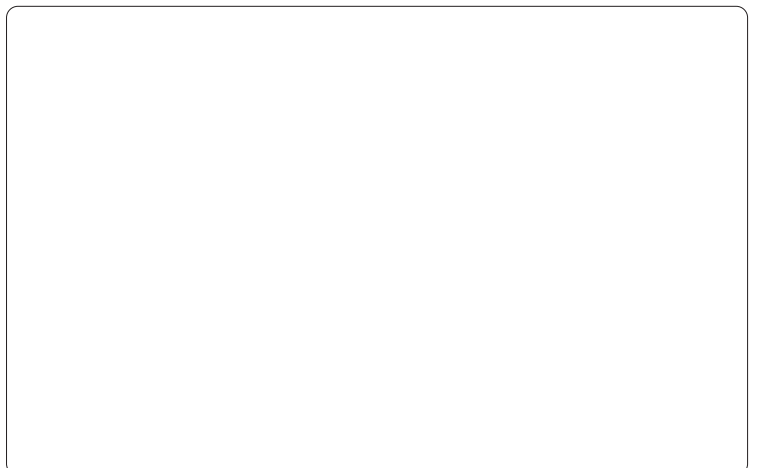

Mouser Electronics

Authorized Distributor

Click to View Pricing, Inventory, Delivery & Lifecycle Information:

Ricoh Electronics:

[RP111H001B-T1-JE](#) [RP111H001D-T1-JE](#) [RP111H121D-T1-JE](#) [RP111H251D-T1-JE](#) [RP111H331B-T1-JE](#)
[RP111H331D-T1-JE](#) [RP111S121D-E2-JE](#) [RP111S181D-E2-JE](#) [RP111S251D-E2-JE](#) [RP111S281D-E2-JE](#)
[RP111S331B-E2-JE](#) [RP111S331D-E2-JE](#) [RP111N001D-TR-JE](#) [RP111N101D-TR-JE](#) [RP111N121D-TR-JE](#)
[RP111N151D-TR-JE](#) [RP111N281D-TR-JE](#) [RP111S001D-E2-JE](#)