

# Harsh Media Pressure Sensor NPR-101



NovaSensor's NPR-101 pressure sensor is a silicon-based MEMS device using "Backside Absolute Pressure" technology designed for harsh media exposure, which eliminates the direct contact of the sensing circuitry with the applied media. The device is coupled with an ASIC to provide a ratiometric output proportional to the applied pressure. Integrated diagnostics included.

## Applications

- Transmission fluid pressure sensing
- Oil pressure sensing
- Fuel pressure sensing

## Features

- Harsh media compatibility
- High level output
- Small package



# Harsh Media Pressure Sensor Specifications

## NPR-101

Operating Pressure Range	300 PSIA full scale pressure (20.68 BarA)
<b>Performance</b>	
Total Error band	+/-2.0% FP (-20C to 100C) +/-3.0% FP (100C to 140C)
<b>Electrical</b>	
Supply Voltage (Vcc)	4.5 to 5.5 VDC (6.5 VDC MAX)
Supply Current	3 ma
Output Range	10% to 90% of Vcc
Over-Voltage Protection	6.5 VDC MAX
Reverse Voltage Protection	None
<b>Durability</b>	
Cycle Life	1 million cycles
Proof Pressure	1.5 times rated pressure
Burst Pressure	2.5 times rated pressure

## Output Curve : NPR-101

Other transfer functions available on request

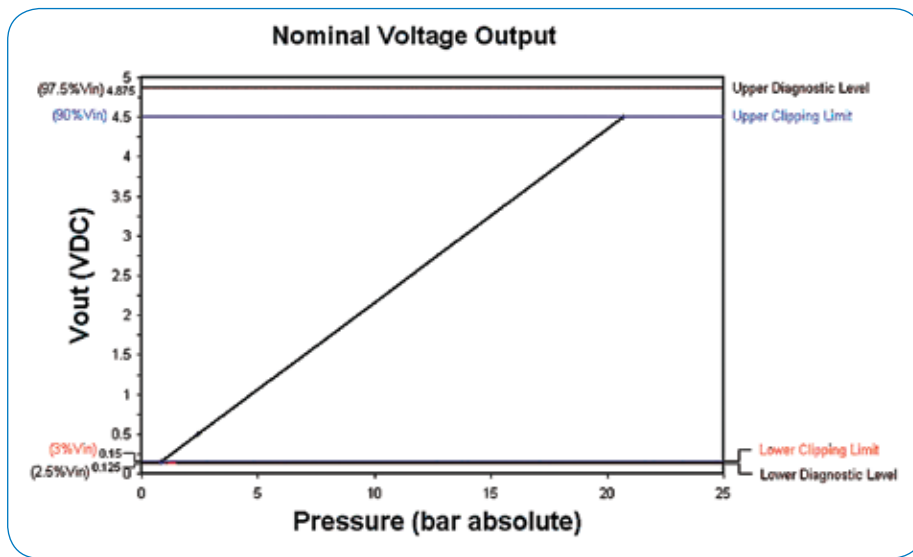

## Dimensions

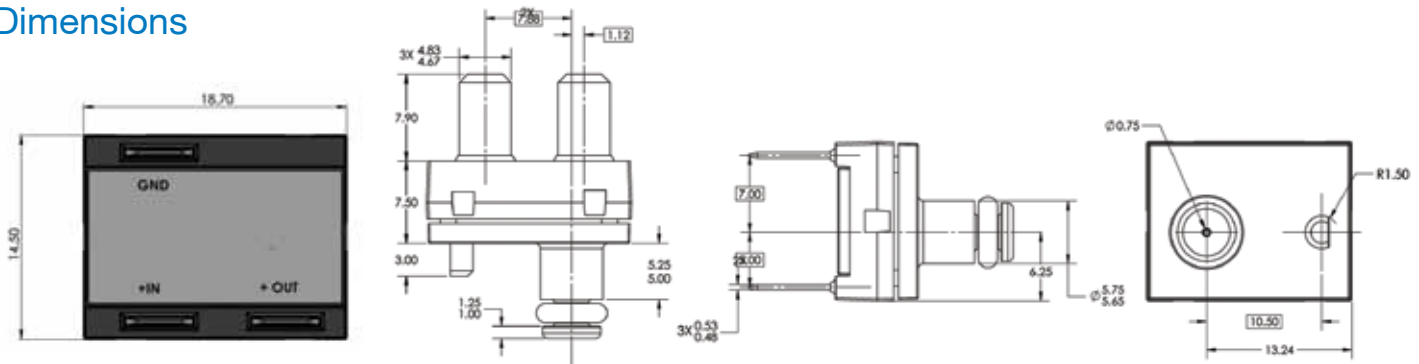

**Amphenol**  
Advanced Sensors

[www.amphenol-sensors.com](http://www.amphenol-sensors.com)

© 2016 Amphenol Corporation. All Rights Reserved. Specifications are subject to change without notice. Other company names and product names used in this document are the registered trademarks or trademarks of their respective owners.

# Mouser Electronics

Authorized Distributor

Click to View Pricing, Inventory, Delivery & Lifecycle Information:

[Amphenol:](#)

[NPR-101](#)