

NOTES:

1. COVER & BASE - STEEL  
 -FINISH - MIL-F-14072 (SIG.-C)  
 -BASIC FINISH#P-211 TYPE EXPOSURE 1  
 -FINAL FINISH PER TT-E-529 ENAMEL  
 SYNTHETIC SEMI-GLOSS BLACK PER -A1
2. GASKET - SYNTHETIC RUBBER
3. TORSION SPRING - STAINLESS STEEL
4. RIVET - STAINLESS STEEL
5. RIVET WASHER - BRASS.
6. ACCESSORY WASHER - STEEL, NICKEL PLATE

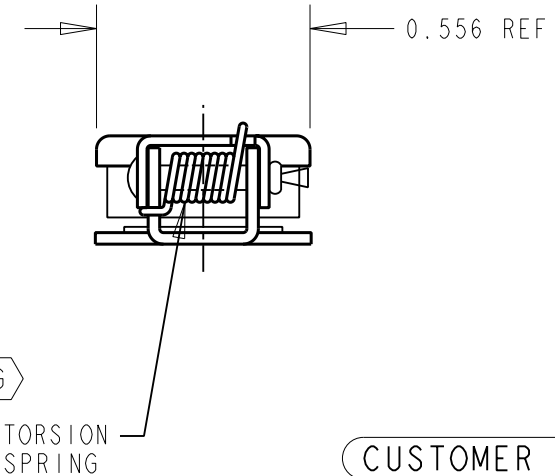
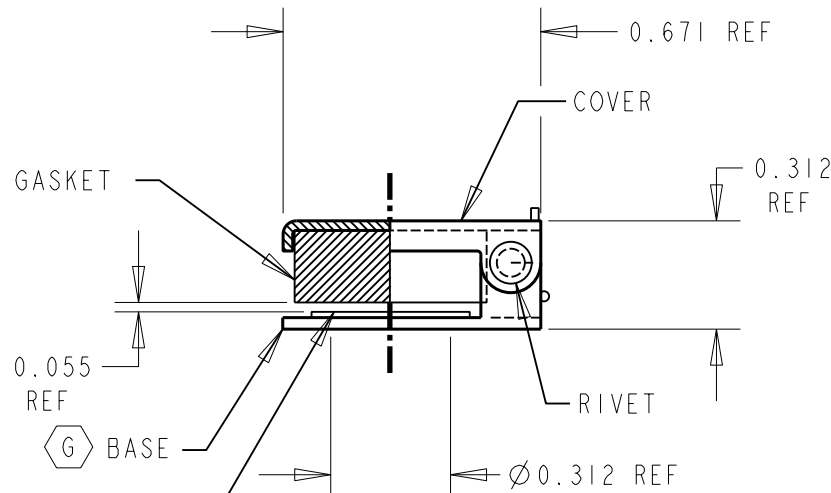

CUSTOMER DRAWING

					★ STAR SYMBOL DENOTES CRITICAL DIMENSION	THIS DRAWING DESCRIBES A DESIGN CONSIDERED PROPRIETARY IN NATURE, DEVELOPED AND MANUFACTURED BY SWITCHCRAFT INC. AND IS RELEASED ON A CONFIDENTIAL BASIS FOR IDENTIFICATION PURPOSES ONLY.					
					UNLESS OTHERWISE SPECIFIED	SIZE	WIDTH	MULT	LBS/M	TEMPER	
					1. ALL DIMENSIONS IN INCHES - TWO PLACE DECIMALS ±0.01 - THREE PLACE DECIMALS ±0.005 - ANGLES ±1° - ALL DIA. CONCENTRIC WITHIN 0.005 T.I.R.	FINISH			MATERIAL		
					2. FEATURES ON THE SAME CENTERLINE MUST BE ALIGNED WITHIN ±0.002	SPEC No.			SPEC No.		
					3. REMOVE ALL BURRS	FIRST USED ON		SCALE			
						2 : 1			<b>Switchcraft®</b>		
G	23140	4-20-00	DA	DK	DATE DRAWN	BY	CHKD	APVD			
F	ECO #22434	10-29-98	RC	JF	3-21-88	EB	JF 8-3-90	DLV 8-3-90	SHEET   OF		
REV	ECO NUMBER	DATE	BY	APVD	NAME			PART No.		REV	
REVISIONS					DO NOT SCALE DRAWING			TIP JAX COVER ASS'Y BLACK		2C1072 G	

# Mouser Electronics

Authorized Distributor

Click to View Pricing, Inventory, Delivery & Lifecycle Information:

[Switchcraft:](#)

[2C1072](#)