

1050QC, 1051QC, 1052QC, 1053QC and 1090QC Series Non-Relampable Neon-Incandescent Indicator Lights

Description and Features

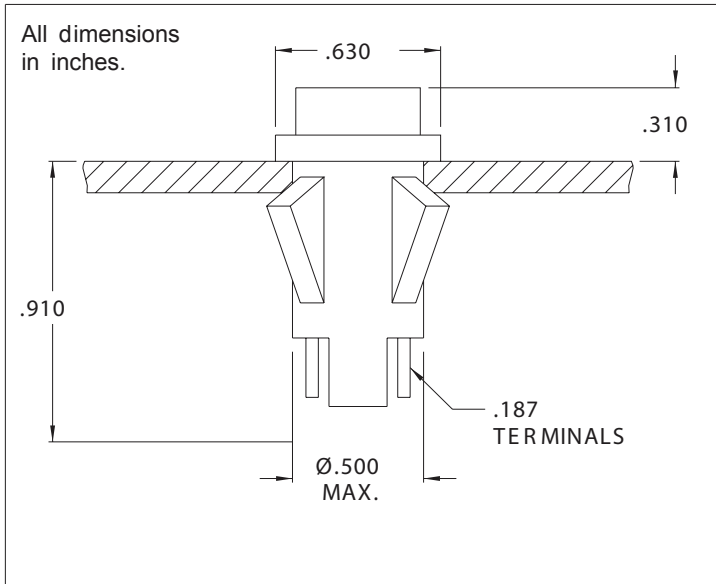

Mounting: Will snap-fit into Ø.500/.505 hole in panels .020/.100 thick. Push-on speednut SN0461 also available. Mounting hole pattern on page SP2.

Terminals: Tinned brass

Lens: Polycarbonate

Bezel: Polished stainless steel.

Housing: White Nylon

Lens Color	Neon		Incandescent	
	Model No. (105-125VAC)	Model No. (208-250V)	Model No. (12V)	Model No. (28V)
Red	1050QC 1	1051QC 1	1090QC 1-12V	1090QC 1-28V
Clear	1050QC 2	-	-	-
Amber	1050QC 3	1051QC 3	-	1090QC 3-28V
White	1050QC 4	1051QC 4	1090QC 4-12V	1090QC 4-28V
Green	1052QC 5*	1053QC 5*	1090QC 5-12V	1090QC 5-28V
Lamp used	C 2A+R resistor	C 2A+R resistor	#2162	#2187

* Incorporates G2B lamp and resistor.
Underwriters Laboratories (UL) File No. E20356

Mouser Electronics

Authorized Distributor

Click to View Pricing, Inventory, Delivery & Lifecycle Information:

VCC:

[1090QC5-12V](#) [1090QC4-12V](#) [1050QCX2](#)