

PLEASE CHECK WWW.MOLEX.COM FOR LATEST PART INFORMATION

Part Number: [0355070500](#)
Status: **Active**
Overview: [Sherlock Wire-to-Board Connector System](#)
Description: 2.00mm Pitch Sherlock Wire-to-Board Housing, Natural, 5 Circuits

Documents:

3D Model	Product Specification PS-35507-003-001 (PDF)
3D Model (PDF)	Packaging Specification 355070200-100 (PDF)
Drawing (PDF)	Packaging Specification PK-35507-001-001 (PDF)
Product Specification PS-35507-001-001 (PDF)	RoHS Certificate of Compliance (PDF)

Agency Certification

CSA	LR19980
UL	E29179

General

Product Family	Crimp Housings
Series	35507
Application	Signal, Wire-to-Board
Overview	Sherlock Wire-to-Board Connector System
Product Name	Sherlock
Taxonomy	Connector Housings
UPC	800754241878

Physical

Circuits (maximum)	5
Circuits Detail	5
Color - Resin	Natural
Flammability	94V-0
Gender	Receptacle
Glow-Wire Capable	No
Keying to Mating Part	None
Lock to Mating Part	Yes
Material - Resin	Polyester
Net Weight	0.253/g
Number of Rows	1
Packaging Type	Bag
Panel Mount	No
Pitch - Mating Interface	2.00mm
Polarized to Mating Part	Yes
Stackable	No
Temperature Range - Operating	-40° to +105°C

Electrical

Current - Maximum per Contact	2.0A
-------------------------------	------

Material Info

Reference - Drawing Numbers

Packaging Specification	355070200-100, PK-35507-001-001
Product Specification	PS-35507-001-001, PS-35507-003-001
Sales Drawing	SD-35507-001-001, SD-35507-001-002, SD-35507-001-003

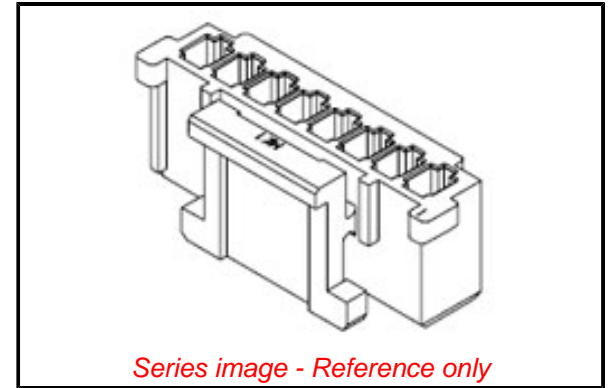

EU ELV

Compliant

EU RoHS

Compliant

REACH SVHC

Not Contained per -
D(2022)9120-DC (17
Jan 2023)

Halogen-Free

Status

Not Low-Halogen

For more information, please visit [Contact US](#)

China ROHS

ELV

RoHS Phthalates

China RoHS

Green Image

Compliant

Not Contained

Search Parts in this Series

[35507](#) Series

Mates With

Sherlock Wire-to-Board Header [35362](#) ,
[35363](#)

Use With

2.00mm Pitch Crimp Terminal [50212](#)