

**CONNECTOR DESIGNATOR:**
**H** MIL-DTL-38999, Series III and IV  
EN3645

**Finish**
*N* = Electroless Nickel

*X* = Aluminum, Nickel Fluorocarbon Polymer

*W* = 1,000 Hr. Cadmium Olive Drab  
over Electroless Nickel

*Z* = Aluminum, Zinc-Nickel, Black

**M85049/78**
**- 11**
**W**
**01**
**Basic  
Part Number**
**Shell Size  
(Tables I & II)**
**Clamp Size  
(Tables II & III)**
**TABLE I: Shell Size,  
Thread and Dimensions**

Shell Size	A Thread Class 2B	B Dia Max
09	M12 X 1 - 6H	.750 (19.1)
11	M15 X 1 - 6H	.850 (21.6)
13	M18 X 1 - 6H	1.000 (25.4)
15	M22 X 1 - 6H	1.150 (29.2)
17	M25 X 1 - 6H	1.250 (31.8)
19	M28 X 1 - 6H	1.400 (35.6)
21	M31 X 1 - 6H	1.550 (39.4)
23	M34 X 1 - 6H	1.650 (41.9)
25	M37 X 1 - 6H	1.850 (47.0)

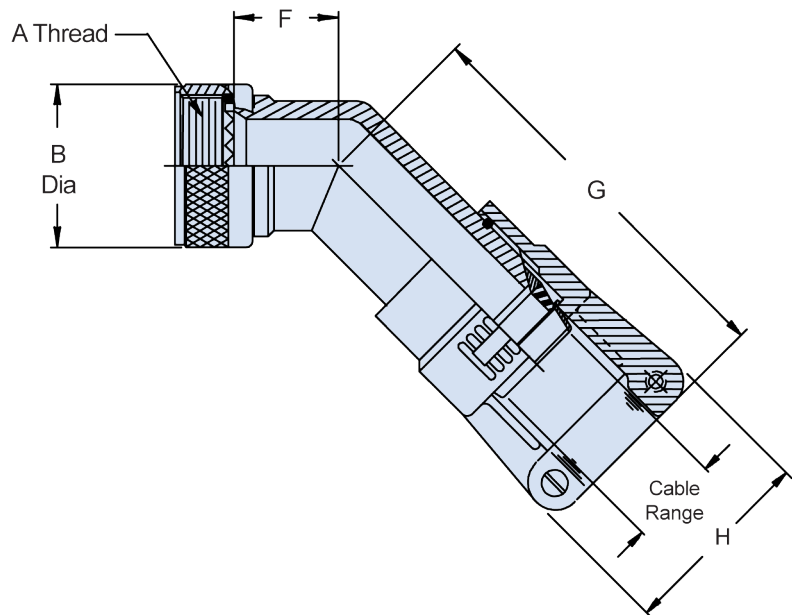
**TABLE II: Shell Size,  
Clamp Size and Dimensions**

Shell Size	Clamp Size		F ±.062 (1.6)	G ±.062 (1.6)
	Min	Max		
09	01	02	.398 (10.1)	3.088 (78.4)
11	01	03	.458 (11.6)	3.148 (80.0)
13	02	04	.518 (13.2)	3.208 (81.5)
15	02	05	.588 (14.9)	3.298 (83.8)
17	02	06	.678 (17.2)	3.408 (86.6)
19	03	07	.868 (22.0)	3.598 (91.4)
21	03	08	.868 (22.0)	3.598 (91.4)
23	03	09	.958 (24.3)	3.748 (95.2)
25	04	10	.958 (24.3)	3.748 (95.2)

**APPLICATION NOTES**

- For complete dimensions see the applicable Military Specification.
- Metric dimensions (mm) are in parentheses.
- Cable Range is defined as the accommodation range for the wire bundle or cable. Dimensions shown are not intended for inspection criteria.

**TABLE III: Clamp Size,  
Cable Range and Dimensions**

Clamp Size	Cable Range		H Max
	Min	Max	
01	.062 (1.6)	.125 (3.2)	.800 (20.3)
02	.125 (3.2)	.250 (6.4)	1.000 (25.4)
03	.250 (6.4)	.375 (9.5)	1.100 (27.9)
04	.375 (9.5)	.500 (12.7)	1.200 (30.5)
05	.500 (12.7)	.625 (15.9)	1.250 (31.8)
06	.625 (15.9)	.750 (19.1)	1.400 (35.6)
07	.750 (19.1)	.875 (22.2)	1.500 (38.1)
08	.875 (22.2)	1.000 (25.4)	1.650 (41.9)
09	1.000 (25.4)	1.125 (28.6)	1.750 (44.5)
10	1.125 (28.6)	1.250 (31.8)	1.900 (48.3)

Dimensions in inches (millimeters) and are subject to change without notice.