

Gas Discharge Tube Diodes

2R075~2R800(T,S)B/D-8 Series

GDTs (Gas Discharge Tubes) are placed in front of, and in parallel with, sensitive telecom equipment such as power lines, communication lines, signal lines and data transmission lines to help protect them from damage caused by transient surge voltages that may result from lightning strikes and equipment switching operations. These devices do not influence the signal in normal operation. However, in the event of an overvoltage surge, such as a lightning strike, the GDT switches to a low impedance state and diverts the energy away from the sensitive equipment.

GDTs offer a high level of surge protection, a broad voltage range, low capacitance, and many form factors including new surface mount devices, which makes them suitable for applications such as MDF (Main Distribution Frame) modules, high data-rate telecom applications (e.g. ADSL, VDSL), and surge protection on power lines. Their low capacitance also results in less signal distortion. When used in a coordinated circuit protection solution with PTC devices, TSS thyristor surge protection devices, and MOV (Metal Oxide Varistor) devices, they can help equipment manufacturers meet

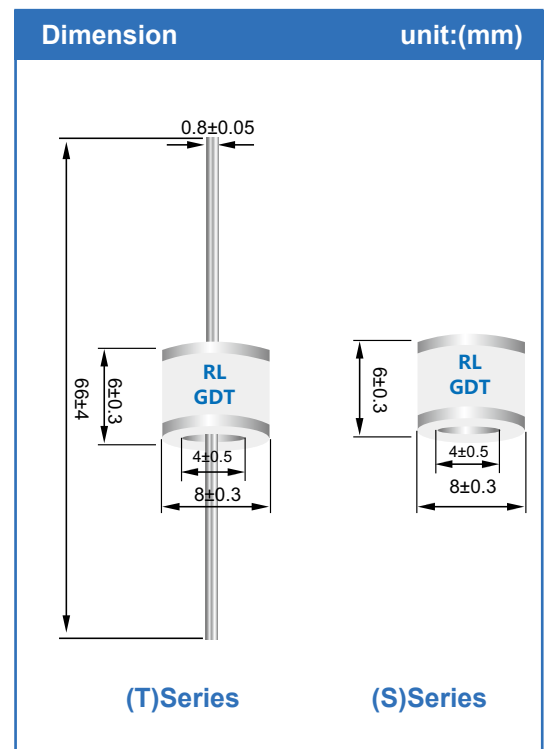

Features

- RoHS compliant and Lead-free
- GHz working frequency
- Excellent stability on multiple pulse duty cycle
- Excellent response to fast rising transients.
- Ultra Low Insertion Loss
- 5KA/10KA surge capability tested with 8/20 μ S pulse as defined by IEC 6100-4-5
- Ultra small devices offered in a variety of mounting lead forms
- Non-Radioactive
- Low capacitance (<1.5pF)
- Voltage Ranges 75V to 800V
- UL recognized
- Conforms to ITU-T K12, IEC6100-4-5

Applications

- Communication equipment
- CATV equipment
- Test equipment
- Data lines
- Power supplies
- Telecom SLIC protection
- Broadband equipment
- ADSL equipment including ADSL2+
- XDSL equipment
- Satellite and CATV equipment
- General telecom equipment

Electrical Characteristics

Type number	DC Spark-over voltage	Maximum Impulse spark-over voltage	Impulse life	Minimum Insulation resistance		Maximum Capacitance	Maximum surge Discharge Current	Alternating Discharge Current
	100v/s	1kv/us	10/1000us, 100A	Test Voltage	GΩ	1MHz	@8/20us, 10times	50Hz 1S
	V	V	Times	DC(V)		pF	KA	A
2R075(T,S)B-8	75±20%	600	500 times	DC 25V >1	1.5 pF	10KA	10A	
2R090(T,S)B-8	90±20%	600		DC 50V >1				
2R150(T,S)B-8	150±20%	700		DC 100V >1				
2R230(T,S)B-8	230±20%	800						
2R300(T,S)B-8	300±20%	900						
2R350(T,S)B-8	350±20%	1000						
2R400(T,S)B-8	400±20%	1000		DC 250V >1				
2R420(T,S)B-8	420±20%	1200						
2R470(T,S)B-8	470±20%	1200						
2R600(T,S)B-8	600±20%	1300						
2R800(T,S)D-8	800±20%	1500						
2R075(T,S)D-8	75±20%	600		DC 25V >1		20KA	20A	
2R090(T,S)D-8	90±20%	600		DC 50V >1				
2R150(T,S)D-8	150±20%	700		DC 100V >1				
2R230(T,S)D-8	230±20%	700						
2R300(T,S)D-8	300±20%	800						
2R350(T,S)D-8	350±20%	1000						
2R400(T,S)D-8	400±20%	1000		DC 250V >1				
2R420(T,S)D-8	420±20%	1200						
2R470(T,S)D-8	470±20%	1200						
2R600(T,S)D-8	600±20%	1300						
2R800(T,S)D-8	800±20%	1500						

Notes:

1. Insulation resistance measure at:

DC 50V for the 2R075, 2R090, and 2R150

DC 200V for other.

2. Terms in accordance with ITU-T K.12 and GB/T 9043-2008

3. At delivery AQL 0.65 level 2 DIN ISO 2859

Soldering Parameters - Reflow Soldering (Surface Mount Devices)

Reflow Condition		Pb – Free assembly
Pre Heat	- Temperature Min ($T_{s(min)}$)	150°C
	- Temperature Max ($T_{s(max)}$)	200°C
	- Time (Min to Max) (t_s)	60 – 180 secs
Average ramp up rate (Liquidus Temp (T_L) to peak)		3°C/second max
$T_{s(max)}$ to T_L - Ramp-up Rate		5°C/second max
Reflow	- Temperature (T_L) (Liquidus)	217°C
	- Temperature (t_L)	60 – 150 seconds
Peak Temperature (T_p)		260 ^{+0/-5} °C
Time within 5°C of actual peak Temperature (t_p)		10 – 30 seconds
Ramp-down Rate		6°C/second max
Time 25°C to peak Temperature (T_p)		8 minutes Max.
Do not exceed		260°C

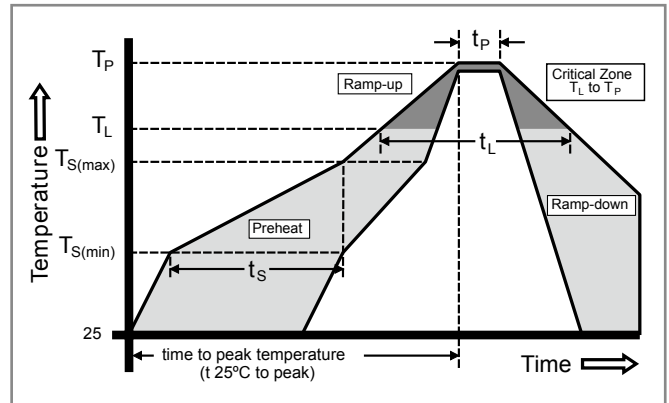

Soldering Parameters - Wave Soldering (Thru-Hole Devices)

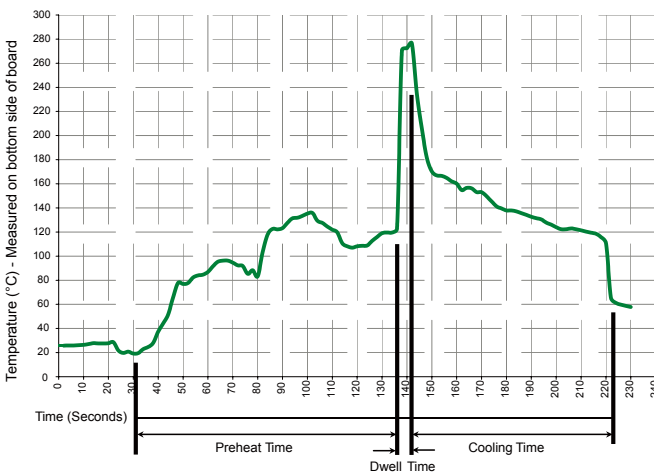

Recommended Process Parameters:

Wave Parameter	Lead-Free Recommendation
Preheat: (Depends on Flux Activation Temperature) (Typical Industry Recommendation)	
Temperature Minimum:	100° C
Temperature Maximum:	150° C
Preheat Time:	60-180 seconds
Solder Pot Temperature:	280° C Maximum
Solder Dwell Time:	2-5 seconds

Soldering Parameters - Hand Soldering

Solder Iron Temperature: 350° C +/- 5°C

Heating Time: 5 seconds max.

Packaging Dimensions

For 'T' Type Axial Lead Items

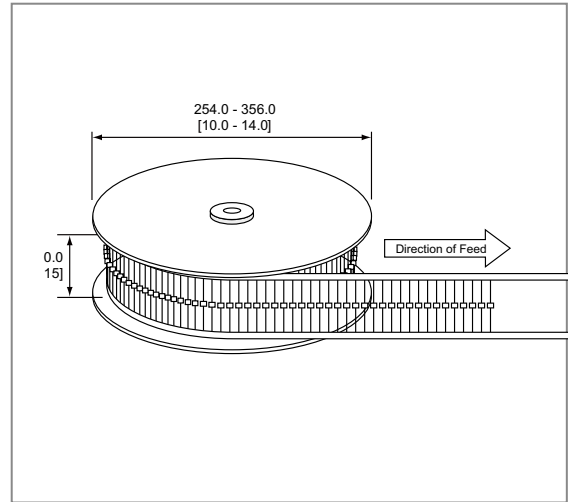
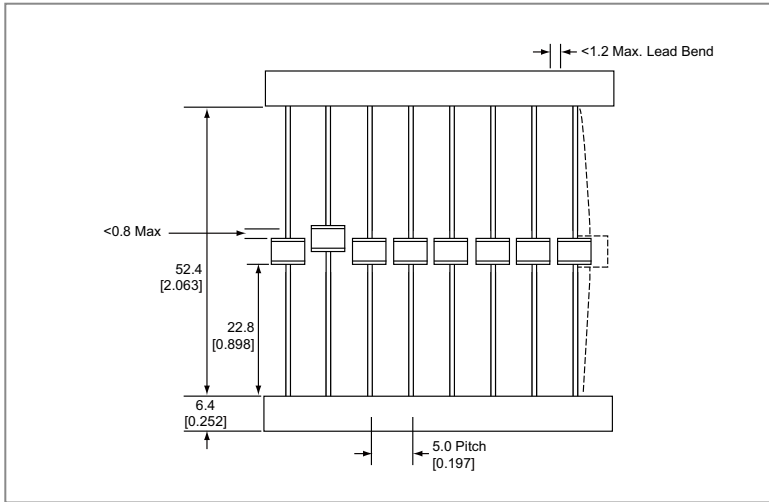

Core and 'MS' Type Items

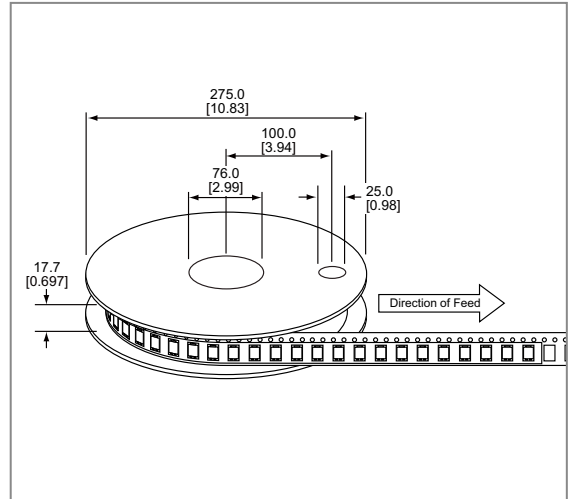
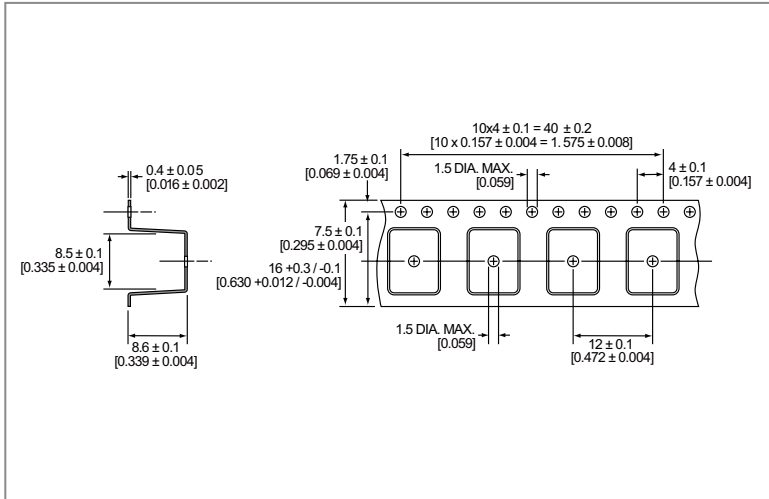

For 'LS' Type Shaped Lead Items

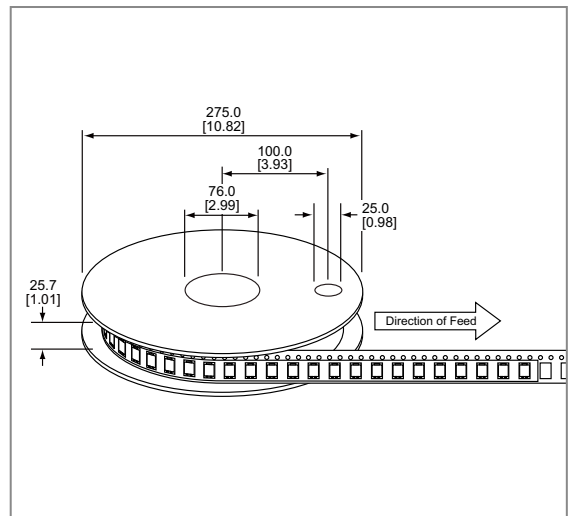
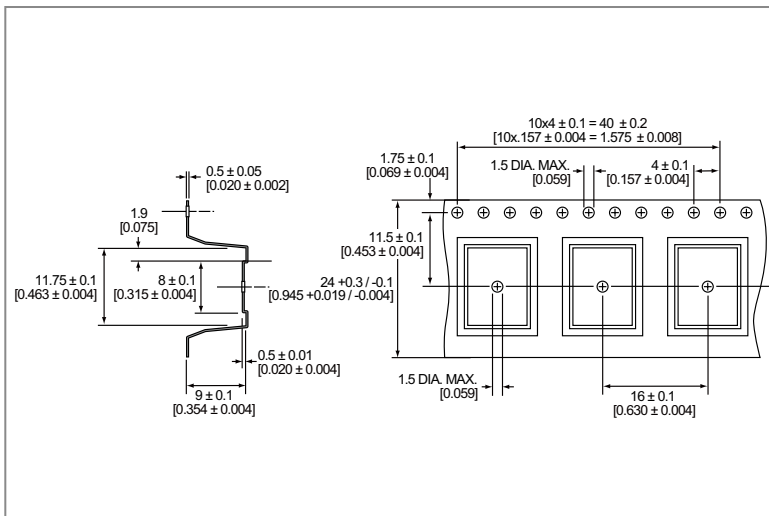

Part Number Code

