



NHS3152

Therapy adherence resistive monitor

Rev. 5.02 — 27 May 2021

Product data sheet

1 General description

The NHS3152 is an IC optimized for therapy adherence monitoring and logging. It has an embedded NFC interface, a resistive network sensing-interface, an internal temperature sensor, and a direct battery connection. These features support an effective system solution with a minimal number of external components and a single layer foil implementation for pill usage monitoring. The NHS3152 works either battery-powered or NFC-powered.

The embedded Arm Cortex-M0+ offers flexibility to the users of this IC to implement their own dedicated solution. The NHS3152 contains multiple features, including multiple power-down modes and a selectable CPU frequency of up to 8 MHz, for ultra low power consumption.

Users can program this NHS3152 with the industry-wide standard solutions for Arm Cortex-M0+ processors.

As of September 25, 2017, the NFC Forum has certified this device (certification ID: 58524).

CAUTION



Semiconductors are light sensitive. Exposure to light sources can cause the IC to malfunction. The IC must be protected against light. The protection must be applied to all sides of the IC.

CAUTION



This device is sensitive to ElectroStatic Discharge (ESD). Observe precautions for handling electrostatic sensitive devices. Such precautions are described in the *ANSI/ESD S20.20*, *IEC/ST 61340-5*, *JESD625-A* or equivalent standards.



2 Features and benefits

2.1 System

- ARM Cortex-M0+ processor running at frequencies of up to 8 MHz
- ARM Cortex-M0+ built-in Nested Vectored Interrupt Controller (NVIC)
- ARM Serial Wire Debug (SWD)
- System tick timer
- IC reset input

2.2 Memory

- 32 kB on-chip flash programming memory
- 4 kB on-chip EEPROM of which 320 bytes are write-protected
- 8 kB SRAM

2.3 Digital peripherals

- Up to 12 general-purpose input output (GPIO) pins with configurable pull-up/pull-down resistors and repeater mode
- GPIO pins which can be used as edge and level sensitive interrupt sources
- High-current drivers (sink only; 20 mA) on four GPIO pins
- High-current drivers (sink only; 20 mA) on two I²C-bus pins
- Programmable watchdog timer (WDT)

2.4 Analog peripherals

- Temperature sensor with:
 - ± 0.5 °C absolute temperature accuracy between -40 °C and 0 °C
 - ± 0.3 °C absolute temperature accuracy between 0 °C and $+45$ °C
 - ± 0.5 °C absolute temperature accuracy between $+45$ °C and $+85$ °C
- Analog-to-Digital Converter (ADC)
- Digital-to-Analog Converter (DAC)
- Current-to-Digital Converter (CDC)
- 6 analog I/O pins

2.5 Flexible analog on-chip switch

- Each of the six I/O pins can be dynamically connected to the on-chip converters.
- One instance of each converter is implemented
- Measuring six voltages connected to the six pins is possible using time-division multiplexing. Other combinations are possible

2.6 Communication interfaces

- NFC/RFID ISO 14443 type A interface; NFC Forum type 2 compatible
- I²C-bus interface supporting full I²C-bus specification and fast mode with a data rate of 400 kbit/s, with multiple-address recognitions and monitor mode

2.7 Clock generation

- 8 MHz internal RC oscillator, trimmed to 2 % accuracy, which is used for the system clock
- Timer oscillator operating at 32 kHz linked to the RTC timer unit

2.8 Power control

- Support for 1.72 V to 3.6 V external voltages
- The NHS3152 can also be powered from the NFC field.
- Activation via NFC possible
- Integrated power management unit (PMU) for versatile control of power consumption
- Four reduced power modes for Arm Cortex-M0+: sleep, deep-sleep, deep power-down, and battery-off
- Power gating for each analog peripheral for ultra-low power operation
- < 50 nA IC current consumption in battery-off mode at 3.0 V
- Power-on reset (POR)

2.9 General

- Unique device serial number for identification

3 Applications

- Therapy adherence monitoring and logging

4 Ordering information

Table 1. Ordering information

Type number	Package		Version
	Name	Description	
NHS3152	HVQFN24	plastic thermal enhanced very thin quad flat package; no leads; 24 terminals; body 4 × 4 × 0.85 mm	SOT616-3
NHS3152UK	WLCSP25	wafer level chip-scale package; 25 balls; 2.51 × 2.51 × 0.5 mm	SOT1401-1

5 Marking

Table 2. Marking codes

Type number	Marking code
NHS3152	NHS3152
NHS3152UK	NHS3152

6 Block diagram

Figure 1 shows the internal block diagram of the NHS3152. It includes a power management unit (PMU), clocks, timers, a digital computation, a control cluster (Arm Cortex-M0+ and memories), and AHB-APB slave modules.

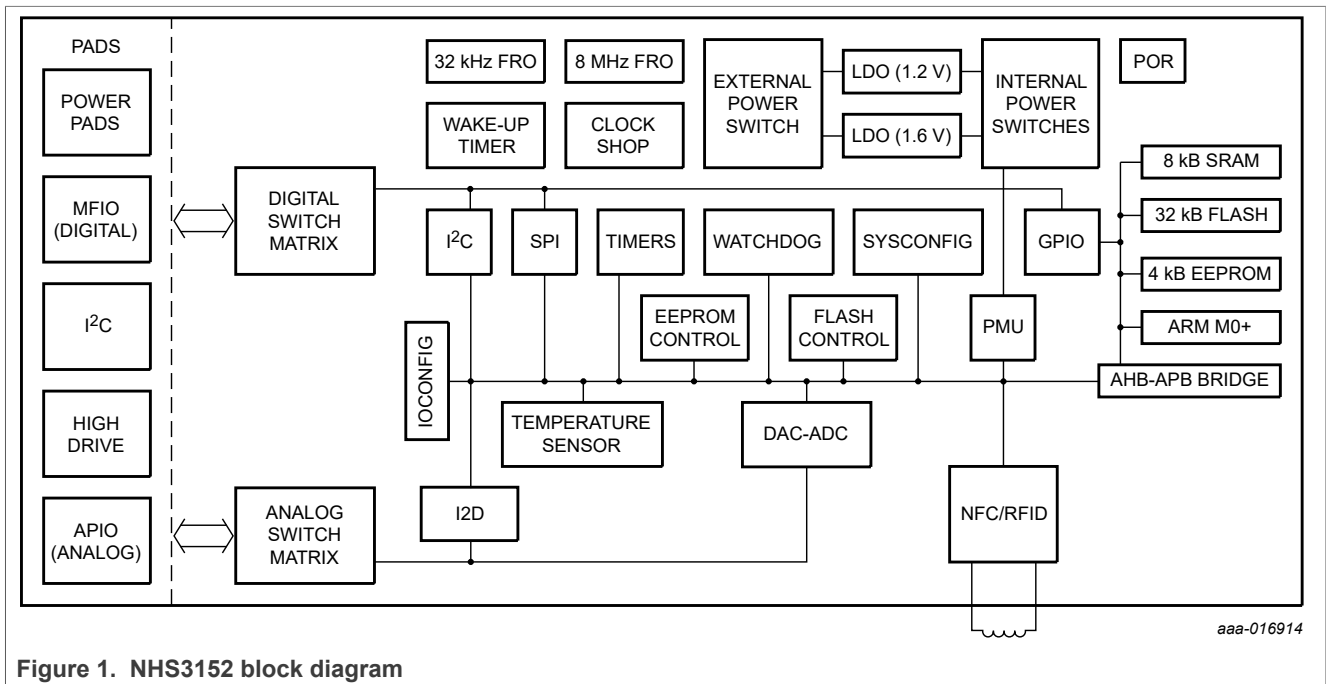

Figure 1. NHS3152 block diagram

7 Pinning

The pin functionality depends on the particular configuration of the chip and is application-dependent. Pin functions are software-assigned through the IOCON configuration registers. The pinning of the packages is shown below.

7.1 HVQFN24

Figure 2 shows the pad layout of the NHS3152 in the HVQFN24 package.

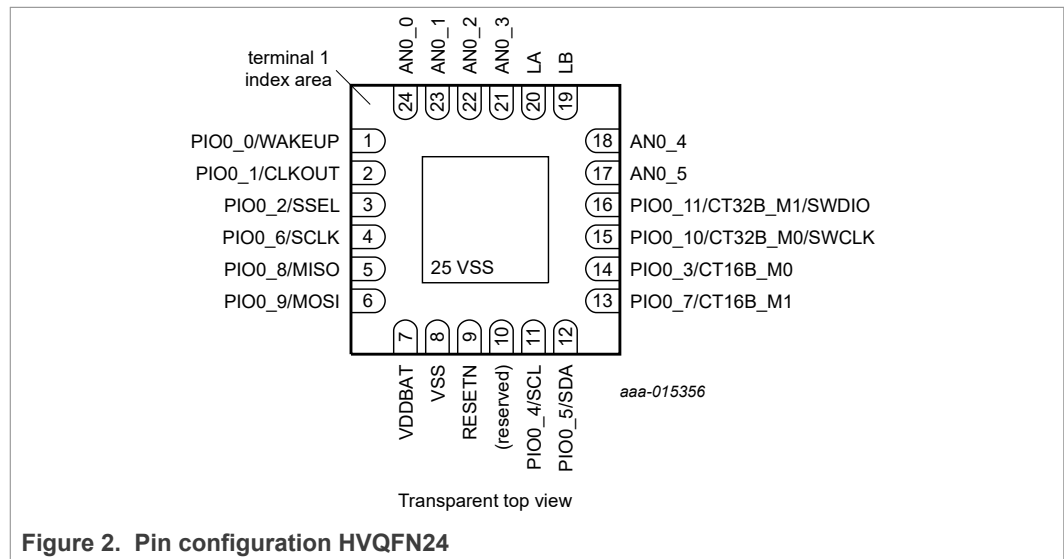

Table 3. Pad allocation table of the HVQFN24 package

Pad	Symbol	Pad	Symbol
1	PIO0_0/WAKEUP	13 ^[1]	PIO0_7/CT16B_M1
2	PIO0_1/CLKOUT	14 ^[1]	PIO0_3/CT16B_M0
3	PIO0_2/SSEL	15 ^[1]	PIO0_10/CT32B_M0/SWCLK
4	PIO0_6/SCLK	16 ^[1]	PIO0_11/CT32B_M1/SWDIO
5	PIO0_8/MISO	17	AN0_5
6	PIO0_9/MOSI	18	AN0_4
7	VDDBAT	19	LB
8	VSS	20	LA
9	RESETN	21	AN0_3
10	(reserved)	22	AN0_2
11	PIO0_4/SCL	23	AN0_1
12	PIO0_5/SDA	24	AN0_0

[1] High source current pads. See Section 8.7.3.

Table 4. Pad description of the HVQFN24 package

Pad	Symbol	Type	Description
Supply			
7	VDDBAT	supply	positive supply voltage
8	VSS	supply	ground
GPIO^[1]			
1	PIO0_0	I/O	GPIO
	WAKEUP	I	deep power-down mode wake-up pin ^[2]
2	PIO0_1	I/O	GPIO
	CLKOUT	O	clock output
3	PIO0_2	I/O	GPIO
	SSEL	I	SPI/SSP serial select line
14	PIO0_3	I/O	GPIO
	CT16B_M0	O	16-bit timer match output 0
11	PIO0_4	I/O	GPIO ^[3]
	SCL	I/O	I ² C-bus SCL clock line
12	PIO0_5	I/O	GPIO ^[3]
	SDA	I/O	I ² C-bus SDA data line
4	PIO0_6	I/O	GPIO
	SCLK	I/O	SPI/SSP serial clock line
13	PIO0_7	I/O	GPIO
	CT16B_M1	O	16-bit timer match output 1
5	PIO0_8	I/O	GPIO
	MISO	O	SPI/SSP master-in slave-out line
6	PIO0_9	I/O	GPIO
	MOSI	I	SPI/SSP master-out slave-in line
15	PIO0_10	I/O	GPIO
	CT32B_M0	O	32-bit timer match output 0
	SWCLK	I	Arm SWD clock
16	PIO0_11	I/O	GPIO
	CT32B_M1	O	32-bit timer match output 1
	SWDIO	I/O	Arm SWD I/O
Analog I/O^[4]			
24	AN0_0	A	to AN0_BUS0
23	AN0_1	A	to AN0_BUS1
22	AN0_2	A	to AN0_BUS2
21	AN0_3	A	to AN0_BUS3
18	AN0_4	A	to AN0_BUS4

Table 4. Pad description of the HVQFN24 package...continued

Pad	Symbol	Type	Description
17	AN0_5	A	to AN0_BUS5
Radio			
20	LA	A	NFC antenna/coil terminal A
19	LB	A	NFC antenna/coil terminal B
Reset			
9	RESETN	I	external reset input ^[5]

- [1] The GPIO port is a 12-bit I/O port with individual direction and function controls for each bit. The operation of port 0 pads depends on the function selected through the IOCONFIG register block.
- [2] If external wake-up is enabled on this pad, it must be pulled HIGH before entering deep power-down mode and pulled LOW for a minimum of 100 μs to exit deep power-down mode.
- [3] Open drain, no pull-up or pull down.
- [4] The analog port is a 6-input analog I/O port with enable control for each pad.
- [5] A LOW on this pin resets the device. This reset causes I/O ports and peripherals to take on their default states, and processor execution to begin at address 0. It has weak pull-up to V_{BAT} or internal NFC voltage (whichever is highest).

7.2 WLCSP25

Figure 3 shows the ball layout of the NHS3152 in the WLCSP25 package.

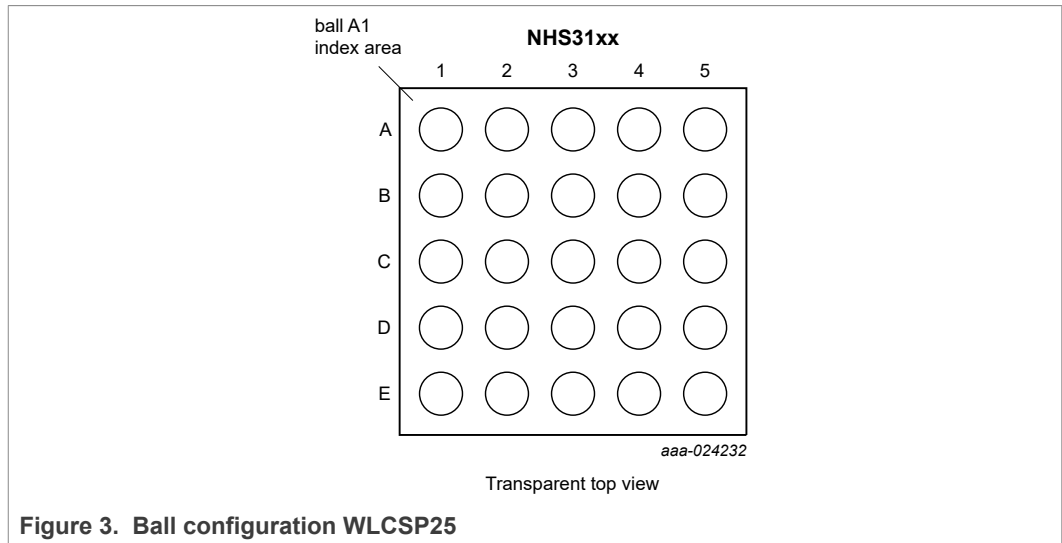

Figure 3. Ball configuration WLCSP25

Table 5. Ball allocation table of the WLCSP25 package

Ball	Symbol	Ball	Symbol
A1	VDDBAT	C4 ^[1]	PIO0_7/CT16B_M1
A2	VSS	C5 ^[1]	PIO0_11/CT32B_M1/SWDIO
A3	RESETN	D1	PIO0_0/WAKEUP
A4	PIO0_4/SCL	D2	PIO0_1/CLKOUT
A5	PIO0_5/SDA	D3	AN0_2
B1	PIO0_8/MISO	D4	AN0_4
B2	PIO0_9/MOSI	D5	AN0_5

Table 5. Ball allocation table of the WLCSP25 package...continued

Ball	Symbol	Ball	Symbol
B3	(reserved)	E1	AN0_0
B4 ^[1]	PIO0_3/CT16B_M0	E2	AN0_1
B5 ^[1]	PIO0_10/CT32B_M0/SWCLK	E3	AN0_3
C1	PIO0_2/SSEL	E4	LA
C2	PIO0_6/SCLK	E5	LB
C3	VSS	-	-

[1] High source current balls. See [Section 8.7.3](#).

Table 6. Ball description of the WLCSP25 package

Ball	Symbol	Type	Description
Supply			
A1	VDDBAT	supply	positive supply voltage
A2, C3	VSS	supply	ground
GPIO^[1]			
D1	PIO0_0	I/O	GPIO
	WAKEUP	I	deep power-down mode wake-up ball ^[2]
D2	PIO0_1	I/O	GPIO
	CLKOUT	O	clock output
C1	PIO0_2	I/O	GPIO
	SSEL	I	SPI/SSP serial select line
B4	PIO0_3	I/O	GPIO
	CT16B_M0	O	16-bit timer match output 0
A4	PIO0_4	I/O	GPIO ^[3]
	SCL	I/O	I ² C-bus SCL clock line
A5	PIO0_5	I/O	GPIO ^[3]
	SDA	I/O	I ² C-bus SDA data line
C2	PIO0_6	I/O	GPIO
	SCLK	I/O	SPI/SSP serial clock line
C4	PIO0_7	I/O	GPIO
	CT16B_M1	O	16-bit timer match output 1
B1	PIO0_8	I/O	GPIO
	MISO	O	SPI/SSP master-in slave-out line
B2	PIO0_9	I/O	GPIO
	MOSI	I	SPI/SSP master-out slave-in line

Table 6. Ball description of the WLCSP25 package...continued

Ball	Symbol	Type	Description
B5	PIO0_10	I/O	GPIO
	CT32B_M0	O	32-bit timer match output 0
	SWCLK	I	Arm SWD clock
C5	PIO0_11	I/O	GPIO
	CT32B_M1	O	32-bit timer match output 1
	SWDIO	I/O	Arm SWD I/O
Analog I/O ^[4]			
E1	AN0_0	A	to AN0_BUS0
E2	AN0_1	A	to AN0_BUS1
D3	AN0_2	A	to AN0_BUS2
E3	AN0_3	A	to AN0_BUS3
D4	AN0_4	A	to AN0_BUS4
D5	AN0_5	A	to AN0_BUS5
Radio			
E4	LA	A	NFC antenna/coil terminal A
E5	LB	A	NFC antenna/coil terminal B
Reset			
A3	RESETN	I	external reset input ^[5]

[1] The GPIO port is a 12-bit I/O port with individual direction and function controls for each bit. The operation of port 0 pins depend on the function selected through the IOCONFIG register block.

[2] If external wake-up is enabled on this pad, it must be pulled HIGH before entering deep power-down mode and pulled LOW for a minimum of 100 μ s to exit deep power-down mode.

[3] Open drain, no pull-up or pull down.

[4] The analog port is a 6-input analog I/O port with enable control for each pad.

[5] A LOW on this pin resets the device. This reset causes I/O ports and peripherals to take on their default states, and processor execution to begin at address 0. It has weak pull-up to V_{BAT} or internal NFC voltage (whichever is highest).

8 Functional description

8.1 Arm Cortex-M0+ core

Refer to the Cortex-M0+ Devices Technical Reference Manual ([Ref. 1](#)) for a detailed description of the Arm Cortex-M0+ processor.

The NHS3152 Arm Cortex-M0+ core has the following configuration:

- System options
 - Nested vectored interrupt controller (NVIC)
 - Fast (single-cycle) multiplier
 - System tick timer
 - Support for wake-up interrupt controller
 - Vector table remapping register
 - Reset of all registers
- Debug options
 - Serial wire debug (SWD) with two watchpoint comparators and four breakpoint comparators
 - Halting debug is supported

8.2 Memory map

[Figure 4](#) shows the memory and peripheral address space of the NHS3152.

The only AHB peripheral device on the NHS3152 is the GPIO module. The APB peripheral area is 512 kB in size. Each peripheral is allocated 16 kB of space.

All peripheral register addresses are 32-bit word aligned. Byte and halfword addressing is not possible. All reading and writing are done per full word.

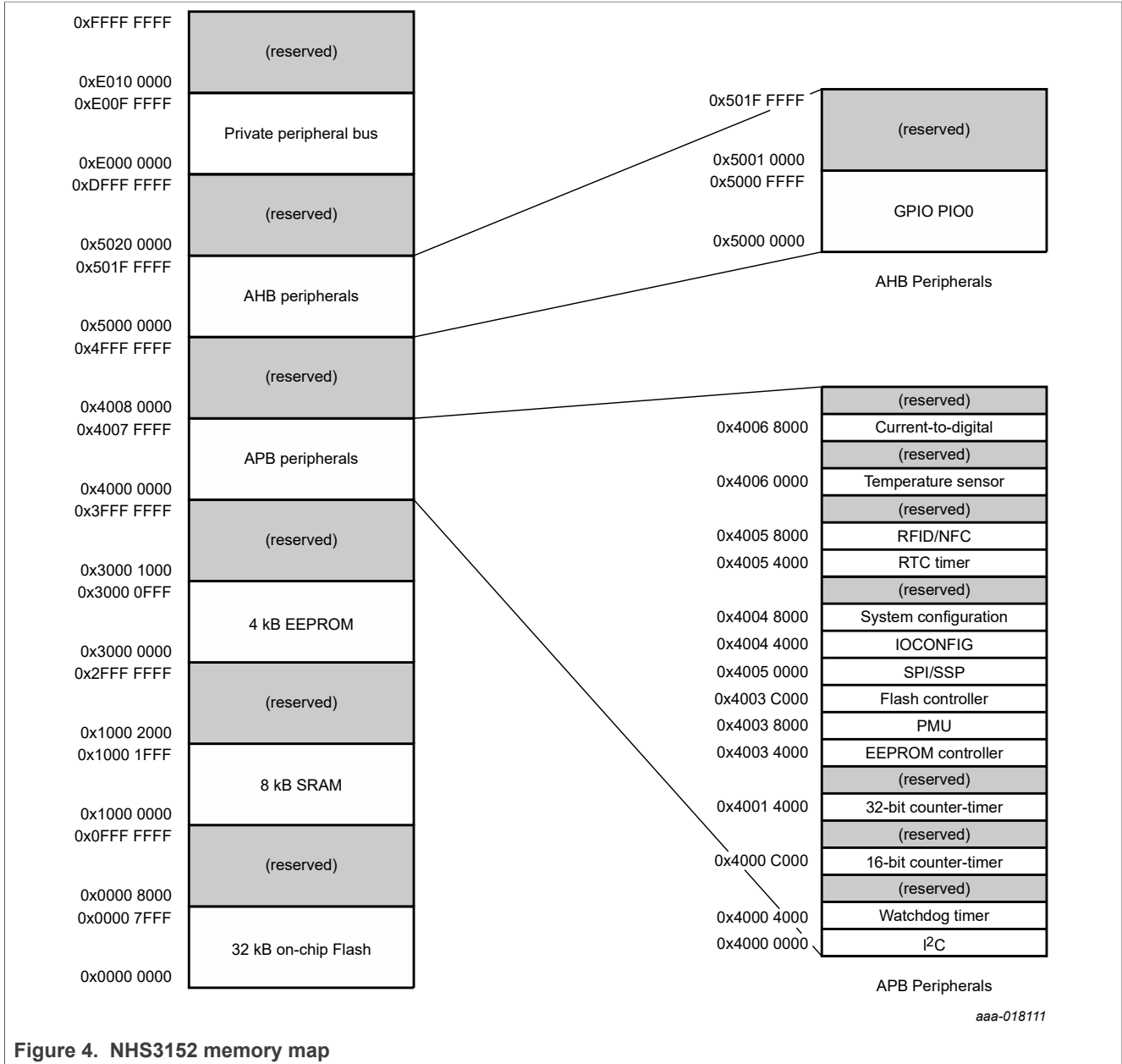

8.3 System configuration

The system configuration APB block controls oscillators, start logic, and clock generation of the NHS3152. Also included in this block is a register for remapping the interrupt vector table.

8.3.1 Clock generation

The NHS3152 clock generator unit (CGU) includes two independent RC oscillators. These oscillators are the system free-running oscillator (SFRO) and the timer free-running oscillator (TFRO).

The SFRO runs at 8 MHz. The system clock is derived from it and can be set to 8 MHz, 4 MHz, 2 MHz, 1 MHz, 500 kHz, 250 kHz, 125 kHz, or 62.5 kHz.

Note: Some features are not available when using the lower clock speeds.

The TFRO runs at 32.768 kHz and is the clock source for the timer unit. The TFRO cannot be disabled.

Following a reset, the NHS3152 starts operating at the default 500 kHz system clock frequency to minimize dynamic current consumption during the boot cycle.

The SYSAHBCLKCTRL register gates the system clock to the various peripherals and memories. The temperature sensor receives a fixed clock frequency, irrespective of the system clock divider settings, while the digital part uses the system clock (AHB clock 0).

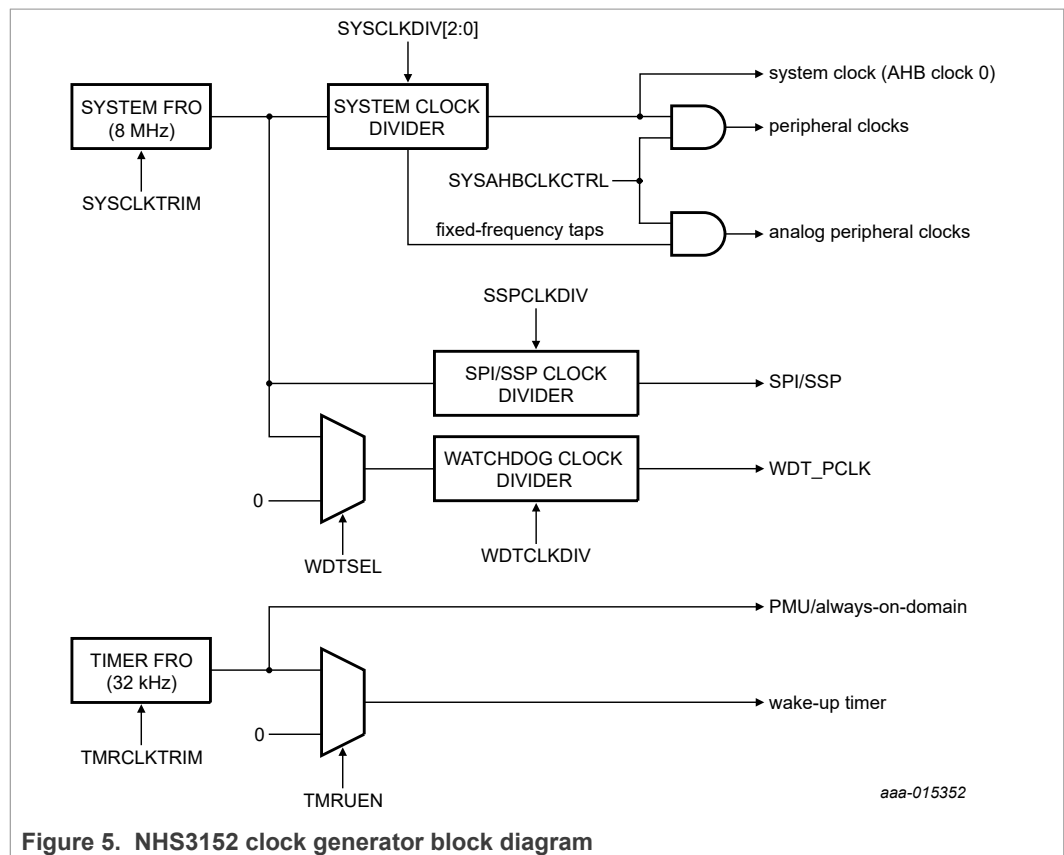

Figure 5. NHS3152 clock generator block diagram

8.3.2 Reset

Reset has three sources on the NHS3152:

- The RESETN pin
- Watchdog reset
- A software reset

8.4 Power management

The Power Management Unit (PMU) controls the switching between available power sources and the powering of the different voltage domains in the IC.

8.4.1 System power architecture

The NHS3152 accepts power from two different sources: from the external power supply pin VDDBAT, or from the built-in NFC/RFID rectifier.

The NHS3152 has a small automatic source selector that monitors the power inputs (VBAT and VNFC, see [Figure 6](#)) as well as pin RESETN. The PSWBAT switch is kept open until a trigger is given on pin RESETN or via the NFC field. If the trigger is given, the always-on domain, VDD_ALON, itself is powered via the PSWBAT or the PSWNFC switch: via VBAT, if $V_{BAT} > 1.72$ V, or VNFC. When both VBAT and VNFC are present, priority is given to VBAT.

The automatic source selector unit in the PMU decides on the powering of the internal domains based on the power source.

- If a voltage > 1.72 V is detected on VBAT and not VNFC, VBAT powers the internal domains after a trigger on pin RESETN or via NFC.
- If a voltage ≤ 1.72 V is detected on VBAT, and a higher voltage is detected on VNFC, the internal domains are powered from VNFC.
- If a voltage > 1.72 V is detected at both VBAT and VNFC, the internal domains are powered from VBAT.
- Switchover between power sources is possible. If initially VBAT and VNFC are available, the system is powered from VBAT. If VBAT then becomes unavailable (because it is switched off externally, or by a PSWBAT/PSWNFC power switch override), the internal domains are immediately powered from VNFC. Switchover is supported in both directions.
- The user can force the selection of the VBAT input by disabling the automatic power switch, which disables the automatic source selector voltage comparator.

When on NFC power only (passive operation), connecting one or more 100 nF external capacitors in parallel to a GPIO pad and setting that pad as an output driven to logic 1, is advised. A high-drive pin must be chosen and several pins can be connected in parallel.

PSWNFC and PSWBAT are the power switches. When an RF field is present, PSWNFC connects power to the VDD_ALON power net. When a positive edge is detected on RESETN, PSWBAT connects power from the battery. If no RF power is available, the PMU can open this PSWBAT switch, effectively switching off the device. After connecting VDDBAT to a power source, the PSWBAT switch is open until a rising edge is detected on RESETN or RF power is applied.

Each component of the NHS3152 resides in one of several internal power domains, as indicated in [Figure 6](#). The domains are VBAT, VNFC, VDD_ALON, VDD1V2, and VDD1V6. The domains VDD_ALON, VDD1V2 and VDD1V6 are either powered or not powered, depending on the mode of the NHS3152. There are 5 modes:

- Active
- Sleep
- Deep-sleep
- Deep power-down
- Battery-off

The VDD_ALON domain contains brownout detection (BOD). When enabled, it raises a BOD interrupt if the VDD_ALON voltage drops below 1.8 V.

The PMU controls the active, sleep, deep-sleep, and deep power-down modes. In this way, the power flows to the different internal components.

The PMU has two LDOs powering the internal VDD1V2 and VDD1V6 voltage domains. LDO1V2 converts voltages in the range 1.72 V to 3.6 V to 1.22 V. LDO1V6 converts voltages in the range 1.72 V to 3.6 V to 1.6 V. Each LDO can be enabled separately. When powered via VNFC, a 1.2 nF buffer capacitor is included at the input of the LDOs.

The trigger detector (not shown in Figure 6) and the power gate have a leakage of less than 50 nA, allowing a long shelf life before activation.

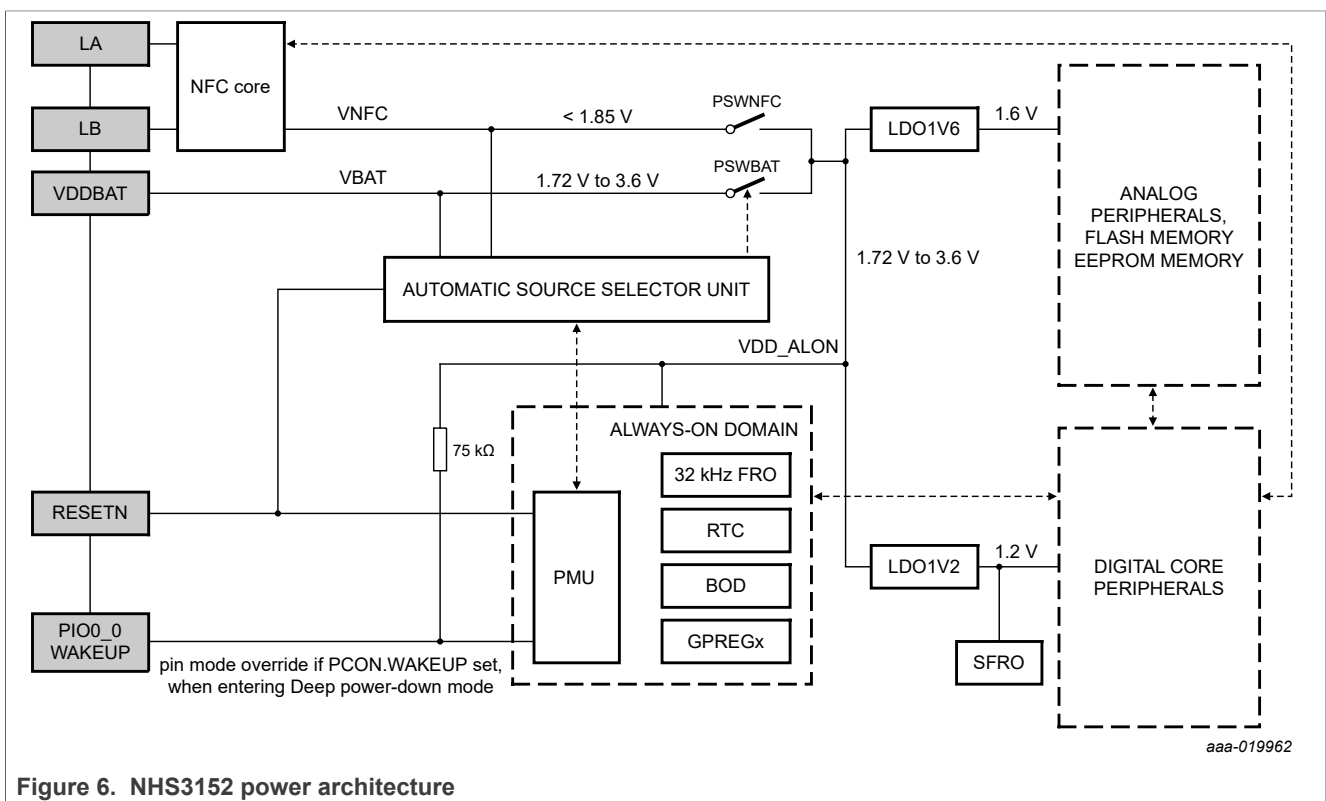

Figure 6. NHS3152 power architecture

Table 7 summarizes the PMU states and settings of the LDOs. Figure 7 shows the state transitions.

Table 8 and Table 9 summarize the events that can influence wake-up from deep power-down or deep-sleep modes (DEEPPDN or DEEPSLEEP to ACTIVE state transition).

Table 7. IC power states

State	VDD_ALON	DPDN ^[1]	Sleep or Deep-sleep	LDO1 (1.2 V)	LDO2 (1.6 V)
BATTERY-OFF (No power)	no	X ^[2]	X ^[2]	off	off
ACTIVE	yes	0	0	on	on
DEEPPDN	yes	1	0	off	off
SLEEP/DEEPSLEEP	yes	0	1	on	on

- [1] DPDN indicates whether the system is in Deep power-down mode.
- [2] X = don't care.

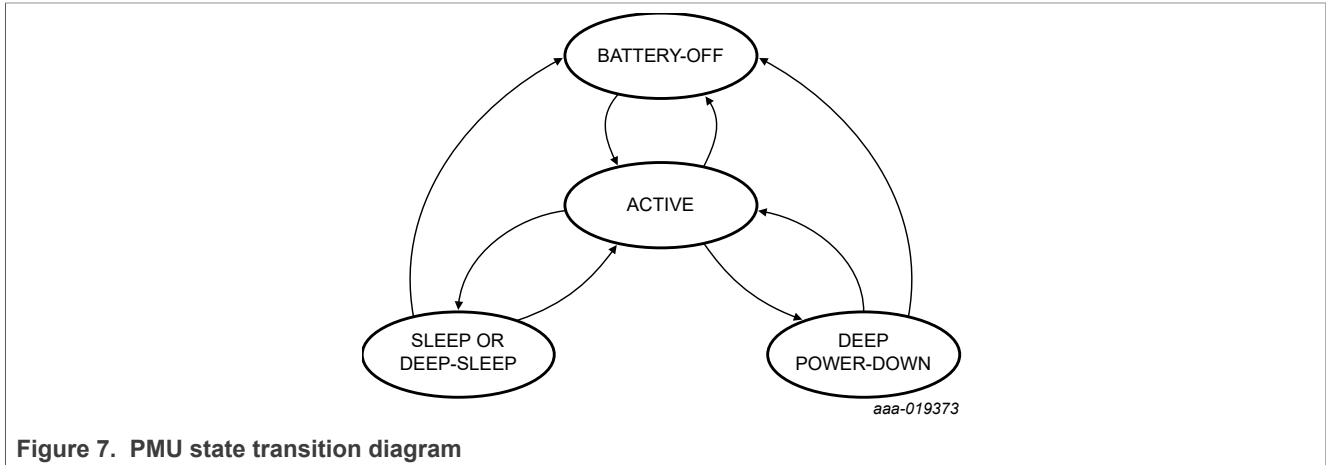

Figure 7. PMU state transition diagram

Figure 8 shows the power-up sequence. Applying battery power when the PSWBAT switch is closed, or NFC power becomes available, provides the always-on part with a Power-On Reset (POR) signal. The TFRO is initiated, which starts a state machine in the PMU. In the first state, the LDO1V2, powering the digital domain, is started. In the second state, the LDO1V6, powering the analog domain, is started which starts the flash memory. Enabling the LDO1V2, and the SFRO stabilizing, triggers the system_por. The system is now considered to be 'on'. The system can boot when the flash memory is fully operational.

The total start-up time from trigger to active mode/boot is about 2.5 ms.

If there is no battery power, but there is RF power, the same procedure is followed except that PSWNFC connects power to the LDOs.

The user cannot disable the TFRO as it is used by the PMU.

Table 8. State transition events for DEEPSLEEP to ACTIVE

Event	Description
RESETN	reset asserted
RTC event	if the timer reaches preset value
Watchdog	watchdog issues interrupt or reset
WAKEUP	signal on WAKEUP pin
RF field	RF field is detected, potential NFC command input (if set in PMU)
Start logic interrupt	one of the enabled start logic interrupts is asserted

Table 9. State transition events for DEEPPDN to ACTIVE

Event	Description
RESETN	reset asserted
RTC event	if the timer reaches preset value
WAKEUP	signal on WAKEUP pin (when enabled)

Table 9. State transition events for DEEPPDN to ACTIVE...continued

Event	Description
RF field	RF field is detected, potential NFC command input (if set in PMU)

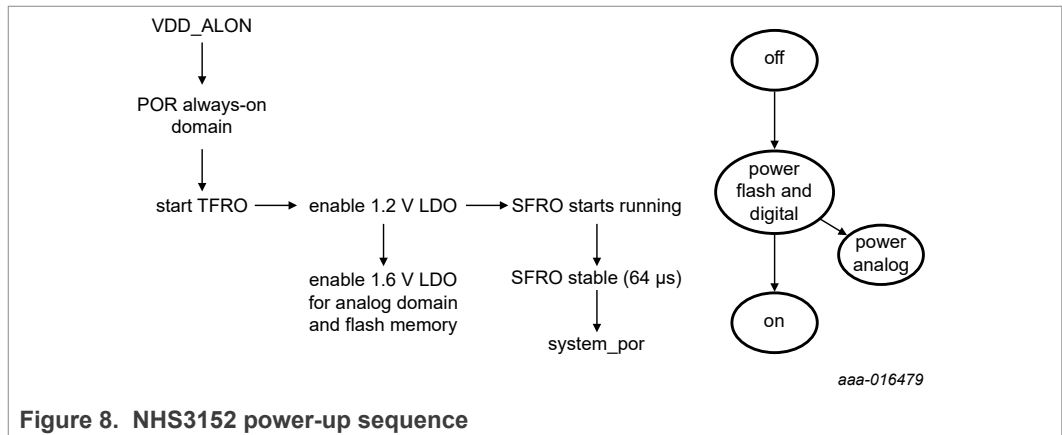

Figure 8. NHS3152 power-up sequence

8.4.2 Power management unit (PMU)

The power management unit (PMU) partly resides in the digital power domain and partly in the always-on domain. The PMU controls the sleep, deep-sleep, and deep power-down modes and the power flow to the different internal circuit blocks. Five general-purpose registers in the PMU can be used to retain data during deep power-down mode. These registers are located in the always-on domain. When configured, the PMU also raises a BOD interrupt if VDD_ALON drops to below 1.8 V.

The power to the different APB analog slaves is controlled through a power-down configuration register.

The power control register selects if an Arm Cortex-M0+ controlled power-down mode (sleep mode or deep-sleep mode) or the deep power-down mode is entered. It also provides the flags for sleep or deep-sleep modes and deep power-down mode respectively. In addition, it contains the overrides for the power source selection.

8.5 Nested Vectored Interrupt Controller (NVIC)

The Nested Vectored Interrupt Controller (NVIC) is a part of the ARM Cortex-M0+. The tight integration of the processor core and NVIC enables fast processing of interrupts, dramatically reducing the interrupt latency.

8.5.1 Features

- NVIC that is a part of the ARM Cortex-M0+
- Tightly coupled interrupt controller provides low interrupt latency
- Controls system exceptions and peripheral interrupts
- Four programmable interrupt priority levels with hardware priority level masking
- Software interrupt generation

8.5.2 Interrupt sources

[Table 10](#) lists the interrupt sources for each peripheral function. Each peripheral device may have one or more interrupt lines to the nested vectored interrupt controller. Each line may represent more than one interrupt source. There is no significance or priority about which line is connected where, except for certain standards from Arm.

Table 10. Connection of interrupt source to the nested vector interrupt controller

Exception number	Vector offset	Function	Flags
0 to 12	-	start logic wake-up interrupts	each interrupt connected to a PIO0 input pin serves as wake-up from deep-sleep mode ^[1]
13	-	RFID/NFC	RFID/NFC access detected/command received/read acknowledge
14	-	RTC On/Off timer	RTC on/off timer event interrupt
15	-	I ² C	Slave input (SI) (state change)
16	-	CT16B	16-bit timer
17	-	PMU	power from NFC field detected
18	-	CT32B	32-bit timer
19	-	BOD	brownout detection (power drop)
20	-	SPI/SSP	TX FIFO half empty/RX FIFO half full/RX time-out/RX overrun
21	-	TSENS	temperature sensor end of conversion/low threshold/high threshold
22 to 23	-	-	(reserved)
24	-	I2D	current-to-digital conversion interrupt
25	-	ADC DAC	ADC DAC interrupt
26	-	WDT	watchdog interrupt (WDINT)
27	-	flash	flash memory
28	-	EEPROM	EEPROM memory
29 to 30	-	-	(reserved)
31	-	PIO0	GPIO interrupt status of port 0

[1] Interrupt 0 to 10 correspond to PIO0_0 to PIO0_10; interrupt 11 corresponds to RFID/NFC external access; interrupt 12 corresponds to the RTC On/Off timer.

8.6 Analog signal buses

NHS3152 accepts several analog signals via its input pins ('ana_ext' bus). The ANA0_x registers in the IOCFG block control the ana_ext bus (see Section 8.7.4). Figure 9 schematically shows the bus structure.

The different converters connect through their own analog switch matrix to the bus lines.

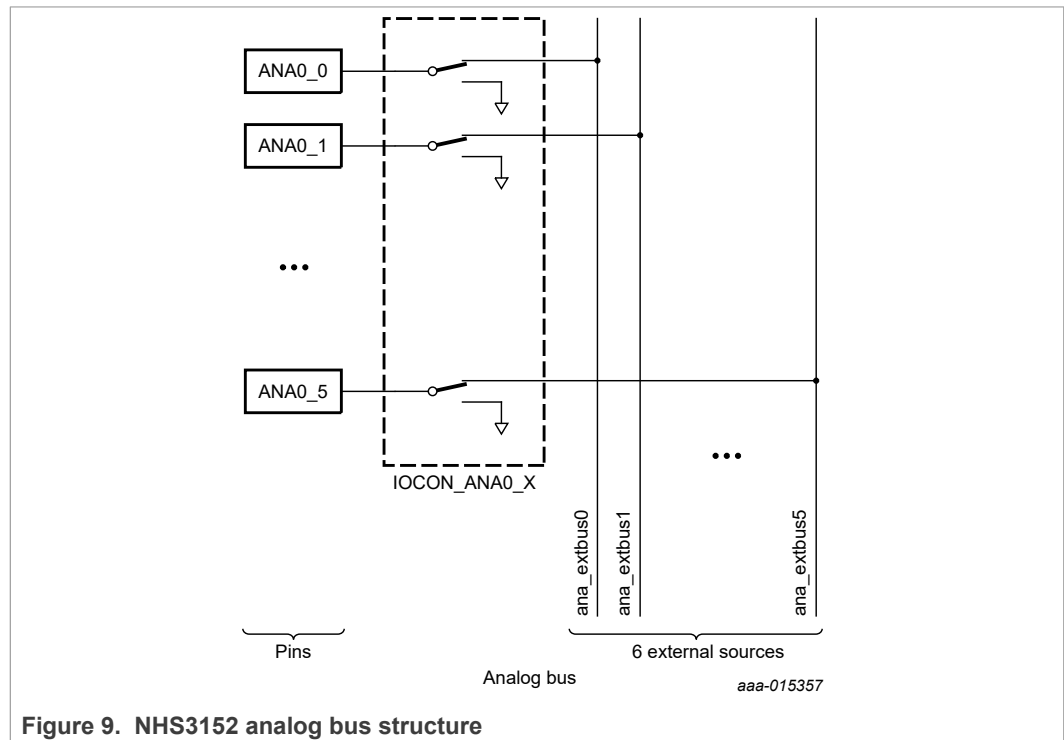

Figure 9. NHS3152 analog bus structure

8.7 I/O configuration

The I/O configuration registers control the electrical characteristics of the pads. The following features are programmable:

- Pin function
- Internal pull-up/pull-down resistor or bus keeper function
- Low-pass filter
- I²C-bus mode for pads hosting the I²C-bus function

The IOCON registers control the function (GPIO or peripheral function), the input mode, and the hysteresis of all PIO0_m pins. In addition, the I²C-bus pins can be configured for different I²C-bus modes.

The FUNC bits in the IOCON registers can be set to GPIO (FUNC = 000) or to a peripheral function. If the pins are GPIO pins, the GPIO0DIR registers determine whether the pin is configured as an input or output. For any peripheral function, the pin direction is controlled automatically depending on the functionality of the pin. The GPIO0DIR registers have no effect on peripheral functions.

8.7.1 PIO0 pin mode

The MODE bits in the IOCON register allow the selection of on-chip pull-up or pull-down resistors for each pin or to select the repeater mode. The possible on-chip resistor configurations are pull-up enabled, pull-down enabled, or no pull-up/pull-down. The default value is no pull-up or pull-down enabled. When the pin is at logic 1, the repeater mode enables the pull-up resistor. When the pin is at logic 0, it enables the pull-down resistor. If this pin is configured as an input and is not driven externally, this mode causes it to retain its last known state. The state retention is not applicable to the deep power-down mode. Repeater mode is typically used to prevent a pin from floating when it is not driven temporarily. Allowing it to float may use significant power.

8.7.2 PIO0 I²C-bus mode

If the FUNC bits of registers PIO0_4 and PIO0_5 select the I²C-bus function, the I²C-bus pins can be configured for different I²C-bus modes:

- Standard-mode/fast-mode I²C-bus with input glitch filter (including an open-drain output according to the I²C-bus specification)
- Standard open-drain I/O functionality without input filter

8.7.3 PIO0 current source mode

PIO0_3, PIO0_7, PIO0_10, and PIO0_11 are high-source pads that can deliver up to 20 mA to the load. These PIO pins can be set to either digital mode or analog current sink mode. In digital mode, the output voltage of the pad switches between VSS and VDD. In analog current drive mode, the output current sink switches between the values set by the ILO and IHI bits. The maximum pad voltage is limited to 5 V.

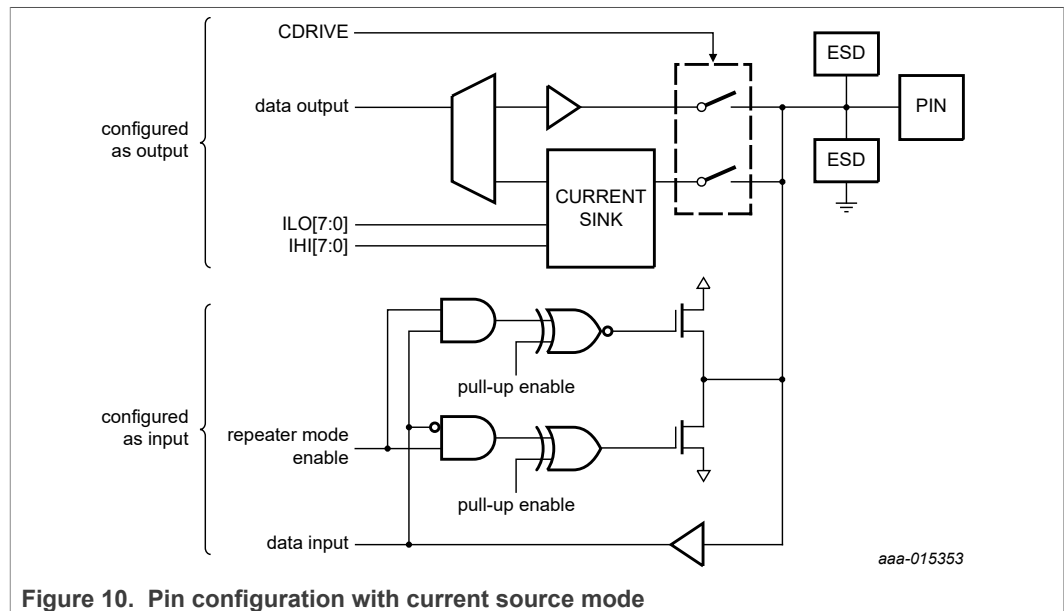

8.7.4 ANA0 input selection

The analog pins have direct analog connections to the internal analog bus and are protected by the ESD structures. The FUNC bit in the IOCON register determines the interconnections.

Each of these I/O pins can dynamically be connected to the on-chip converters:

- Analog-to-digital converter (ADC)
- Digital-to-analog converter (DAC)
- Current-to-digital converter (CDC)

Only one instance is implemented of each of these converters. As a consequence, to measure six voltages connected to the six analog I/O pins, time-division multiplexing must be used. Other combinations are also possible.

8.8 Fast general-purpose parallel I/O

The GPIO registers control device pins that are not connected to a specific peripheral function. Pins may be dynamically configured as inputs or outputs. Multiple outputs can be set or cleared in one write operation.

The NHS3152 uses accelerated GPIO functions:

- GPIO registers are on the Arm Cortex-M0+ I/O bus for fastest possible single-cycle I/O timing
- An entire port value can be written in one instruction
- Mask, set, and clear operations are supported for the entire port

All GPIO port pins are fixed-pin functions that are enabled or disabled on the pins by the switch matrix. So, each GPIO port pin is assigned to one specific pin and cannot be moved to another pin.

8.8.1 Features

- Bit-level port registers allow a single instruction to set and clear any number of bits in one write operation
- Direction control of individual bits
- After reset, all I/Os default to GPIO inputs without pull-up or pull-down resistors; The I²C-bus true open-drain pins PIO0_4 and PIO0_5 and the SWD pins PIO0_10 and PIO0_11 are exceptions
- Pull-up/pull-down configuration, repeater, and open-drain modes can be programmed through the IOCON block for each GPIO pin
- Direction (input/output) can be set and cleared individually per pin
- Pin direction bits can be toggled

8.9 I²C-bus controller

8.9.1 Features

Standard I²C-bus compliant ([Ref. 3](#)) interfaces may be configured as master, slave, or master/slave.

- Arbitration is handled between simultaneously transmitting masters without corruption of serial data on the bus
- Programmable clock allows adjustment of I²C-bus transfer rates
- Data transfer is bidirectional between masters and slaves
- Serial clock synchronization allows devices with different bit rates to communicate via one serial bus

- Serial clock synchronization is used as a handshake mechanism to suspend and resume serial transfer
- Supports standard mode (100 kbit/s) and fast mode (400 kbit/s)
- Optional recognition of up to four slave addresses
- Monitor mode allows observing all I²C-bus traffic, regardless of slave address
- The I²C-bus can be used for test and diagnostic purposes
- The I²C-bus contains a standard I²C-bus compliant interface with two pins
- Possibility to wake up NHS3152 on matching I²C-bus slave address

8.9.2 General description

Two types of data transfers are possible on the I²C-bus, depending on the state of the direction bit (R/W):

- Data transfer from a master transmitter to a slave receiver
The first byte transmitted by the master is the slave address. Next follows a number of data bytes. The slave returns an acknowledge bit after each received byte.
- Data transfer from a slave transmitter to a master receiver
The master transmits the first byte (the slave address). The slave then returns an acknowledge bit. The slave then transmits the data bytes to the master. The master returns an acknowledge bit after all received bytes other than the last byte. At the end of the last received byte, a not-acknowledge is returned. The master device generates all of the serial clock pulses and the START and STOP conditions. A transfer is ended with a STOP condition or with a repeated START condition. As a repeated START condition is also the beginning of the next serial transfer, the I²C-bus is not released.

The I²C-bus interface is byte oriented and has four operating modes:

- Master transmitter mode
- Master receiver mode
- Slave transmitter mode
- Slave receiver mode

The I²C-bus interface is completely I²C-bus compliant, supporting the ability to power off the NHS3152 independent of other devices on the same I²C-bus.

The I²C-bus interface requires a minimum 2 MHz system clock to operate in normal mode and 8 MHz for fast mode.

8.9.3 I²C-bus pin description

Table 11. I²C-bus pin description

Pin	Type	Description
SDA	I/O	I ² C-bus serial data
SCL	I/O	I ² C-bus serial clock

The I²C-bus pins must be configured through the PIO0_4 and PIO0_5 registers for standard mode or fast mode. The I²C-bus pins are open-drain outputs and fully compatible with the I²C-bus specification.

8.10 SPI controller

8.10.1 Features

- Compatible with Motorola SPI, 4-wire Texas Instruments Synchronous Serial Interface (SSI), and National Semiconductor Microwire buses
- Synchronous Serial Communication
- Supports master or slave operation
- Eight-frame FIFOs for both transmit and receive
- 4-bit to 16-bit frame

8.10.2 General description

The SPI/SSP is a Synchronous Serial Port (SSP) controller capable of operation on an SPI, 4-wire SSI, or Microwire bus. It can interact with multiple masters and slaves on the bus. Only a single master and a single slave can communicate on the bus during a given data transfer. Data transfers are in principle full duplex, with frames from 4 bits to 16 bits of bidirectional data flowing between master and slave. In practice, often only one of these two data flows carries meaningful data.

8.10.3 Pin description

Table 12. SPI pin description

Pin name	Type	Interface pin SPI	SSI	Microwire	Description
SCLK	I/O	SCLK	CLK	SK	serial clock
SSEL	I/O	SSEL	FS	CS	frame sync/slave select
MISO	I/O	MISO	DR (M) DX (S)	SI (M) SO (S)	master input slave output
MOSI	I/O	MOSI	DX (M) DR (S)	SO (M) SI (S)	master output slave input

8.10.3.1 Pin detailed description

Serial clock

SCK/CLK/SK is a clock signal used to synchronize the transfer of data. The master drives the clock signal and the slave receives it. When SPI/SSP interface is used, the clock is programmable to be active HIGH or active LOW, otherwise it is always active HIGH. SCK only switches during a data transfer. At any other time, the SPI/SSP interface either stays in its inactive state or is not driven (remains in high-impedance state).

Frame sync/slave select

When the SPI/SSP interface is a bus master, it drives this signal to an active state before the start of serial data. It then releases it to an inactive state after the data has been sent. The active state can be HIGH or LOW depending upon the selected bus and mode. When the SPI/SSP interface is a bus slave, this signal qualifies the presence of data from the master according to the protocol in use.

When there is only one master and slave, the master signals, frame sync, or slave select, can be connected directly to the corresponding slave input. When there are multiple

slaves, further qualification of frame sync/slave select inputs is normally necessary to prevent more than one slave from responding to a transfer.

Master Input Slave Output (MISO)

The MISO signal transfers serial data from the slave to the master. When the SPI/SSP is a slave, it outputs serial data on this signal. When the SPI/SSP is a master, it clocks in serial data from this signal. It does not drive this signal and leaves it in a high-impedance state when the SPI/SSP is a slave and not selected by FS/SSEL.

Master Output Slave Input (MOSI)

The MOSI signal transfers serial data from the master to the slave. When the SPI/SSP is a master, it outputs serial data on this signal. When the SPI/SSP is a slave, it clocks in serial data from this signal.

8.11 RFID/NFC communication unit

8.11.1 Features

- ISO/IEC14443A part 1 to part 3 compatible
- MIFARE (Ultralight) EV1 compatible
- NFC Forum Type 2 compatible
- Easy interfacing with standard user memory space READ/WRITE commands
- Passive operation possible

8.11.2 General description

The RFID/NFC interface allows communication using 13.56 MHz proximity signaling.

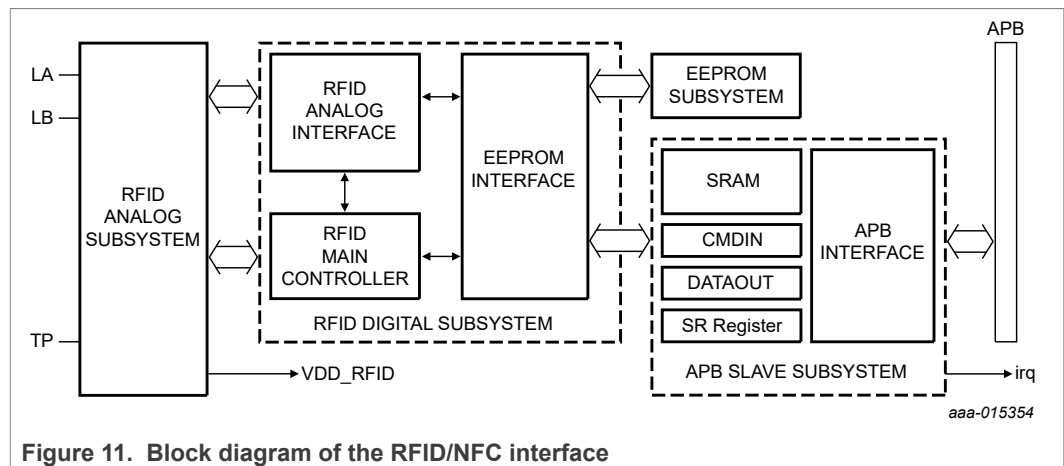

Figure 11. Block diagram of the RFID/NFC interface

The CMDIN, DATAOUT, status register (SR), and SRAM are mapped in the user memory space of the RFID core. The RFID READ and WRITE commands allow wireless communication to this shared memory.

Messages can be in raw mode (user proprietary protocol) or formatted according to NFC Forum Type 2 NDEF messaging and ISO/IEC 11073.

8.12 16-bit timer

8.12.1 Features

One 16-bit timer with a programmable 16-bit prescaler.

- Timer operation
- Four 16-bit match registers that allow:
 - Continuous operation with optional interrupt generation on match
 - Stop timer on match with optional interrupt generation
 - Reset timer on match with optional interrupt generation
- Up to two CT16B external outputs corresponding to the match registers with the following capabilities:
 - Set LOW on match
 - Set HIGH on match
 - Toggle on match
 - Do nothing on match
- Up to two match registers can be configured as pulse width modulation (PWM). It allows the use of up to two match outputs as single edge controlled PWM outputs

8.12.2 General description

The peripheral clock (PCLK), which is derived from the system clock, clocks the timer. The timer can generate interrupts or perform other actions at specified timer values based on four match registers. The system clock provides the peripheral clock.

Each timer also includes one capture input to trap the timer value when an input signal transitions, optionally generating an interrupt.

In PWM mode, four match registers can be used to provide a single-edge controlled PWM output on the match output pins. The use of the match registers that are not pinned out to control the PWM cycle length is recommended.

8.13 32-bit timer

8.13.1 Features

One 32-bit timer with a programmable 32-bit prescaler.

- Timer operation
- Four 32-bit match registers that allow:
 - Continuous operation with optional interrupt generation on match
 - Stop timer on match with optional interrupt generation
 - Reset timer on match with optional interrupt generation
- Up to two CT32B external outputs corresponding to the match registers with the following capabilities:
 - Set LOW on match
 - Set HIGH on match
 - Toggle on match
 - Do nothing on match
- Up to two match registers can be configured as PWM allowing the use of up to two match outputs as single edge controlled PWM outputs

8.13.2 General description

The peripheral clock (PCLK), which is derived from the system clock, clocks the timer. The timer can generate interrupts or perform other actions at specified timer values based on four match registers. The system clock provides the peripheral clock.

Each timer also includes one capture input to trap the timer value when an input signal transitions, optionally generating an interrupt.

In PWM mode, four match registers can be used to provide a single-edge controlled PWM output on the match output pins. Use of the match registers that are not pinned out to control the PWM cycle length is recommended.

8.14 Watchdog Timer (WDT)

If the microcontroller enters an erroneous state, the purpose of the Watchdog Timer (WDT) is to reset it within a reasonable amount of time.

When enabled, if the user program fails to feed (or reload) the WDT within a predetermined amount of time, the WDT generates a system reset.

8.14.1 Features

- If not periodically reloaded, it internally resets the microcontroller
- Debug mode
- Enabled by software but requires a hardware reset or a WDT reset/interrupt to be disabled
- If enabled, an incorrect/incomplete feed sequence causes reset/interrupt
- Flag to indicate WDT reset
- Programmable 24-bit timer with internal prescaler
- Selectable time period from $(\text{TWDCCLK} \times 256 \times 4)$ to $(\text{TWDCCLK} \times 2^{24} \times 4)$ in multiples of $\text{TWDCCLK} \times 4$
- The WDT clock (WDCLK) source is a 2 MHz clock derived from the SFRO or the external clock as set by the SYSCLKCTRL register

8.14.2 General description

The WDT consists of a divide by 4 fixed prescaler and a 24-bit counter. The clock is fed to the timer via a prescaler. When clocked, the timer decrements. The minimum value by which the counter is decremented is 0xFF. Setting a value lower than 0xFF causes 0xFF to be loaded in the counter. Hence the minimum WDT interval is $(\text{TWDCCLK} \times 256 \times 4)$ and the maximum is $(\text{TWDCCLK} \times 2^{24} \times 4)$, in multiples of $(\text{TWDCCLK} \times 4)$.

8.15 System tick timer

8.15.1 Features

- Simple 24-bit timer
- Uses dedicated exception vector
- Clocked internally by the system clock or the system clock divided by two

8.15.2 General description

The SYSTICK timer is a part of the Cortex-M0+. The SYSTICK timer can be used to generate a fixed periodic interrupt for use by an operating system or another system. Since the SYSTICK timer is a part of the Cortex-M0+, it facilitates porting of software by providing a standard timer available on Cortex-M0+ based devices. The SYSTICK timer can be used for management software.

Refer to the Cortex-M0+ Devices - Generic User Guide ([Ref. 2](#)) for details.

8.16 Real-Time Clock (RTC) timer

8.16.1 Features

The real-time clock (RTC) block contains two counters:

- A countdown timer generating a wake-up signal when it expires
- A continuous counter that counts seconds since power-up or the last system reset

The countdown timer runs on a low-speed clock and runs in an always-on power domain. The delay, as well as a clock tuning prescaler, can be configured via the APB bus. The RTC countdown timer generates the deep power-down wake-up signal and the RTC interrupt signal (wake-up interrupt 12). The deep power-down wake-up signal is always generated, while the interrupt can be masked according to the settings in the RTCIMSC register.

8.16.2 General description

The RTC module consists of two parts:

- The RTC core module, implementing the RTC timers themselves. This module runs in the always-on VDD_ALON domain.
- The AMBA APB slave interface. This module allows the configuration of the RTC core via an APB bus. This module runs in the switched power domain.

8.17 Temperature sensor

8.17.1 Features

The temperature sensor block measures the chip temperature and outputs a raw value or a calibrated value in Kelvin.

8.17.2 General description

The temperature is measured using a high-precision, zoom-ADC. The analog part is able to measure a highly temperature-dependent $X = V_{be} / \Delta V_{be}$ ¹. It determines the value of X by first applying a coarse search (successive approximation), and then a sigma-delta in a limited range. The conversion time depends on the resolution mode as shown below.

Table 13. Conversion time for different resolution of TSENS

Resolution (bit)	Resolution (°C)	Conversion time (ms)
7	±0.8	4
8	±0.4	7
9	±0.2	14
10	±0.1	26
11	±0.05	50
12	±0.025	100

¹ V_{be} is the base-emitter voltage of a bipolar transistor. Basically, the temperature sensor measures the voltage drop over a diode formed by the base-emitter junction of a bipolar transistor. It compares the V_{be} at different current levels (from which follows the ΔV_{be}).

8.18 Current-to-Digital converter (I2D)

8.18.1 General description

The current-to-digital (I2D) converter is based on a 16-bit I/F converter with selectable integration time. The input signal is selected from any analog input bus via an input multiplexer and passes through an input scaler circuit.

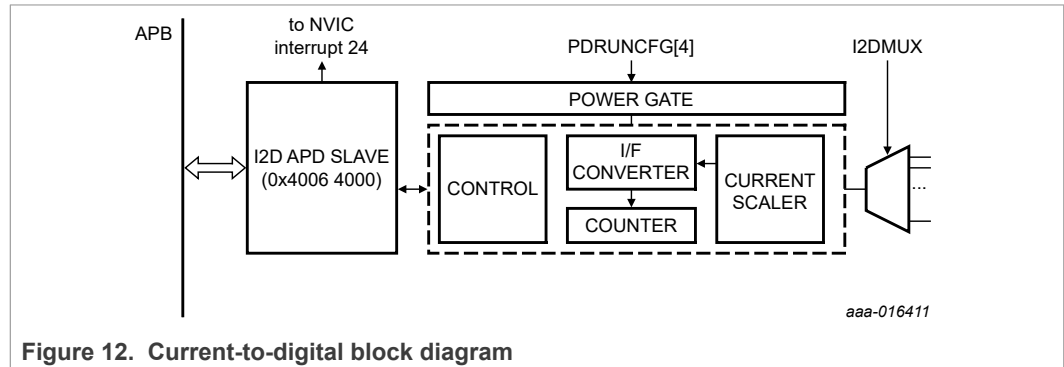

Figure 12. Current-to-digital block diagram

8.18.2 Specifications

Table 14. Minimum input voltage

Symbol	Parameter	Conditions	Min	Typ	Max	Unit
$V_{i(min)}$	minimum input voltage	current scaler	-	500	-	mV

Table 15 shows the range and resolution for all the valid input gain and internal gain settings of the current-to-digital converter.

The 'Bias' column indicates that the I2D is biasing the bus. The 'Source/sink' column indicates whether the I2D is sourcing or sinking current.

Table 15. Range and resolution settings for 200 ms integration time

Scaler gain	Bias	Source/sink	ADC gain	I2D_GAIN	Input min ^[1]	Input max	Res.
1:1	-	sink	low	000b	228 pA	2.5 μ A	38 pA
10:1	-	sink	low	100b	6.1 nA	25 μ A	381 pA
100:1	-	sink	low	101b	74 nA	250 μ A	381 nA
bypass	1.1 V	source	low	-	30 pA	2.5 μ A	38 pA

[1] Minimum current input to achieve ENOB

The input of the I/F converter is biased at 1.1 V. If the current scaler is enabled, this bias voltage is not seen at the input multiplexer.

Shorter integration times (such as 20 ms or 16 ms) reduce the maximum resolution as indicated in Table 16.

Table 16. Resolution and maximum input current as a function of integration time, for 1:1 or bypass mode

Integration time	Sampling rate	Resolution (bits) ^[1]	Max current in, avoiding saturation
			ADC gain 1
10 ms	100 Hz	9.0	2.5 μ A
16 ms	62.5 Hz	12.3	2.5 μ A
20 ms	50 Hz	13.0	2.5 μ A
100 ms	10 Hz	15.6	2.5 μ A
200 ms	5 Hz	16.0	1.64 μ A
400 ms	1.25 Hz	16.0	819 nA

[1] Note: resolution means digital output resolution, not the effective number of bits (ENOB)

8.18.3 Input multiplexer

The input to the current-to-digital converter is connected to the analog buses via an analog multiplexer. [Table 17](#) provides an overview of the inputs of the multiplexer.

Table 17. Connections to the current-to-digital analog input multiplexer.

AMUX input	Source	Description
0	ana_extbus0	(external) pin ANA0_0
1	ana_extbus1	(external) pin ANA0_1
2	ana_extbus2	(external) pin ANA0_2
3	ana_extbus3	(external) pin ANA0_3
4	ana_extbus4	(external) pin ANA0_4
5	ana_extbus5	(external) pin ANA0_5

8.19 Analog-to-Digital Converter/Digital-to-Analog Converter 0 (ADCDAC0)

8.19.1 Features

- 12-bit ADC operation at 80 kSa/s
- 12-bit DAC operation with hold amplifier

8.19.2 General description

The ADCDAC0 peripheral is based on a 12-bit successive-approximation charge-redistribution analog-to-digital converter. The peripheral acts as either an analog-to-digital converter or a digital-to-analog converter, depending on which start bit is written to the control register CR. Requests are handled in round-robin fashion.

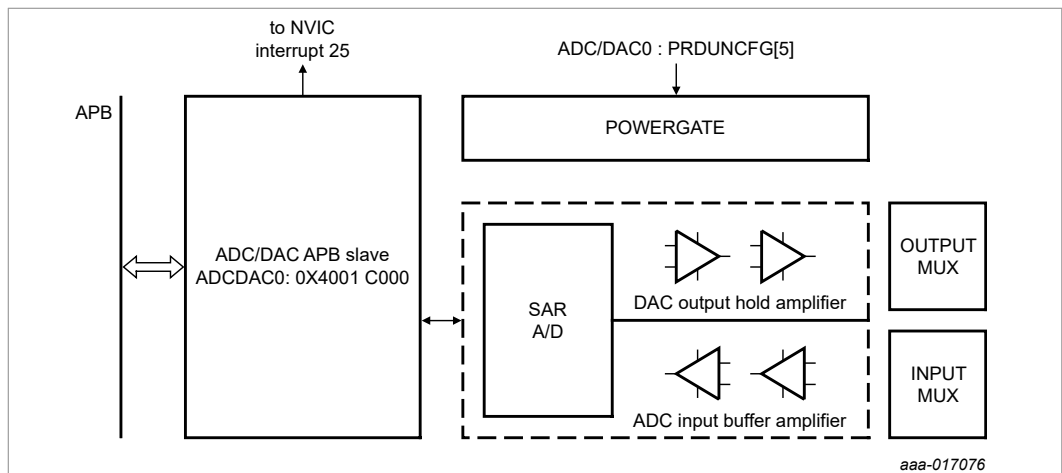

Figure 13. Analog-to-digital/digital-to-analog block diagram

8.19.3 Input multiplexer and output switch matrix

The ADC input and DAC output are connected to the analog buses via an analog multiplexer. [Table 18](#) shows the connections of the multiplexer.

Table 18. Connections to ADC input multiplexer and DAC output switch

AMUX input	Source	Description
0	ana_extbus0	(external) pin ANA0_0
1	ana_extbus1	(external) pin ANA0_1
2	ana_extbus2	(external) pin ANA0_2
3	ana_extbus3	(external) pin ANA0_3
4	ana_extbus4	(external) pin ANA0_4
5	ana_extbus5	(external) pin ANA0_5

8.20 Using NHS3152 to measure resistance

8.20.1 Measurement principle

The two terminals of the device-under-test (DUT) can be connected to any of the external analog input pins. The routing of input pins to the ADC/DAC and I2D are done by configuring the input multiplexer registers of the ADC/DAC and I2D.

Configure the ADC/DAC and I2D as shown in [Figure 14](#).

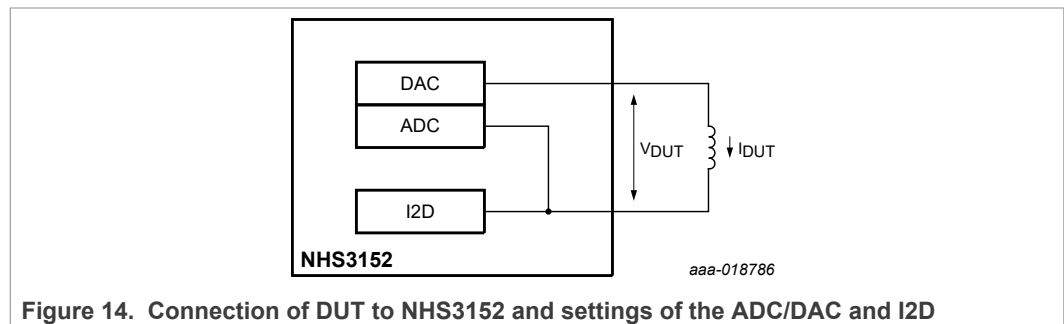

Figure 14. Connection of DUT to NHS3152 and settings of the ADC/DAC and I2D

Apply the desired bias voltage to the first terminal (preferably as high as possible), and sequentially measure the voltage and current on the second terminal. The resistance is found by dividing the measured voltage drop with the measured current through the DUT.

The effective measurement resolution of the resistance value depends on the selected input range of the I2D. For high currents (low-resistance values) relative to the range settings, the ADC/DAC limits the resolution. For high resistances (low currents), the I2D is limiting. [Table 19](#) gives different recommended combinations.

Table 19. Resolution of resistance measurement in different ranges

I2D range	Recommended R_{min}	Recommended R_{max}	Resolution at R_{max} (bit)	Resolution at R_{max}	Resolution at R_{min} (bit)	Resolution at R_{min}
2.5 μ A	40 k Ω	7 M Ω	6.2	95 k Ω	8.9	83.7 Ω
25 μ A	4 k Ω	1.4 M Ω	5.5	31 k Ω	8.9	8.4 Ω
250 μ A	400 Ω	140 k Ω	5.0	4.38 k Ω	8.9	0.83 Ω

8.21 Serial Wire Debug (SWD)

The debug functions are integrated into the ARM Cortex-M0+. Serial Wire Debug (SWD) functions are supported. The ARM Cortex-M0+ is configured to support up to four breakpoints and two watchpoints.

- Supports ARM SWD mode
- Direct debug access to all memories, registers, and peripherals
- No target resources are required for the debugging session
- Four breakpoints
 - Four instruction breakpoints that can also be used to remap instruction addresses for code patches. Two data comparators that can be used to remap addresses for patches to literal values.
- Two data watchpoints that can also be used as triggers

8.22 On-chip flash memory

The NHS3152 contains a 32 kB flash memory of which 30 kB can be used as program and data memory.

The flash is organized in 32 sectors of 1 kB. Each sector consists of 16 rows of 16 × 32-bit words.

8.22.1 Reading from flash

Reading is done via the AHB interface. The memory is mapped on the bus address space as a contiguous address space. Memory data words are seen on the bus using a little endian arrangement.

8.22.2 Writing to flash

Writing to flash means copying a word of data over the AHB to the page buffer of the flash. It does not actually program the data in the memory array. This programming is done by subsequent erase and program cycles.

8.22.3 Erasing/programming flash

Erasing and programming are separate operations. Both are possible only on memory sectors that are unprotected and unlocked. Protect/lock information is stored inside the memory itself, so the controller is not aware of protection status. Therefore, if a program/erase operation is performed on a protected or locked sector, it does not flag an error.

Protection

At exit from reset, all sectors are protected against accidental modification. To allow modification, a sector must be unprotected. It can then be protected again after that the modification is performed.

Locking

Each flash sector has a lock bit. Lock bits can be set but cannot be cleared. Locked sectors cannot be erased and reprogrammed.

8.23 On-chip SRAM

The NHS3152 contains a total of 8 kB on-chip SRAM memory configured as 256 × 2 × 4 × 32 bit.

8.24 On-chip EEPROM

The NHS3152 contains a 4 kB EEPROM. This EEPROM is organized in 64 rows of 32 × 16-bit words. Of these rows, the last four contain calibration and test data and are locked. This data is either used by the boot loader after reset, or made accessible to the application via firmware Application Programming Interface (API).

8.24.1 Reading from EEPROM

Reading is done via the AHB interface. The memory is mapped on the bus address space, as a contiguous address space. Memory data words are seen on the bus using a little endian arrangement.

8.24.2 Writing to EEPROM

Erasing and programming is performed, as a single operation, on one or more words inside a single page.

Previous write operations have transferred the data to be programmed into the memory page buffer. The page buffer tracks which words were written to (offset within the page only). Words not written to, retain their previous content.

9 Limiting values

Table 20. Limiting values

In accordance with the Absolute Maximum Rating System (IEC 60134).

Symbol	Parameter	Conditions	Min	Max	Unit
V_{DD}	supply voltage		-0.5	+3.6	V
V_I	input voltage	normal PIO pads ($V_{DD} = 0.6$ V)	-0.5	+3.6	V
		high-source PIO pads	-0.5	+5.5	V
		LA/LB pads	-0.5	+5.5	V
I_{DD}	supply current	per supply pin	-	100	mA
I_{SS}	ground supply current	per supply pin	-	100	mA
I_{lu}	latch-up current	I/O; $-0.5V_{DD} < V_I < +1.5V_{DD}$; $T_j < 125$ °C	-	100	mA
T_{stg}	storage temperature		-40	+125	°C
T_j	junction temperature		-	125	°C
P_{tot}	total power dissipation		-	1	W
V_{ESD}	electrostatic discharge voltage	human body model; all pins	-2000	+2000	V
		charged device model; all pins	-500	+500	V

10 Static characteristics

Table 21. Static characteristics

$T_{amb} = -40\text{ }^{\circ}\text{C}$ to $+85\text{ }^{\circ}\text{C}$, unless otherwise stated.

Symbol	Parameter	Conditions	Min	Typ	Max	Unit
Supply pins						
V_{DD}	supply voltage		1.72	3.0	3.60	V
I_{DD}	supply current	voltage and clock frequency dependent ^[1]	-	-	-	μA
$I_{L(off)}$	off-state leakage current		-	-	50	nA
$I_{DD(pd)}$	power-down mode supply current	deep power-down mode	-	3	-	μA
Standard GPIO pins						
V_{IH}	HIGH-level input voltage		$0.7V_{dd}$	-	-	V
V_{IL}	LOW-level input voltage		-	-	$0.3V_{dd}$	V
V_{hys}	hysteresis voltage		0.4	-	-	V
R_{pd}	pull-down resistance		-	72	-	k Ω
R_{pu}	pull-up resistance		-	73	-	k Ω
I_S	source current	HIGH-level $V_{DD} = 1.8\text{ V}$ ^[2]	-	2	-	mA
		HIGH-level $V_{DD} = 3.6\text{ V}$ ^[2]	-	8	-	mA
		LOW-level $V_{DD} = 1.8\text{ V}$ ^[2]	-	4	-	mA
		LOW-level $V_{DD} = 3.6\text{ V}$ ^[2]	-	16	-	mA
High-drive GPIO pins						
I_S	source current	HIGH-level $V_{DD} = 1.8\text{ V}$ ^[3]	4	-	6	mA
		HIGH-level $V_{DD} = 3.6\text{ V}$ ^[3]	13	-	18	mA
		LOW-level $V_{DD} = 1.8\text{ V}$ ^[3]	5.5	-	8	mA
		LOW-level $V_{DD} = 3.6\text{ V}$ ^[3]	22	-	32	mA
I²C-bus pins						
I_S	source current	LOW-level $V_{DD} = 1.8\text{ V}$ ^[4]	2	-	8.5	mA
		LOW-level $V_{DD} = 3.6\text{ V}$ ^[4]	9.5	-	38	mA
Brownout detect						
$V_{trip(bo)}$	brownout trip voltage	falling V_{DD}	-	1.8	-	V
		rising V_{DD}	-	1.875	-	V
V_{hys}	hysteresis voltage		-	75	-	mV
General						
$R_{pu(int)}$	internal pull-up resistance	on pin RESETN	-	100	-	k Ω
C_{ext}	external capacitance	on pin RESETN	-	-	1	nF

[1] See [Figure 15](#)

[2] PIO0_0, PIO0_1, PIO0_2, PIO0_6, PIO0_8, PIO0_9

[3] PIO0_3, PIO0_7, PIO0_10, PIO0_11

[4] PIO0_4, PIO0_5

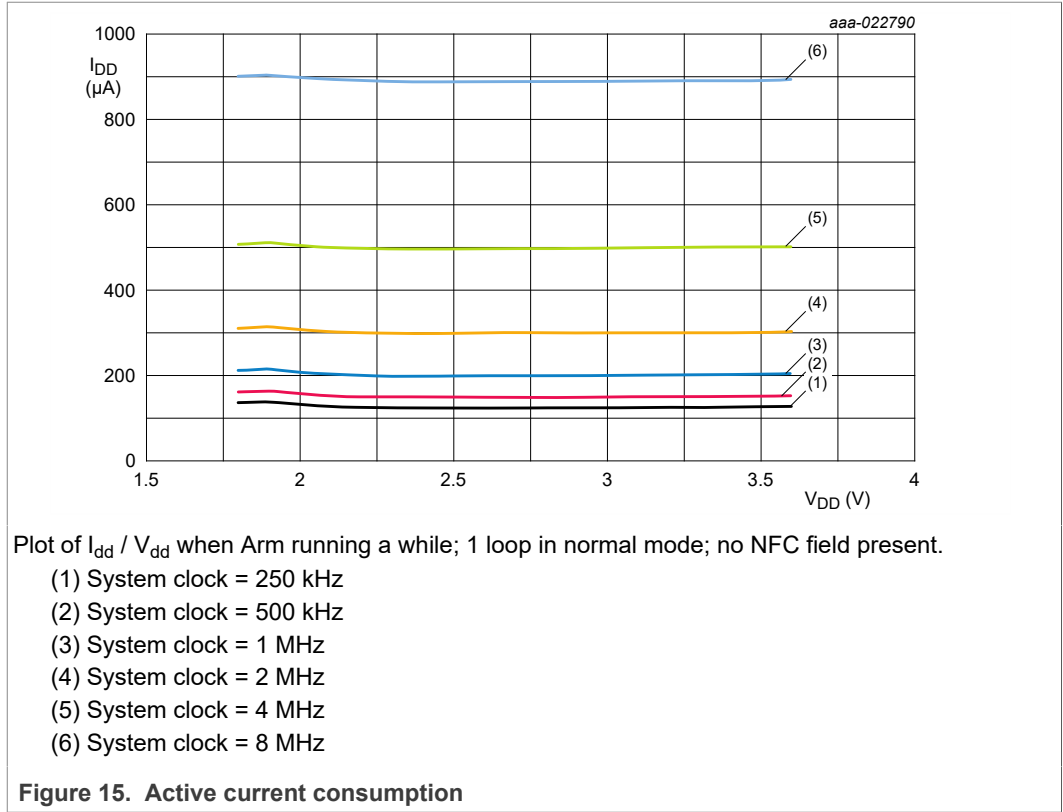

Table 22. Temperature sensor characteristics

Symbol	Parameter	Conditions	Min	Typ	Max	Unit
$I_{CC(pd)}$	power-down mode supply current	TSEN disabled	-	-	1	nA
I_{stb}	standby current	TSEN enabled	-	6	7	μ A
$I_{CC(oper)}$	operating supply current	TSEN converting	-	10	12	μ A
T_{acc}	temperature accuracy	$T_{amb} = 0\text{ }^{\circ}\text{C to }+45\text{ }^{\circ}\text{C}$	-0.3	-	+0.3	$^{\circ}\text{C}$
		$T_{amb} = -40\text{ }^{\circ}\text{C to }+85\text{ }^{\circ}\text{C}$	-0.5	-	+0.5	$^{\circ}\text{C}$
T_{res}	temperature resolution	12-bit mode	-	0.025	-	$^{\circ}\text{C}$
		8-bit mode	-	0.4	-	$^{\circ}\text{C}$
T_{conv}	conversion period	12-bit mode	-	100	-	ms
		8-bit mode	-	7	-	ms

Note:

All ICs are individually temperature-calibrated in production and ISO/IEC 17025 calibration certificates with NIST traceability are available at nxp.com/NTAGSMARTSENSOR.

The absolute accuracy is valid for the factory calibration of the temperature sensor. The sensor can be user-calibrated to reach higher accuracy.

Table 23. Current-to-digital converter specifications

Symbol	Parameter	Conditions	Min	Typ	Max	Unit
$I_{DD(pd)}$	power-down mode supply current	I2D disabled	-	-	1	nA
I_{stb}	standby current	I2D enabled	-	6	7	μ A
$I_{DD(oper)}$	operating supply current	I2D converting	-	94	-	μ A
$I_{meas(res)}$	current measurement resolution	at 200 ms integration time				
		input gain 1:1	-	38	-	pA
		input gain 100:1	-	3.8	-	nA
$V_{i(min)}$	minimum input voltage	current scaler	-	500	-	mV
ENOB	effective number of bits	at 200 ms integration time (after calibration)				
		low gain bypass	-	14.5	-	bit
		low gain 1:1	-	12.8	-	bit
		low gain 10:1	-	14.4	-	bit
		low gain 100:1	-	14.0	-	bit
I_{offset}	offset current	at 25 °C	-	3	-	nA
		at 85 °C	-	30	-	nA

Table 24. ADC specifications

Symbol	Parameter	Conditions	Min	Typ	Max	Unit
General						
$I_{DD(act)}$	active mode supply current	average	-	60	-	μ A
t_{conv}	conversion time		-	12	-	μ s
C_{in}	input capacitance		-	-	12	pF
R_i	input resistance		4	-	-	M Ω
Range = 1.6 V						
V_{IA}	analog input voltage		0.108	-	1.744	V
G	gain		-	2.5	-	LSB/mV
E_G	gain error	[1]	-	-	100	LSB
$V_{n(i)}$	input noise voltage		-	50	-	LSB
Range = 1.0 V						
V_{IA}	analog input voltage		0.060	-	0.969	V
G	gain		-	4.5	-	LSB/mV
E_G	gain error	[1]	-	-	30	LSB
$V_{n(i)}$	input noise voltage		-	11	-	LSB

[1] Max deviation from a straight line between $V_{in,min}$ and $V_{in,max}$

Table 25. DAC specifications

Symbol	Parameter	Conditions	Min	Typ	Max	Unit
General						
$I_{DD(Act)}$	active mode supply current	excluding external drive. $R_{load} = 10\text{ M}\Omega$	-	145	-	μA
I_{source}	source current		-	-	1	mA
t_{conv}	conversion time		-	25	-	μs
C_L	load capacitance		-	-	250	pF
R_L	load resistance		1	-	-	k Ω
R_o	output resistance	of DAC	-	1	-	Ω
V_{oa}	analog output voltage	$R_{load} = 47\text{ k}\Omega$	0.275	-	1.59	V
ENOB	effective number of bits	$R_{load} = 47\text{ k}\Omega$	-	9.3	-	bit
INL	integral non-linearity		-	6.5	30	LSB
DNL	differential non-linearity		-	7.3	-	LSB

Table 26. Antenna input characteristics

Symbol	Parameter	Conditions	Min	Typ	Max	Unit
C_i	input capacitance	[1]	-	50	-	pF
f_i	input frequency		-	13.56	-	MHz

[1] $T_{amb} = 22\text{ }^\circ\text{C}$, $f = 13.56\text{ MHz}$, RMS voltage between LA and LB = 1.5 V

Table 27. EEPROM characteristics

Symbol	Parameter	Conditions	Min	Typ	Max	Unit
$t_{ret(data)}$	data retention time	$T_{amb} = 22\text{ }^\circ\text{C}$	10	-	-	year

11 Dynamic characteristics

11.1 I/O pins

Table 28. I/O dynamic characteristics

These characteristics apply to standard port pins and RESETN pin.

$T_{amb} = -40\text{ °C to }+85\text{ °C}$.

Symbol	Parameter	Conditions	Min	Typ	Max	Unit
t_r	rise time	pin configured as output	3.0	-	5.0	ns
t_f	fall time	pin configured as output	2.5	-	5.0	ns

11.2 I²C-bus

Table 29. I²C-bus dynamic characteristics

See UM10204 - I²C-bus specification and user manual (Ref. 3) for details. $T_{amb} = -40\text{ °C to }+85\text{ °C}^{[1]}$; see the timing diagram in Figure 16.

Symbol	Parameter	Conditions	Min	Typ	Max	Unit
f_{SCL}	SCL clock frequency	Standard mode	0	-	100	kHz
		Fast mode	0	-	400	kHz
t_f	fall time of both SDA and SCL signals	Standard mode [2] [3] [4]	-	-	300	ns
		Fast mode [2] [3] [4]	$20 + 0.1 \times C_b$	-	300	ns
t_{LOW}	LOW period of the SCL clock	Standard mode	4.7	-	-	μ s
		Fast mode	1.3	-	-	μ s
t_{HIGH}	HIGH period of the SCL clock	Standard mode	4.0	-	-	μ s
		Fast mode	0.6	-	-	μ s
$t_{HD;DAT}$	data hold time	Standard mode [2] [5] [6]	0	-	-	μ s
		Fast mode [2] [5] [6]	0	-	-	μ s
$t_{SU;DAT}$	data setup time	Standard mode [7] [8]	250	-	-	ns
		Fast mode [7] [8]	100	-	-	ns

[1] Parameters are valid over operating temperature range unless otherwise specified.

[2] A device must internally provide a hold time of at least 300 ns for the SDA signal (regarding the $V_{IH(min)}$ of the SCL signal). The hold time is to bridge the undefined region of the falling edge of SCL.

[3] C_b = total capacitance of one bus line in pF.

[4] The maximum t_f for the SDA and SCL bus lines is specified at 300 ns. The maximum fall time for the SDA output stage t_f is specified at 250 ns. It allows series protection resistors to be connected between the SDA and the SCL pins and the SDA/SCL bus lines without exceeding the maximum specified t_f .

[5] $t_{HD;DAT}$ is the data hold time that is measured from the falling edge of SCL; applies to data in transmission and the acknowledge.

[6] The maximum $t_{HD;DAT}$ could be 3.45 μ s and 0.9 μ s for standard mode and fast mode. However, it must be less than the maximum of $t_{VD;DAT}$ or $t_{VD;ACK}$ by a transition time (see Ref. 3). Only meet this maximum if the device does not stretch the LOW period (t_{LOW}) of the SCL signal. If the clock stretches the SCL, the data must be valid by the setup time before it releases the clock.

[7] $t_{SU;DAT}$ is the data setup time that is measured against the rising edge of SCL; applies to data in transmission and the acknowledge.

[8] A fast-mode I²C-bus device can be used in a standard-mode I²C-bus system but it must meet the requirement $t_{SU;DAT} = 250$ ns. This requirement is automatically the case if the device does not stretch the LOW period of the SCL signal. If it does, it must output the next data bit to the SDA line $t_{f(max)} + t_{SU;DAT} = 1000 + 250 = 1250$ ns before the SCL line is released. This procedure is in accordance with the Standard-mode I²C-bus specification. Also, the acknowledge timing must meet this setup time.

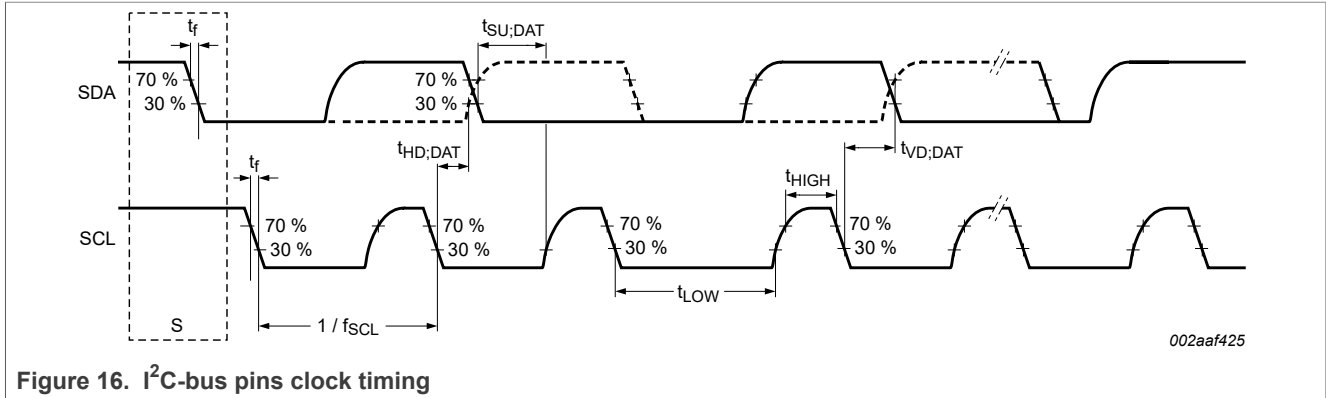

Figure 16. I²C-bus pins clock timing

11.3 SPI interfaces

Table 30. Dynamic characteristics of SPI pins in SPI mode

Symbol	Parameter	Conditions	Min	Typ	Max	Unit
SPI master						
t _{cy(clk)}	clock cycle time	full-duplex mode [1]	50	-	-	ns
		when only transmitting [1]	40	-	-	ns
t _{SU:DAT}	data setup time	2.4 V ≤ V _{DD} < 3.6 V [2]	15	-	-	ns
		2.0 V ≤ V _{DD} < 2.4 V [2]	20	-	-	ns
		1.8 V ≤ V _{DD} < 2.0 V [2]	24	-	-	ns
t _{HD:DAT}	data hold time	[2]	0	-	-	ns
t _{v(Q)}	data output valid time	[2]	-	-	10	ns
t _{h(Q)}	data output hold time	[2]	0	-	-	ns
SPI slave						
T _{cy(PCLK)}	PCLK cycle time	[3] [4]	0	-	-	ns
t _{HD:DAT}	data hold time	[3] [4]	3 × T _{cy(PCLK)} + 4	-	-	ns
t _{v(Q)}	data output valid time	[3] [4]	-	-	3 × T _{cy(PCLK)} + 11	ns
t _{h(Q)}	data output hold time	[3] [4]	-	-	2 × T _{cy(PCLK)} + 5	ns

[1] t_{cy(clk)} = (SSPCLKDIV × (1 + SCR) × CPSDVSR) / f_{main}. The clock cycle time derived from the SPI bit rate t_{cy(clk)} is a function of:

- The main clock frequency f_{main}
- The SPI peripheral clock divider (SSPCLKDIV)
- The SPI SCR parameter (specified in the SSP0CR0 register)
- The SPI CPSDVSR parameter (specified in the SPI clock prescale register)

[2] T_{amb} = -40 °C to +105 °C

[3] t_{cy(clk)} = 12 × T_{cy(PCLK)}

[4] T_{amb} = 25 °C for normal voltage supply: V_{DD} = 3.3 V

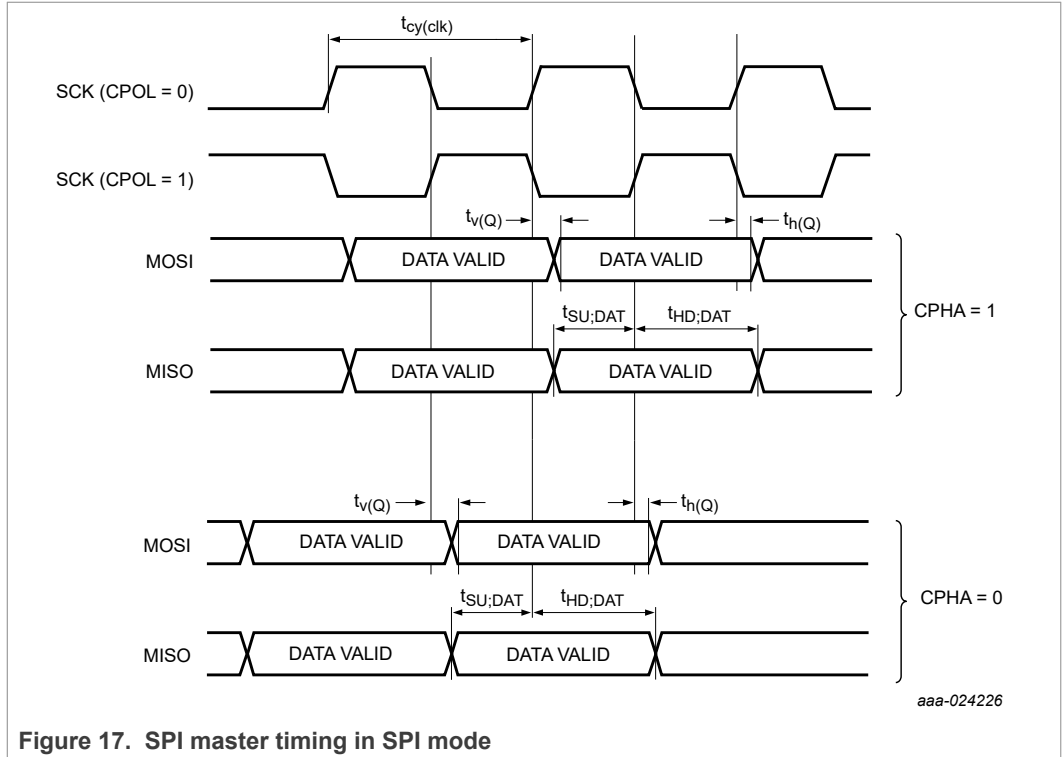

Figure 17. SPI master timing in SPI mode

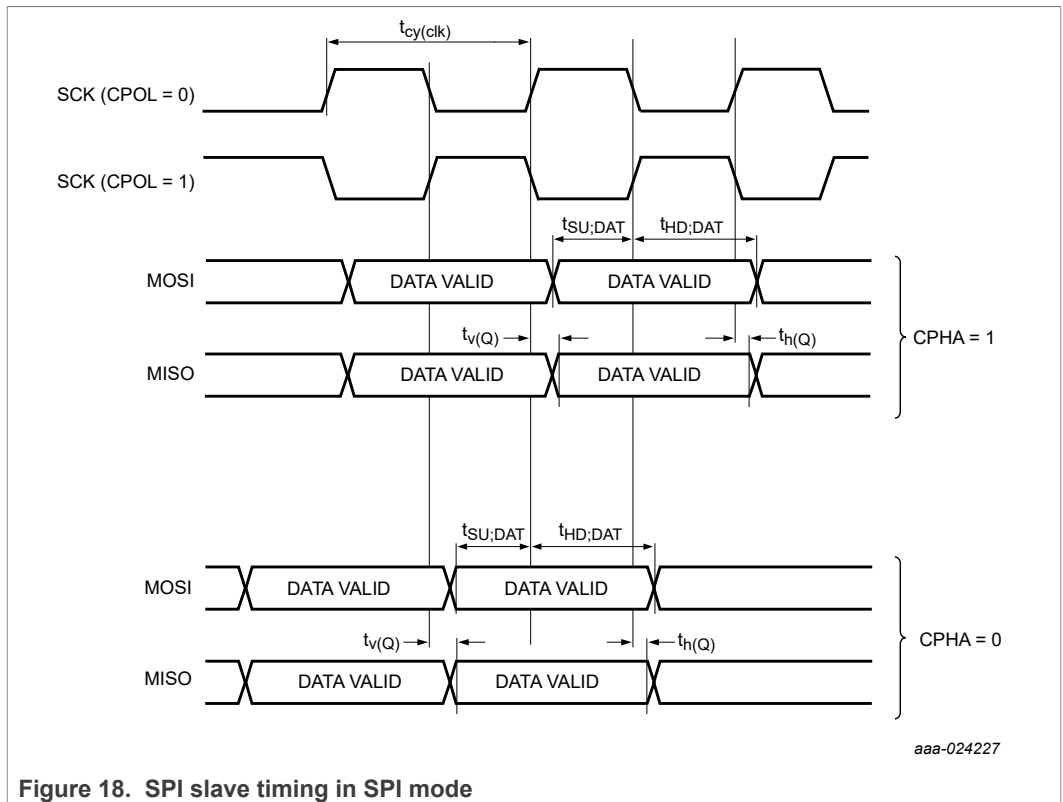

Figure 18. SPI slave timing in SPI mode

12 Package outline

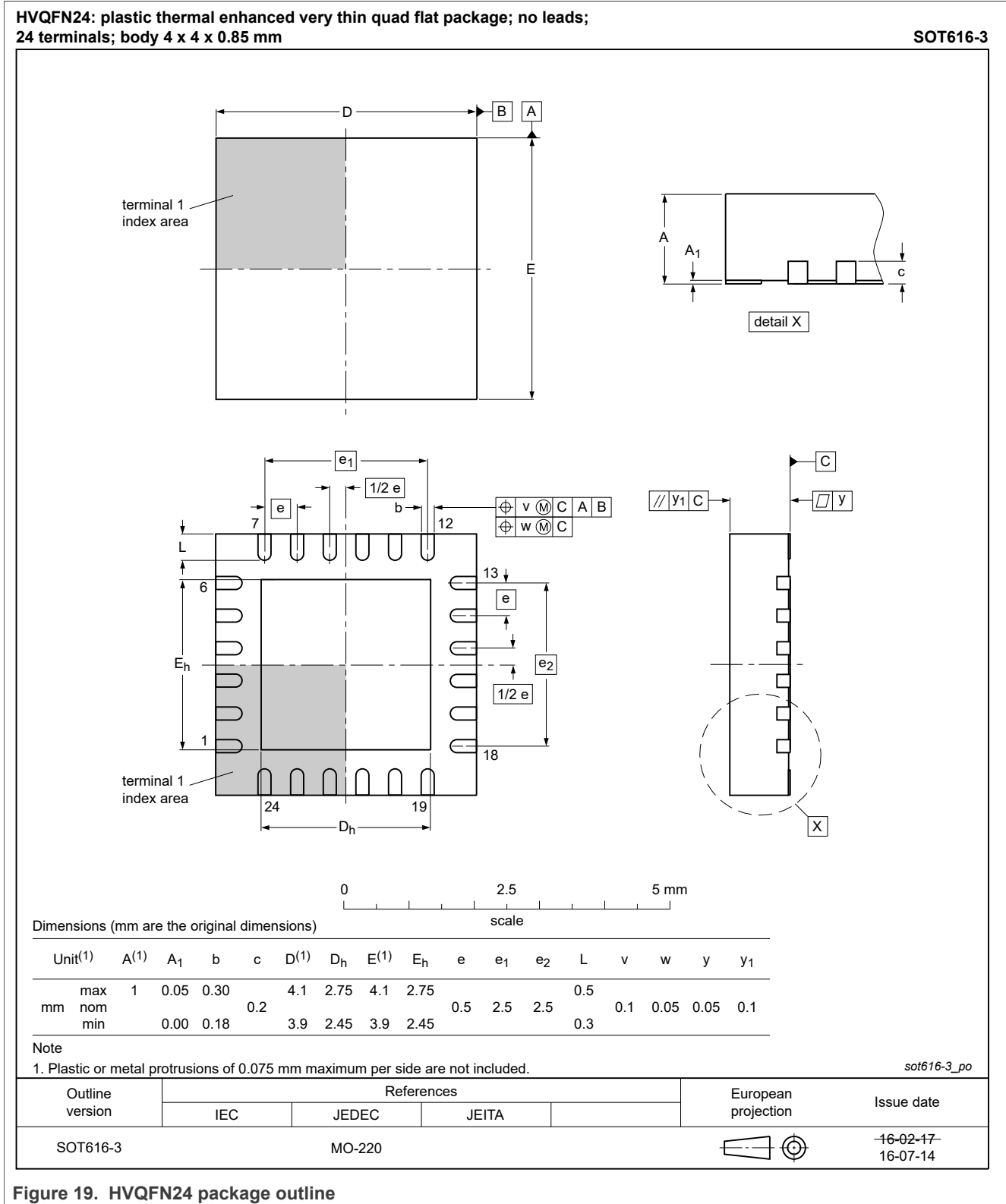

Figure 19. HVQFN24 package outline

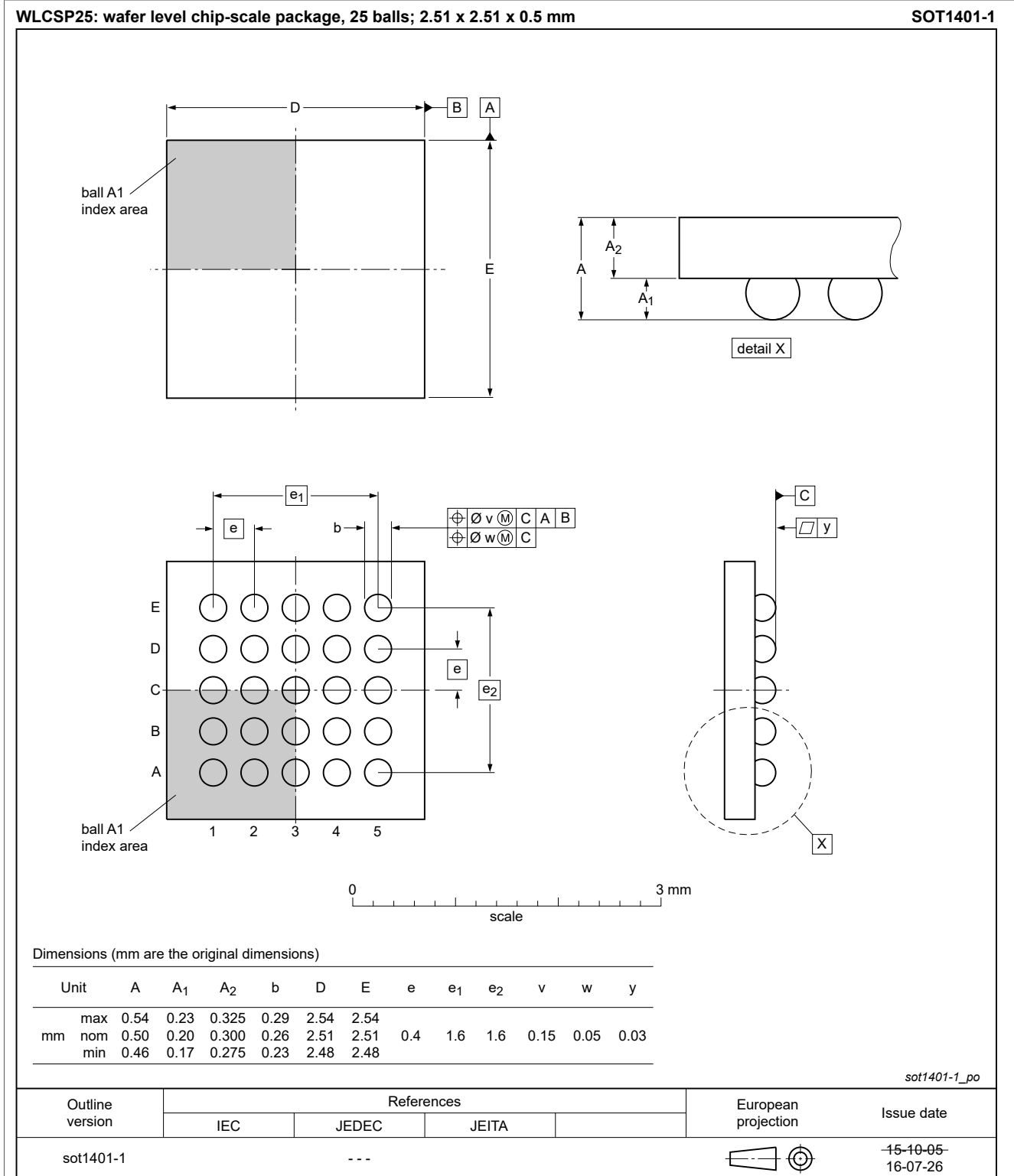

Figure 20. WLCSP25 package outline

13 Abbreviations

Table 31. Abbreviations

Acronym	Description
ADC	analog-to-digital converter
AHB	advanced high-performance bus
AMBA	advanced microcontroller bus architecture
APB	advanced peripheral bus
API	application programming interface
ARM	advanced RISC machine
BOD	brownout detection
CGU	clock generator unit
EEPROM	electrically erasable programmable read-only memory
GPIO	general-purpose input output
I ² C	inter-integrated circuit
LDO	low dropout
MISO	master input slave output
MOSI	master output slave input
NDEF	NFC data exchange format
NFC	near field communication
NVIC	nested vectored interrupt controller
PMU	power management unit
POR	power-on reset
PWM	pulse width modulation
RFID	radio frequency identification
RISC	reduced instruction set computer
RTC	real-time clock
SFRO	system free-running oscillator
SI	slave input
SO	slave output
SPI	serial peripheral interface
SR	status register
SSI	synchronous serial interface
SSP	synchronous serial port
SWD	serial wire debug
TFRO	timer free-running oscillator
WDT	watchdog timer

14 References

1	DDI0484C_cortex_m0p_r0p1_trm	Cortex-M0+ Devices - Technical Reference Manual
2	DUI0662B_cortex_m0p_r0p1_dgug	Cortex-M0+ Devices - Generic User Guide
3	UM10204 user manual	I ² C-bus specification and user manual; 2014, NXP Semiconductors

15 Revision history

Table 32. Revision history

Document ID	Release date	Data sheet status	Change notice	Supersedes
NHS3152 v.5	20210526	Product data sheet	-	NHS3152 v.4
Modifications:	<ul style="list-style-type: none"> • Table 22 in Section 10 "Static characteristics" updated. • Text has been updated throughout the document. 			
NHS3152 v.4	20190411	Product data sheet	-	NHS3152 v.3
Modifications:	<ul style="list-style-type: none"> • Section 7 "Pinning" updated. 			
NHS3152 v.3	20180615	Product data sheet	-	NHS3152 v.2
Modifications:	<ul style="list-style-type: none"> • NFC certification and logo have been added. • Text has been updated throughout the document. 			
NHS3152 v.2	20161031	Objective data sheet	-	NHS3152 v.1
Modifications	<ul style="list-style-type: none"> • Title changed from 'Therapy adherence monitor' to 'Therapy adherence resistive monitor' • Section 7 "Pinning" updated • Section 8.4 "Power management": major revision • Section 11.2 "I²C-bus" updated • Section 11.3 "SPI interfaces" added • Section 12 "Package outline": WLCSP25 package outline added • Table 23 in Section 10 "Static characteristics" updated • Section 8.8 "Fast general-purpose parallel I/O" added 			
NHS3152 v.1	20150811	Objective data sheet	-	-

16 Legal information

16.1 Data sheet status

Document status ^{[1][2]}	Product status ^[3]	Definition
Objective [short] data sheet	Development	This document contains data from the objective specification for product development.
Preliminary [short] data sheet	Qualification	This document contains data from the preliminary specification.
Product [short] data sheet	Production	This document contains the product specification.

[1] Please consult the most recently issued document before initiating or completing a design.

[2] The term 'short data sheet' is explained in section "Definitions".

[3] The product status of device(s) described in this document may have changed since this document was published and may differ in case of multiple devices. The latest product status information is available on the Internet at URL <http://www.nxp.com>.

16.2 Definitions

Draft — A draft status on a document indicates that the content is still under internal review and subject to formal approval, which may result in modifications or additions. NXP Semiconductors does not give any representations or warranties as to the accuracy or completeness of information included in a draft version of a document and shall have no liability for the consequences of use of such information.

Short data sheet — A short data sheet is an extract from a full data sheet with the same product type number(s) and title. A short data sheet is intended for quick reference only and should not be relied upon to contain detailed and full information. For detailed and full information see the relevant full data sheet, which is available on request via the local NXP Semiconductors sales office. In case of any inconsistency or conflict with the short data sheet, the full data sheet shall prevail.

Product specification — The information and data provided in a Product data sheet shall define the specification of the product as agreed between NXP Semiconductors and its customer, unless NXP Semiconductors and customer have explicitly agreed otherwise in writing. In no event however, shall an agreement be valid in which the NXP Semiconductors product is deemed to offer functions and qualities beyond those described in the Product data sheet.

16.3 Disclaimers

Limited warranty and liability — Information in this document is believed to be accurate and reliable. However, NXP Semiconductors does not give any representations or warranties, expressed or implied, as to the accuracy or completeness of such information and shall have no liability for the consequences of use of such information. NXP Semiconductors takes no responsibility for the content in this document if provided by an information source outside of NXP Semiconductors. In no event shall NXP Semiconductors be liable for any indirect, incidental, punitive, special or consequential damages (including - without limitation - lost profits, lost savings, business interruption, costs related to the removal or replacement of any products or rework charges) whether or not such damages are based on tort (including negligence), warranty, breach of contract or any other legal theory. Notwithstanding any damages that customer might incur for any reason whatsoever, NXP Semiconductors' aggregate and cumulative liability towards customer for the products described herein shall be limited in accordance with the Terms and conditions of commercial sale of NXP Semiconductors.

Right to make changes — NXP Semiconductors reserves the right to make changes to information published in this document, including without limitation specifications and product descriptions, at any time and without

notice. This document supersedes and replaces all information supplied prior to the publication hereof.

Suitability for use — NXP Semiconductors products are not designed, authorized or warranted to be suitable for use in life support, life-critical or safety-critical systems or equipment, nor in applications where failure or malfunction of an NXP Semiconductors product can reasonably be expected to result in personal injury, death or severe property or environmental damage. NXP Semiconductors and its suppliers accept no liability for inclusion and/or use of NXP Semiconductors products in such equipment or applications and therefore such inclusion and/or use is at the customer's own risk.

Applications — Applications that are described herein for any of these products are for illustrative purposes only. NXP Semiconductors makes no representation or warranty that such applications will be suitable for the specified use without further testing or modification. Customers are responsible for the design and operation of their applications and products using NXP Semiconductors products, and NXP Semiconductors accepts no liability for any assistance with applications or customer product design. It is customer's sole responsibility to determine whether the NXP Semiconductors product is suitable and fit for the customer's applications and products planned, as well as for the planned application and use of customer's third party customer(s). Customers should provide appropriate design and operating safeguards to minimize the risks associated with their applications and products. NXP Semiconductors does not accept any liability related to any default, damage, costs or problem which is based on any weakness or default in the customer's applications or products, or the application or use by customer's third party customer(s). Customer is responsible for doing all necessary testing for the customer's applications and products using NXP Semiconductors products in order to avoid a default of the applications and the products or of the application or use by customer's third party customer(s). NXP does not accept any liability in this respect.

Limiting values — Stress above one or more limiting values (as defined in the Absolute Maximum Ratings System of IEC 60134) will cause permanent damage to the device. Limiting values are stress ratings only and (proper) operation of the device at these or any other conditions above those given in the Recommended operating conditions section (if present) or the Characteristics sections of this document is not warranted. Constant or repeated exposure to limiting values will permanently and irreversibly affect the quality and reliability of the device.

Terms and conditions of commercial sale — NXP Semiconductors products are sold subject to the general terms and conditions of commercial sale, as published at <http://www.nxp.com/profile/terms>, unless otherwise agreed in a valid written individual agreement. In case an individual agreement is concluded only the terms and conditions of the respective agreement shall apply. NXP Semiconductors hereby expressly objects to applying the customer's general terms and conditions with regard to the purchase of NXP Semiconductors products by customer.

No offer to sell or license — Nothing in this document may be interpreted or construed as an offer to sell products that is open for acceptance or the grant, conveyance or implication of any license under any copyrights, patents or other industrial or intellectual property rights.

Export control — This document as well as the item(s) described herein may be subject to export control regulations. Export might require a prior authorization from competent authorities.

Non-automotive qualified products — Unless this data sheet expressly states that this specific NXP Semiconductors product is automotive qualified, the product is not suitable for automotive use. It is neither qualified nor tested in accordance with automotive testing or application requirements. NXP Semiconductors accepts no liability for inclusion and/or use of non-automotive qualified products in automotive equipment or applications. In the event that customer uses the product for design-in and use in automotive applications to automotive specifications and standards, customer (a) shall use the product without NXP Semiconductors' warranty of the product for such automotive applications, use and specifications, and (b) whenever customer uses the product for automotive applications beyond NXP Semiconductors' specifications such use shall be solely at customer's own risk, and (c) customer fully indemnifies NXP Semiconductors for any liability, damages or failed product claims resulting from customer design and use of the product for automotive applications beyond NXP Semiconductors' standard warranty and NXP Semiconductors' product specifications.

Translations — A non-English (translated) version of a document is for reference only. The English version shall prevail in case of any discrepancy between the translated and English versions.

16.4 Licenses

Purchase of NXP ICs with NFC technology

Purchase of an NXP Semiconductors IC that complies with one of the Near Field Communication (NFC) standards ISO/IEC 18092 and ISO/IEC 21481 does not convey an implied license under any patent right infringed by implementation of any of those standards. Purchase of NXP Semiconductors IC does not include a license to any NXP patent (or other IP right) covering combinations of those products with other products, whether hardware or software.

16.5 Trademarks

Notice: All referenced brands, product names, service names and trademarks are the property of their respective owners.

MIFARE — is a trademark of NXP B.V.

Contents

1	General description	1	8.13	32-bit timer	25
2	Features and benefits	2	8.13.1	Features	25
2.1	System	2	8.13.2	General description	25
2.2	Memory	2	8.14	Watchdog Timer (WDT)	26
2.3	Digital peripherals	2	8.14.1	Features	26
2.4	Analog peripherals	2	8.14.2	General description	26
2.5	Flexible analog on-chip switch	2	8.15	System tick timer	26
2.6	Communication interfaces	2	8.15.1	Features	26
2.7	Clock generation	3	8.15.2	General description	26
2.8	Power control	3	8.16	Real-Time Clock (RTC) timer	27
2.9	General	3	8.16.1	Features	27
3	Applications	3	8.16.2	General description	27
4	Ordering information	3	8.17	Temperature sensor	27
5	Marking	3	8.17.1	Features	27
6	Block diagram	4	8.17.2	General description	27
7	Pinning	5	8.18	Current-to-Digital converter (I2D)	28
7.1	HVQFN24	5	8.18.1	General description	28
7.2	WLCSP25	7	8.18.2	Specifications	28
8	Functional description	10	8.18.3	Input multiplexer	29
8.1	Arm Cortex-M0+ core	10	8.19	Analog-to-Digital Converter/Digital-to- Analog Converter 0 (ADC/DAC0)	30
8.2	Memory map	10	8.19.1	Features	30
8.3	System configuration	11	8.19.2	General description	30
8.3.1	Clock generation	11	8.19.3	Input multiplexer and output switch matrix	30
8.3.2	Reset	12	8.20	Using NHS3152 to measure resistance	31
8.4	Power management	13	8.20.1	Measurement principle	31
8.4.1	System power architecture	13	8.21	Serial Wire Debug (SWD)	31
8.4.2	Power management unit (PMU)	16	8.22	On-chip flash memory	32
8.5	Nested Vectored Interrupt Controller (NVIC)	16	8.22.1	Reading from flash	32
8.5.1	Features	16	8.22.2	Writing to flash	32
8.5.2	Interrupt sources	17	8.22.3	Erasing/programming flash	32
8.6	Analog signal buses	18	8.23	On-chip SRAM	32
8.7	I/O configuration	18	8.24	On-chip EEPROM	32
8.7.1	PIO0 pin mode	19	8.24.1	Reading from EEPROM	32
8.7.2	PIO0 I2C-bus mode	19	8.24.2	Writing to EEPROM	33
8.7.3	PIO0 current source mode	19	9	Limiting values	34
8.7.4	ANA0 input selection	19	10	Static characteristics	35
8.8	Fast general-purpose parallel I/O	20	11	Dynamic characteristics	39
8.8.1	Features	20	11.1	I/O pins	39
8.9	I2C-bus controller	20	11.2	I2C-bus	39
8.9.1	Features	20	11.3	SPI interfaces	40
8.9.2	General description	21	12	Package outline	42
8.9.3	I2C-bus pin description	21	13	Abbreviations	44
8.10	SPI controller	22	14	References	45
8.10.1	Features	22	15	Revision history	45
8.10.2	General description	22	16	Legal information	46
8.10.3	Pin description	22			
8.10.3.1	Pin detailed description	22			
8.11	RFID/NFC communication unit	23			
8.11.1	Features	23			
8.11.2	General description	23			
8.12	16-bit timer	24			
8.12.1	Features	24			
8.12.2	General description	24			

Please be aware that important notices concerning this document and the product(s) described herein, have been included in section 'Legal information'.

Mouser Electronics

Authorized Distributor

Click to View Pricing, Inventory, Delivery & Lifecycle Information:

[NXP:](#)

[NHS3152/A1](#) [NHS3152/A1Z](#) [NHS3152UK/A1Z](#) [NHS3152DBUL](#) [NHS3152TEMOADKUL](#)