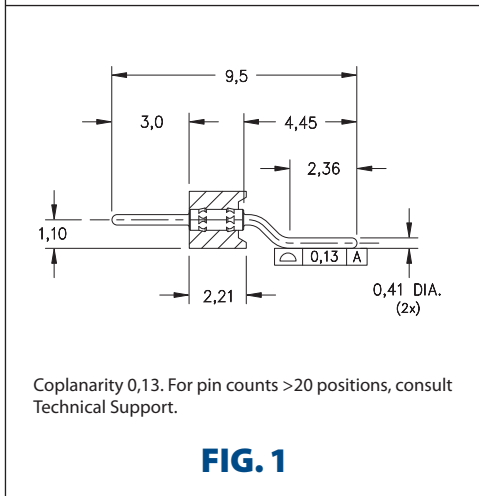
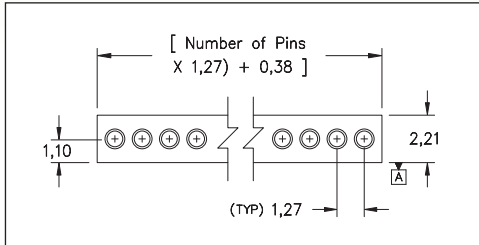
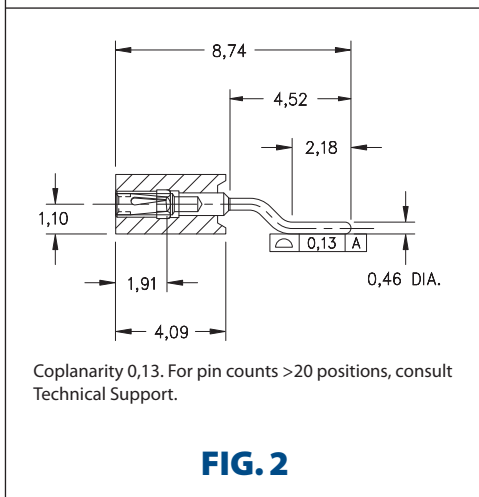
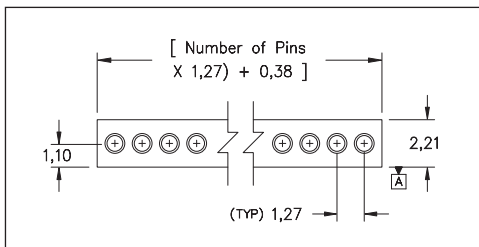


# INTERCONNECTS

## SERIES 850 & 851 • 1,27 GRID HORIZONTAL SURFACE MOUNT Z-BEND HEADERS & SOCKETS • SINGLE ROW STRIPS

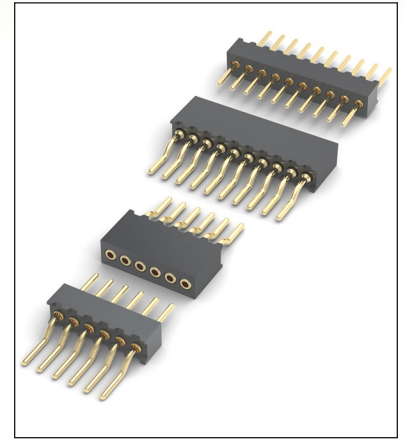


**FIG. 1**












**FIG. 2**

- Series 850 horizontal surface mount headers have 0,41 dia. pluggable pins and Z-bend tails for SMT soldering to the P.C.B. (MM #4006-1). See page 208 for details
- Series 851 horizontal Surface Mount Z-Bend sockets uses MM #4890-1 receptacles that accept pin diameters from 0,38 - 0,51. See page 160 for details
- Receptacles use Hi-Rel, 3-finger BeCu #11 contact rated at 3 amps. See page 251 for details
- Insulators are high temperature thermoplastic, suitable for all soldering operations



### ORDERING INFORMATION

<b>FIG. 1</b>	<b>Series 850...001 Single Row Surface Mount Z-Bend Header</b>					
	850-10-0-40-001000					
	Specify number of pins		02-20			
  						
<b>SPECIFY PLATING CODE XX=</b>		10				
Pin Plating			0,25µm Au			

<b>FIG. 2</b>	<b>Series 851...001 Single Row Surface Mount Z-Bend Socket</b>					
	851-XX-0-40-001000					
	Specify number of pins		02-20			
  						
<b>SPECIFY PLATING CODE XX=</b>		11	13			
Sleeve (Pin)			0,25µm Au	0,25µm Au		
Contact (Clip)			0,25µm Au	0,76µm Au		



# Mouser Electronics

Authorized Distributor

Click to View Pricing, Inventory, Delivery & Lifecycle Information:

## Mill-Max:

[851-13-010-40-001000](#) [851-13-003-40-001000](#) [851-13-009-40-001000](#) [850-10-009-40-001000](#) [851-13-002-40-001000](#) [851-11-008-40-001000](#) [851-11-012-40-001000](#) [851-11-014-40-001000](#) [851-11-009-40-001000](#) [851-11-018-40-001000](#) [851-13-012-40-001000](#) [851-11-010-40-001000](#) [851-11-016-40-001000](#) [851-11-005-40-001000](#) [851-11-017-40-001000](#) [851-11-015-40-001000](#) [851-11-020-40-001000](#) [851-11-013-40-001000](#) [851-11-007-40-001000](#) [851-11-019-40-001000](#) [851-11-011-40-001000](#) [851-11-002-40-001000](#)