

EM-T-7A Safety Extension Module

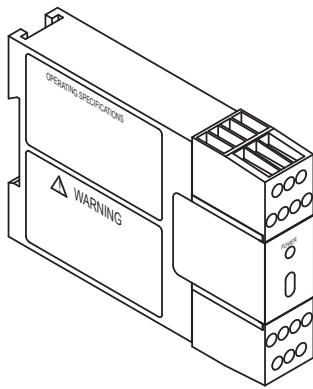

Datasheet



- Extension Module provides additional safety outputs for a Primary Safety Device (for example, an E-stop Safety Module or a 2-hand control module), if controlled and monitored by this device
- Features four 6-amp switching channels for connection to control-reliable machine power interrupt circuits
- Four redundant output channels
- Contact status outputs are provided for connection to the Primary Safety Device's monitoring input
- 24 V dc operation
- Housed in a narrow, 22.5 mm (0.9 in) DIN-rail-mountable module
- Convenient plug-in terminal blocks
- Design complies with standards UL 991 and EN 60204

Overview

The EM-T-7A Safety Extension Module provides additional forced-guided (positive-guided) relay contacts for a Primary Safety Device, such as an E-stop Safety Module or a two-hand-control module. Controlled by the safety outputs of the Primary Safety Device, the EM-T-7A Module provides four redundant outputs. These outputs may be connected to control-reliable machine power interrupt circuits. Each of the four Extension Module outputs is a series connection of two forced-guided relay contacts (K1 and K2).

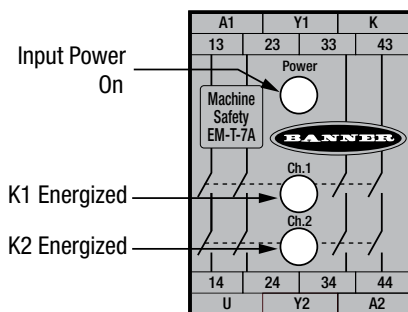

The outputs of the Extension Module follow the action of the safety outputs from the Primary Safety Device which control it, within a maximum switching delay time of 20 ms. The Extension Module's four outputs are each rated for up to 250 V ac/dc at up to 6 A.

The Extension Module offers an output circuit at terminals Y1 and Y2 which provides K1 and K2 contact status information for connection to the monitoring input of the Primary Safety Device. This monitoring circuit prevents the Primary Safety Device from being reset if contacts of either K1 or K2 of the Extension Module fail in a shorted condition.

The Extension Module has indicators for input power (green), and status of internal relays (K1 and K2, both green). There are no adjustments and no user-serviceable parts.



WARNING:

- This Safety Extension Module is not a point-of-operation guarding device, as defined by OSHA regulations.
- Failure to install point-of-operation guards on hazardous machinery could lead to serious injury or death.
- Install point-of-operation guarding devices, such as safety light screens and/or hard guards, to protect personnel from hazardous machinery.

Important... Read this before proceeding!

The user is responsible for satisfying all local, state, and national laws, rules, codes, and regulations relating to the use of this product and its application. Banner Engineering Corp. has made every effort to provide complete application, installation, operation, and maintenance instructions. Please contact a Banner Applications Engineer with any questions regarding this product.

The user is responsible for making sure that all machine operators, maintenance personnel, electricians, and supervisors are thoroughly familiar with and understand all instructions regarding the installation, maintenance, and use of this product, and with the machinery it controls. The user and any personnel involved with the installation and use of this product must be thoroughly familiar with all applicable standards, some of which are listed within the specifications. Banner Engineering Corp. makes no claim regarding a specific recommendation of any organization, the accuracy or effectiveness of any information provided, or the appropriateness of the provided information for a specific application.



Standards Applicable to the Use of Primary Safety Devices

U.S. Standards

ANSI B11 Standards for Machine Tools Safety

Contact: Safety Director, AMT – The Association for Manufacturing Technology, 7901 Jones Branch Drive, Suite 900, McLean, VA 22102-4206 USA, www.amtonline.org

NFPA 79 Electrical Standard for Industrial Machinery

Contact: National Fire Protection Association, 1 Batterymarch Park, Quincy, MA 02169-7471 USA, www.nfpa.org/

ANSI/RIA R15.06 Safety Requirements for Industrial Robots and Robot Systems

Contact: Robotic Industries Association, 900 Victors Way, Suite 140, Ann Arbor, MI 48108 USA, www.robotics.org

European Standards

EN ISO 12100 Safety of Machinery – Basic Concepts, General Principles for Design

EN 60204-1 Electrical Equipment of Machines Part 1: General Requirements - Also, request a type "C" standard for your specific machinery

ISO 13850 (EN 418) Emergency Stop Devices, Functional Aspects – Principles for Design

Contact: IHS Markit (Global Engineering Documents), 15 Inverness Way East, Englewood, CO 80112 USA, <https://global.ih.com/>

Specifications

Supply Voltage and Current

A1-A2: 24 V dc, ±15%, 10% maximum ripple

Current:

65 mA typical at 24 V dc

100 mA maximum at 20.4 V dc

Supply Protection Voltage

Protected against reverse polarity and transient voltages

Output Response Time

20 milliseconds maximum (if channel u-k fails, maximum response time is 200 milliseconds)

Input Requirements

Inputs from Primary Safety Device must each be capable of switching 30 to 250 mA at 13 to 28 V dc

Status Indicators

3 green LED indicators: Power ON, K1 energized, and K2 energized

Construction

Polycarbonate housing

Environmental Rating

NEMA 1, IEC IP20

Extension Module must be installed inside an enclosure rated NEMA 3 (IEC IP54), or better

Vibration Resistance

10 to 55 Hz at 0.35 mm displacement per IEC 68-2-6

Operating Temperature

0 °C to +50 °C (+32 °F to +122 °F)

Application Notes

There are no adjustments and no user-serviceable parts. See page 6 for information regarding repair service.

Certifications



Output Configuration

Four output channels: Each channel is a series connection of two forced-guided (positive-guided) relay contacts – AgNi, gold-flashed

Contact ratings:

Maximum voltage: 250 V ac/dc

Maximum current: 6 A ac/dc

Minimum current: 30 mA at 24 V dc

Maximum power: 1500 VA, 200 W

Mechanical life: 50,000,000 operations

Electrical life: 100,000 at full resistive load

Feedback contact rating (Y1-Y2): 24 V dc at 0.5 A

Transient suppression is recommended when switching inductive loads. Install suppressors across load. Never install suppressors across output contacts.

Mounting

Mounts to standard 35 mm DIN-rail track

Required Overcurrent Protection



WARNING: Electrical connections must be made by qualified personnel in accordance with local and national electrical codes and regulations.

Overcurrent protection is required to be provided by end product application per the supplied table. Overcurrent protection may be provided with external fusing or via Current Limiting, Class 2 Power Supply.

Supply wiring leads < 24 AWG shall not be spliced.

For additional product support, go to www.bannerengineering.com.

Supply Wiring (AWG)	Required Overcurrent Protection (Amps)
20	5.0
22	3.0
24	2.0
26	1.0
28	0.8
30	0.5

Dimensions

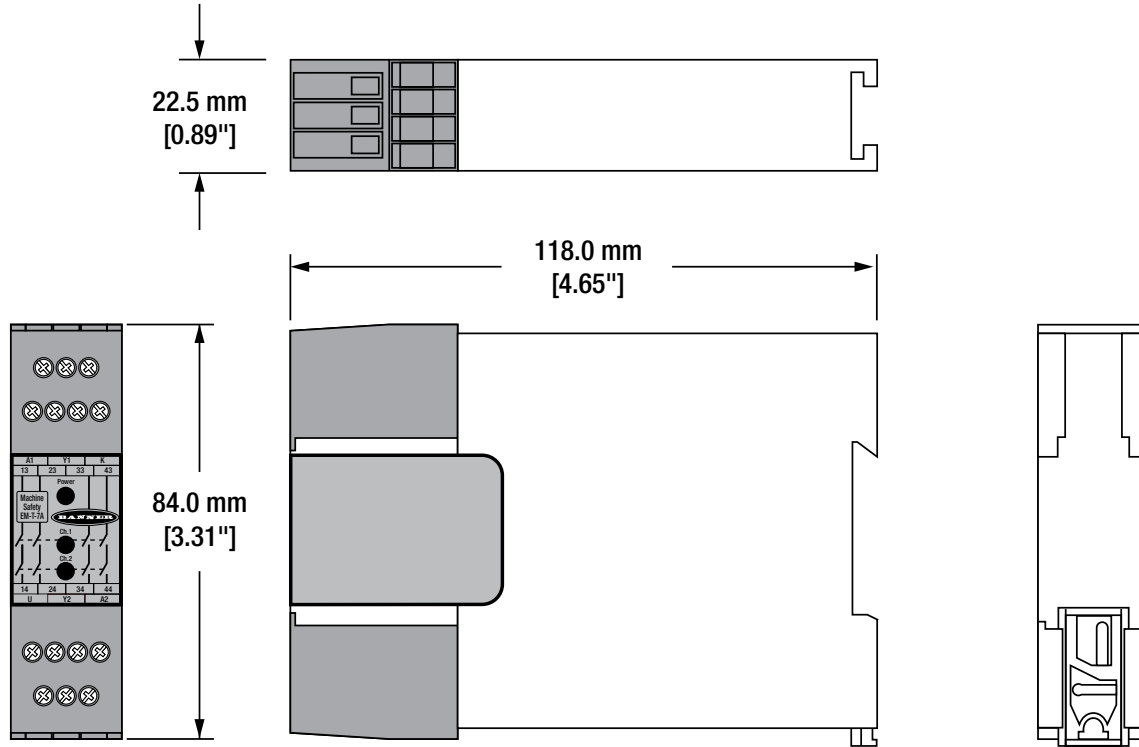

Installation Instructions

Primary Safety Device Requirements

The EM-T-7A Safety Extension Module is driven by one or two safety output channels of a Primary Safety Device. The design of the Primary Safety Device must meet OSHA and ANSI control reliability requirements. The EM-T-7A Module must be used ONLY with Primary Safety Devices which have a dedicated input for feedback monitor contacts (see wiring diagrams).

Each output channel of the Primary Safety Device must meet the following requirements:

- Include two (or more) redundant, normally open forced-guided (positive-guided) contacts,
- Be self-monitored to result in a safe (open) condition in the event of a contact failure, and
- Be capable of switching 30 to 250 mA at 13 to 28 V dc.



WARNING:

Not for Use As a Stand-Alone Safety Relay

1. DO NOT connect E-stop switches, 2-hand control switches, safety interlock switches, or similar devices directly to this Extension Module.
2. ALWAYS connect terminals Y1 and Y2 of this Extension Module to the monitoring input of the Primary Safety Device that controls it (see wiring diagram).

This Safety Extension Module does not have the circuitry required to perform a self-check. A single fault inside the unit or in external devices like switches or E-stop buttons connected to the unit can go undetected and create an unsafe condition. **Failure to properly connect this Safety Extension Module to a control-reliable Primary Safety Device could result in serious injury or death.**



WARNING: Dangerous Voltages. Always disconnect all power from the Safety Extension Module, the Primary Safety Device, and from the machine being controlled before making any wire connections. Electrical installation and wiring must be made by qualified personnel and must comply with the NEC (National Electrical Code), EN 60204-1 and -2, and all applicable local standards and codes.

Mechanical Installation

The Safety Module must be installed inside an enclosure.

It is not designed for exposed wiring. It is the user's responsibility to house the Safety Module in an enclosure with NEMA 3 (IEC IP54) rating, or better. The Safety Module mounts directly to standard 35 mm DIN rail.

Heat Dissipation Considerations: For reliable operation, ensure that the operating specifications are not exceeded. The enclosure must provide adequate heat dissipation, so that the air closely surrounding the Module does not exceed the maximum operating temperature stated in the Specifications. Methods to reduce heat build-up include venting, forced airflow (for example, exhaust fans), adequate enclosure exterior surface area, and spacing between modules and other sources of heat.

Electrical Installation

Because the Extension Module can be used with many different Primary Safety Devices and can interface to a multitude of machine control configurations, it is not possible to give exact wiring instructions for the output contacts. The following guidelines are general in nature.

The output contacts of the Extension Module have no delay function. They will open within 20 milliseconds from the time that the controlling contacts coming from the Primary Safety Device open.



Important: Review the following discussion of one-channel and two-channel control before connecting the Extension Module to its Primary Safety Device.



WARNING: Use of Arc Suppressors

If arc suppressors are used, they **MUST** be installed as shown across the coils of the Machine Primary Control Elements (MPCs). **NEVER install suppressors directly across the output contacts of the Safety Module.** It is possible for suppressors to fail as a short circuit. **If installed directly across the output contacts of the Safety Module, a short-circuited suppressor creates an unsafe condition which could result in serious injury or death.**



WARNING: Maintain Control Reliability. NEVER wire an intermediate device (e.g., a programmable logic controller/ PLC), other than a safety relay, between any safety output of the Extension Module and the master stop control element it switches. To do so sacrifices the control reliability of the control-to-machine interface, and creates an unsafe condition which could result in serious injury or death. Whenever a safety relay is added as an intermediate switching device, a normally-closed forced-guided monitor contact of that relay must be added to the series feedback loop. (Reference ANSI B11.1 – 1988, Appendix B4)

One-Channel Control

Figure 1. Generalized EM-T-7A Wiring for One-Channel Control

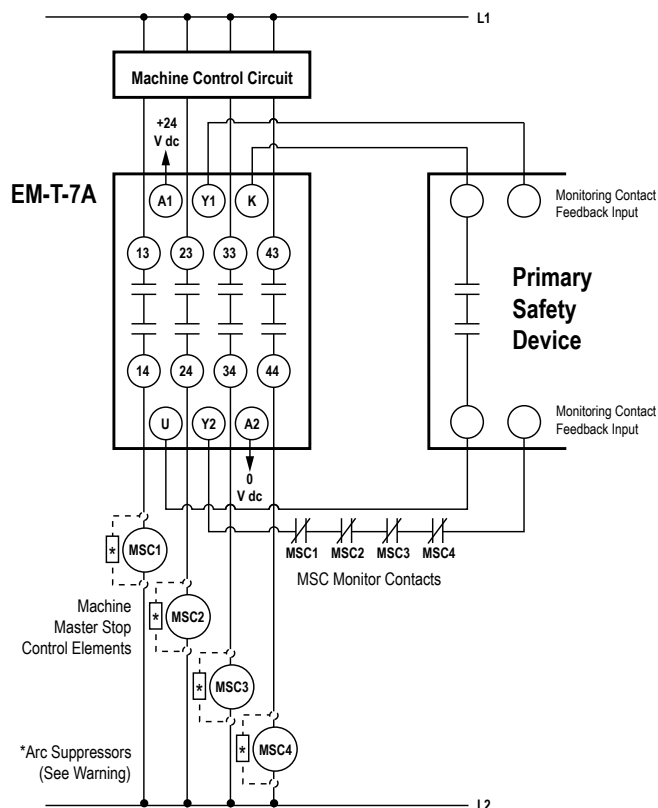

One-channel control affords simplicity of wiring. However, one-channel wiring requires eliminating the possibility of an unsafe failure of the control wires (which connect the output of the Primary Safety Device to the input of the Extension Module). One of the ways to reduce the probability of such failure is to locate the Primary Safety Device adjacent to the Extension Module in the same enclosure.

The output of the Primary Safety Device must consist of two or more series-connected, normally open contacts, coming from forced-guided safety relays. These contacts must be monitored for failure by the Primary Safety Device. In addition, a single contact failure cannot prevent normal stopping action, and a successive cycle cannot be initiated until the failure has been corrected. An example of this type of output is any single output channel of a Banner E-stop safety module.

Two-Channel Control

Figure 2. Generalized EM-T-7A Wiring for Two-Channel Control

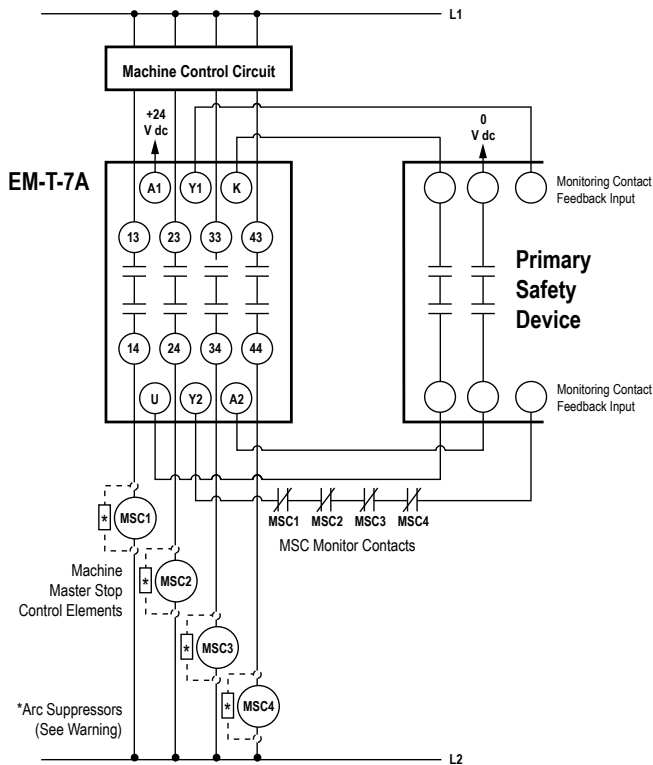

Two-channel control allows the Primary Safety Device to detect an unsafe failure of the control wires. Two-channel control should be used whenever unsafe failure of the control wires cannot be eliminated.

The outputs of the Primary Safety Device must each be normally open, forced-guided contacts from redundant safety relays. These contacts must be monitored for failure by the Primary Safety Device. In addition, a single contact failure cannot prevent normal stopping action, and a successive cycle cannot be initiated until the failure has been corrected.

Connection to the Machine to be Controlled

The wiring diagrams show a generic connection of the four safety output channels of the Extension Module to Master Stop Control Elements MSC1 through MSC4. A Master Stop Control Element is defined as an electrically powered device, external to the Extension Module, which stops the machinery being controlled by immediate removal of electrical power to the machine and (when necessary) by applying braking to dangerous motion (reference ANSI B11.19, section 5.2: "Stop Control"). To achieve control reliability, two redundant MSCs are required to control each machine hazard.

To satisfy the requirements of control reliability, all MSCs must offer at least one normally closed forced-guided monitor contact. One normally closed monitor contact from each MSC is wired in series to the monitoring contact feedback input of the Primary Safety Device, as shown in the wiring diagrams. In operation, if one of the switching contacts of any MSC fails in the shorted condition, the associated monitor contact will remain open. As a result, it will not be possible to reset the Primary Safety Device.

Many types of mechanisms are used to arrest dangerous machine motion. Examples include mechanical braking systems, clutch mechanisms, and combinations of brakes and clutches. Additionally, control of the arresting scheme may be hydraulic or pneumatic. As a result, an MSC may be one of several control types, including a wide variety of contactors and electromechanical valves. If your machine documentation leaves any doubt about the proper connection points for the Extension Module output contacts, do not make any connections. Contact the machine builder for clarification regarding connection to the MSCs.



Note: NOTICE regarding MSCs. To achieve control reliability, two redundant Master Stop Control Elements (MSCs) are required to control each machine hazard. Each MSC must be capable of immediately stopping the dangerous machine motion, irrespective of the state of the other. Some machines offer only one primary control element. For such machines, it is necessary to duplicate the circuit of the single MSC to add a second MSC.

MSCs must offer at least one forced-guided auxiliary contact which is wired to the monitoring contact feedback input of the Primary Safety Device (see wiring diagrams).



WARNING: MSC Monitoring. All Master Stop Control elements (MSCs), such as control relays, must be of forced-guided, captive contact design to allow the MSC Monitoring circuit to detect unsafe failures within the master stop control elements. This monitoring extends the safe switching point of the Primary Safety Device and the EM-T-7A Extension Module to the MSC elements. For this monitoring to be effective, it is required that a minimum of two redundant MSCs control each hazard. This is to detect the unsafe failure of one MSC (e.g. a welded contact), while stopping the hazard and preventing a successive machine cycle with the second MSC.

If the MSCs are the last electrically controlled device generating the hazard (i.e. not relays or contactors) and do not have forced-guided, captive contacts to monitor, then the customer must ensure that failure or fault of any single component of the MSCs will not result in a hazardous situation and will prevent a successive machine cycle.

MSC Monitoring is also called External Device Monitoring (EDM), MPCE Feedback, and relay backchecking.

Initial Checkout Procedure

The Safety Extension Module can be used safely only when its operation is controlled via an appropriate Primary Safety Device, connected to the Extension Module according to the wiring diagram.



CAUTION: Disconnect Power Prior to Checkout

Before performing the initial checkout procedure, make certain all power is disconnected from the machine to be controlled.

Dangerous voltages may be present along the Safety Module wiring barriers whenever power to the machine control elements is On. **Exercise extreme caution whenever machine control power is or may be present.**

Always disconnect power to the machine control elements before opening the enclosure housing of the Safety Module.

1. Remove the power controlling (and switched by) the machine control elements.
2. Verify that the Primary Safety Device which will be controlling the Safety Extension Module is operating correctly, according to its product documentation and manufacturer's recommendations.
3. Confirm proper connection of the Safety Extension Module to the controlling Primary Safety Device according to the wiring diagram.
4. Verify that all four Safety Extension Module output contacts follow exactly the operation of the safety output contacts of the controlling Primary Safety Device, within the specified delay time, when the Primary Safety Device is operated according to its product documentation and manufacturer's recommendations.

Periodic Checkout Procedure

The checkout procedures should be performed according to the intervals specified by the product documentation of the Primary Safety Device controlling this Safety Extension Module.

Repairs

Contact Banner Engineering for troubleshooting of this device. **Do not attempt any repairs to this Banner device; it contains no field-replaceable parts or components.** If the device, device part, or device component is determined to be defective by a Banner Applications Engineer, they will advise you of Banner's RMA (Return Merchandise Authorization) procedure.



Important: If instructed to return the device, pack it with care. Damage that occurs in return shipping is not covered by warranty.

Banner Engineering Corp. Limited Warranty

Banner Engineering Corp. warrants its products to be free from defects in material and workmanship for one year following the date of shipment. Banner Engineering Corp. will repair or replace, free of charge, any product of its manufacture which, at the time it is returned to the factory, is found to have been defective during the warranty period. This warranty does not cover damage or liability for misuse, abuse, or the improper application or installation of the Banner product.

THIS LIMITED WARRANTY IS EXCLUSIVE AND IN LIEU OF ALL OTHER WARRANTIES WHETHER EXPRESS OR IMPLIED (INCLUDING, WITHOUT LIMITATION, ANY WARRANTY OF MERCHANTABILITY OR FITNESS FOR A PARTICULAR PURPOSE), AND WHETHER ARISING UNDER COURSE OF PERFORMANCE, COURSE OF DEALING OR TRADE USAGE.

This Warranty is exclusive and limited to repair or, at the discretion of Banner Engineering Corp., replacement. **IN NO EVENT SHALL BANNER ENGINEERING CORP. BE LIABLE TO BUYER OR ANY OTHER PERSON OR ENTITY FOR ANY EXTRA COSTS, EXPENSES, LOSSES, LOSS OF PROFITS, OR ANY INCIDENTAL, CONSEQUENTIAL OR SPECIAL DAMAGES RESULTING FROM ANY PRODUCT DEFECT OR FROM THE USE OR INABILITY TO USE THE PRODUCT, WHETHER ARISING IN CONTRACT OR WARRANTY, STATUTE, TORT, STRICT LIABILITY, NEGLIGENCE, OR OTHERWISE.**

Banner Engineering Corp. reserves the right to change, modify or improve the design of the product without assuming any obligations or liabilities relating to any product previously manufactured by Banner Engineering Corp. Any misuse, abuse, or improper application or installation of this product or use of the product for personal protection applications when the product is identified as not intended for such purposes will void the product warranty. Any modifications to this product without prior express approval by Banner Engineering Corp will void the product warranties. All specifications published in this document are subject to change; Banner reserves the right to modify product specifications or update documentation at any time. Specifications and product information in English supersede that which is provided in any other language. For the most recent version of any documentation, refer to: www.bannerengineering.com.

For patent information, see www.bannerengineering.com/patents.



more sensors, more solutions

Mouser Electronics

Authorized Distributor

Click to View Pricing, Inventory, Delivery & Lifecycle Information:

[Banner Engineering:](#)

[EM-T-7A](#)