

PART NO.	"A" REF	"B" REF FOR PART	"C"	"D"
FCCS-1	1.06 [27.0]	.59 [15.0]	.031 [0.80]	.13 [3.4]
FCCS-2	1.65 [42.0]	1.18 [30.0]	.039 [1.0]	.15 [3.7]
FCCS-3	1.85 [47.0]	1.38 [35.0]		
FCCS-4	2.24 [57.0]	1.77 [45.0]	.047 [1.20]	
FCCS-5	2.83 [72.0]	2.36 [60.0]	.059 [1.50]	

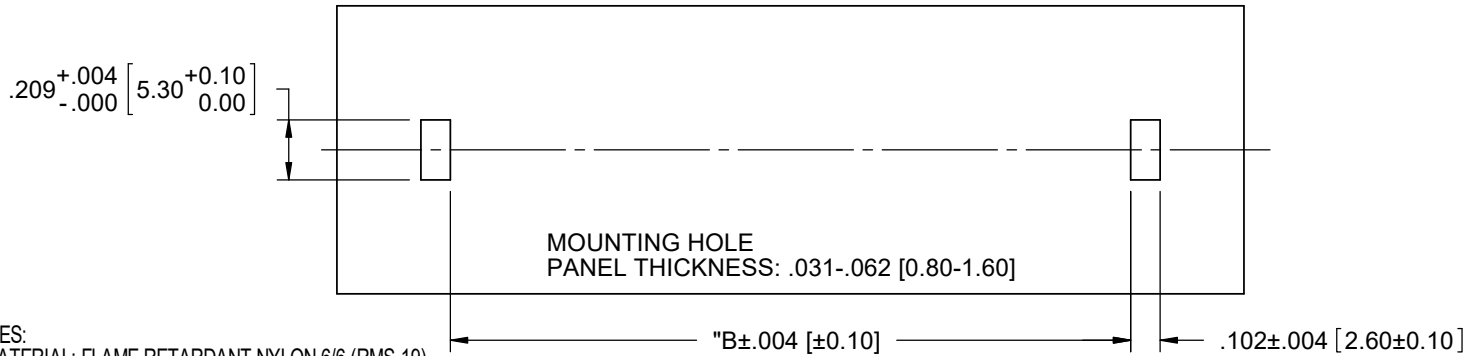
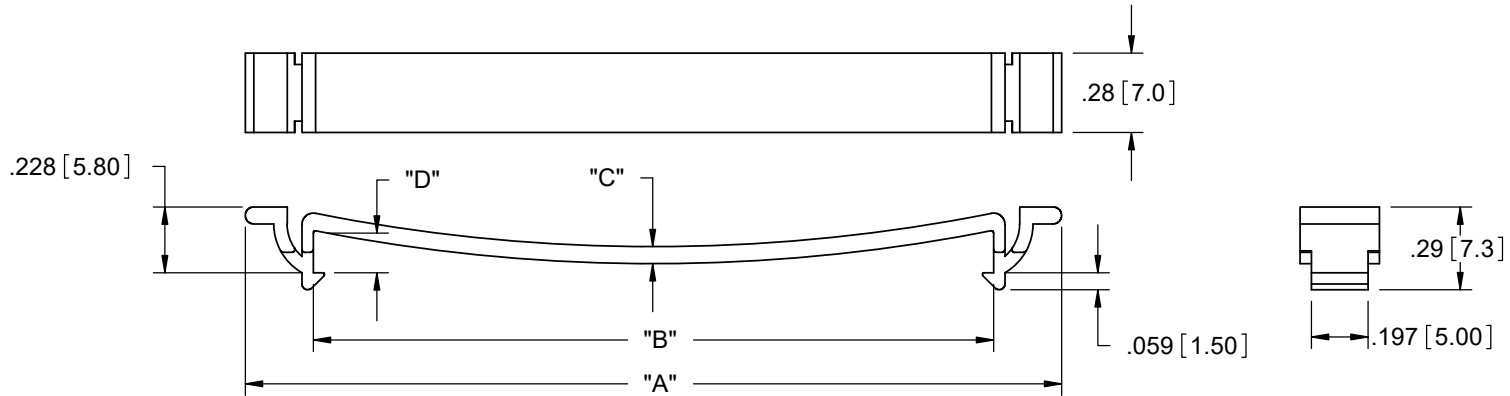

NOTES:  
 1. MATERIAL: FLAME RETARDANT NYLON 6/6 (RMS-19)  
 NYLON 6/6 (RMS-01) AVAILABLE BY SPECIAL ORDER.  
 2. COLOR: NATURAL.  
 BLACK AVAILABLE BY SPECIAL ORDER.  
 TO ORDER USE PART NO. FCCS-XBK

TITLE: <b>FLAT CABLE CLAMP, SNAP-IN</b>				UNITS: INCH [mm]	
CREATED USING SOLIDWORKS		FILE #: FCCS	DWN: SK	APP: SK	FINAL
TOLERANCES UNLESS NOTED .XX=±.010 .XXX=±.005 FRAC.=±1/64 ANG.=±1°		SHEET: 1 OF 1	SHEET SIZE: A	DT: 05/26/2005	CHKD: SJ
RE: RICHCO, INC.		RICHCO, INC. ENG@RICHCO-INC.COM (773) 539-4060		PART #	PRINT TYPE
SEE TABLE		CA			

REV.	DESCRIPTION	ENGR.	DATE
C	MADE "A" AND "B" PART DIMENSIONS REF. ECN # 1448	DZ	06/05/2019
B	ADDED COLOR BLACK. SEE CO 200697	SK	08/15/2011
A	RELEASED FOR PRODUCTION	SK	06/09/2005

# Mouser Electronics

Authorized Distributor

Click to View Pricing, Inventory, Delivery & Lifecycle Information:

[Essentra:](#)

[FCCS-1](#) [FCCS-2](#) [FCCS-3](#) [FCCS-4](#) [FCCS-5](#)