



MCDP2900

DisplayPort1.4a to HDMI2.0b Protocol Converter with HDCP2.3 Repeater

Kinetic Technologies cannot assume responsibility for use of any circuitry other than circuitry entirely embodied in a Kinetic Technologies product. No intellectual property or circuit patent licenses are implied. Kinetic Technologies reserves the right to change the circuitry and specifications without notice at any time.

Contents

| | |
|--|----|
| 1. Description | 9 |
| 2. Application overview | 10 |
| 2.1. Adaptor application | 10 |
| 2.2. Docking station application | 10 |
| 2.3. TV Application | 11 |
| 3. System block diagram | 11 |
| 4. Interface description | 12 |
| 4.1. Input interface | 12 |
| 4.1.1. Video stream regeneration | 12 |
| 4.1.2. Horizontal blanking expansion | 13 |
| 4.1.3. On-chip video pattern generation | 13 |
| 4.1.4. Audio stream regeneration | 13 |
| 4.1.5. HDCP RX | 13 |
| 4.2. Output interface | 13 |
| 4.2.1. HDMI transmitter | 13 |
| 4.2.2. HDCP TX | 14 |
| 4.2.3. DDC master | 14 |
| 4.2.4. HDMITX_HPD | 14 |
| 4.2.5. CEC | 14 |
| 4.3. Chip power-up sequence and reset | 14 |
| 4.4. Clock generation | 15 |
| 4.4.1. Internal crystal oscillator operation | 16 |
| 4.4.2. Crystal specifications | 17 |
| 5. Chip operation | 18 |
| 5.1. Initial state | 18 |

| | | |
|--------|--|----|
| 5.2. | Video pixel processing | 18 |
| 5.2.1. | Color Space Converter | 18 |
| 5.2.2. | Horizontal Chroma Down-Sampler | 19 |
| 5.2.3. | Vertical Chroma Down-Sampler | 19 |
| 5.3. | Power management..... | 19 |
| 5.4. | HDCP operation..... | 21 |
| 5.5. | CEC tunneling over AUX | 22 |
| 6. | System interface | 23 |
| 6.1. | I2C interface..... | 23 |
| 6.2. | SPI interface | 23 |
| 6.3. | UART interface | 23 |
| 6.4. | GPIO interface | 24 |
| 6.5. | Locking of system interfaces..... | 24 |
| 7. | BGA footprints and pin list..... | 25 |
| 7.1. | Signal mapping sorted by ball (pin) number | 26 |
| 8. | Connections | 29 |
| 8.1. | Pin list | 29 |
| 8.2. | Bootstrap configuration | 33 |
| 8.3. | EXT_RESETN connection | 33 |
| 9. | Package | 34 |
| 9.1. | Package drawing | 34 |
| 9.2. | LFPGA 7 x 7 dimensions | 35 |
| 9.3. | Marking field template and descriptors | 36 |
| 9.4. | Classification reflow profile | 36 |
| 10. | Electrical specifications | 37 |
| 10.1. | Absolute maximum ratings | 37 |
| 10.2. | Power connections..... | 38 |

| | |
|---|----|
| 10.3. DC characteristics | 39 |
| 10.4. AC characteristics | 40 |
| 10.4.1. DisplayPort receiver..... | 41 |
| 10.4.2. HDMI transmitter I/O specifications | 42 |
| 10.4.3. I2C interface timing..... | 43 |
| 10.4.4. SPI interface timing..... | 44 |
| 11. Ordering information | 45 |

List of tables

| | | |
|-----------|---|----|
| Table 1. | Crystal specifications..... | 17 |
| Table 2. | MCDP2900 power saving states | 20 |
| Table 3. | HDCP operations of MCDP2900..... | 22 |
| Table 4. | Pin list..... | 26 |
| Table 5. | DisplayPort receiver pins..... | 29 |
| Table 6. | HDMI output pins..... | 30 |
| Table 7. | System interface pins | 31 |
| Table 8. | Power and ground pins | 32 |
| Table 9. | Bootstrap configuration | 33 |
| Table 10. | MCDP2900 package dimensions | 35 |
| Table 11. | Field descriptors | 36 |
| Table 12. | Absolute maximum ratings | 37 |
| Table 13. | DC characteristics..... | 39 |
| Table 14. | IO DC characteristics..... | 40 |
| Table 15. | Maximum speed of operation | 40 |
| Table 15. | DisplayPort receiver characteristics..... | 41 |
| Table 16. | HDMI transmitter DC specifications..... | 42 |
| Table 17. | HDMI transmitter AC characteristics..... | 42 |
| Table 18. | I2C interface timing..... | 43 |
| Table 19. | SPI interface timing..... | 44 |
| Table 20. | Order codes | 45 |

List of figures

| | | |
|------------|---|----|
| Figure 1. | MCDP2900 block diagram..... | 8 |
| Figure 2. | MCDP2900 adaptor (dongle) use case | 10 |
| Figure 3. | MCDP2900 block diagram..... | 11 |
| Figure 4. | Power-up timing sequence | 15 |
| Figure 5. | Internal crystal oscillator operation | 16 |
| Figure 6. | Parasitic capacitance sources | 17 |
| Figure 7. | MCDP2900 BGA diagram | 25 |
| Figure 8. | EXT_RESETN Connection to MCDP2900 | 33 |
| Figure 9. | MCDP2900 package drawing..... | 34 |
| Figure 10. | Marking template | 36 |
| Figure 11. | Recommended Power supply connections for MCDP2900 | 38 |
| Figure 12. | I2C timing..... | 43 |

Features

- DisplayPort™ (DP) ver. 1.4a Link layer receiver
 - Up to 5.4Gbps Link rate supporting HBR2/HBR/RBR modes
 - 1, 2, or 4 lanes configuration
 - Programmable receiver equalization
 - Single Stream
 - AUX CH 1 Mbps
 - 3.3V HPD_OUT
 - Link Training (LT) enhancements as in DP1.4a specification
 - Supports eDP ASSR scrambler operation
 - Video Stream Handling
 - Up to 600MHz dual pixel path and 16bpc
 - RGB/ YCbCr 444/422/420 pixel format
 - Horizontal expansion of VESA CVT to CEA timings as per DP1.4a specification
 - DPCD and CEC
 - Supports DPCD data structure revision 1.4 as per DP1.4a specification
 - Supports CEC tunneling over AUX
 - DP to HDMI Stereoscopic 3D Transport
 - Frame Sequential to Stacked Top-Bottom Conversion
 - Pass-through of other 3D formats
 - Audio Stream handling
 - LPCM and Compressed Audio encoding formats
 - Max Audio sample rate of 192KHz x8 Channel or 768KHz x2 Channel
- HDMI ver. 2.0b transmitter
 - 600 MHz maximum TMDS character clock
 - DC-coupled outputs with source termination
 - TMDS character-clock divide_by_4 Mode
 - Scrambling over HDMI2.0b
 - Programmable edge rate control
 - Programmable pre-emphasis control
 - Deep color up to 16 bits per color
 - High Dynamic Range support (Static and Dynamic HDR)
 - 3D video timings
 - CEC support – snooping, tunneling
 - HPD_IN handling
 - SCDC read request handling
 - Polling enabled for HDMI sinks not supporting read requests
- Video Input Processing (up to 6Gbps)
 - Color space conversion
 - 10 bits per color input width
 - 12 bits per color output width
 - 16 bits per color pass through
 - Programmable coefficient 3x3 matrix
 - Programmable input offset
 - Programmable output offset
 - Programmable output clipping levels
- Chroma Down Sampling
 - 5-tap H & V FIR filters with programmable coefficients
 - 12 bits per color input width
 - 12 bits per color output width
 - YCbCr444 to YCbCr420 conversion
 - YCbCr444 to YCbCr422 conversion
 - YCbCr422 to YCbCr420 conversion
 - Bypass chroma down-sampling for YCbCr420 input over DP Link
- Max video resolution and color depth on HDMI TX output
 - 4Kp60Hz, RGB/YCbCr444, 8 bpc
 - 4Kp60Hz, YCbCr422 up to 12 bpc
 - 4Kp60Hz, YCbCr420, up to 16 bpc
 - 4Kp30Hz, RGB/YCbCr444, up to 16 bpc
- Audio stream forwarding from DP RX to HDMI TX
 - Up to 8-ch, 192 kHz, 24 bps LPCM audio, AC3, DTS, Dolby-HD
 - 2-ch, 768 kHz 24 bps HBR audio
- HDCP support

- HDCP1.3 to HDCP1.4 Repeater function
- HDCP2.3 to HDCP1.4 Repeater function
- HDCP2.3 to HDCP2.3 Repeater function
- Read-protected embedded HDCP keys
- Enhanced security
 - Encrypted on-chip key storage
 - Security signed application firmware
 - Secure boot-up procedure
 - Debug ports disabled in production
- Metadata handling
 - HDMI TX DVI/HDMI mode setting (DPCD register)
 - YCbCr444-420 conversion (DPCD register)
 - IEC60958 BYTE3 Channel Status overwrite
 - CEA861F INFOFRAME generation
 - CEA861.3 HDR and Mastering InfoFrame as per DP1.4a specification
- Device configuration options
 - 8Mbit SPI flash for firmware binary image storage
 - AUX CH, I2C host interface
- Internal video pattern generator
 - Configurable through DPCD registers
- EMI reduction support
 - Spread spectrum for DP input
 - Scrambler for DP input and HDMI output
- Low power operation
 - 570 mW in protocol converter operation
 - 11 mW sleep mode operation
- ESD specification
 - ESD: +/-2 KV HBM, 500 V CDM
 - ESD: +/-6.5 KV HBM connector facing pins
- Package
 - 64 LFBGA (7 x 7 mm)
- Power supply voltages
 - 3.3 V I/O; 1.2 V core

Applications

- Notebook, Tablet Accessories (USB Type-C dongles, docking stations)
- TV, Signage, Game consoles, STB

Figure 1. MCDP2900 block diagram

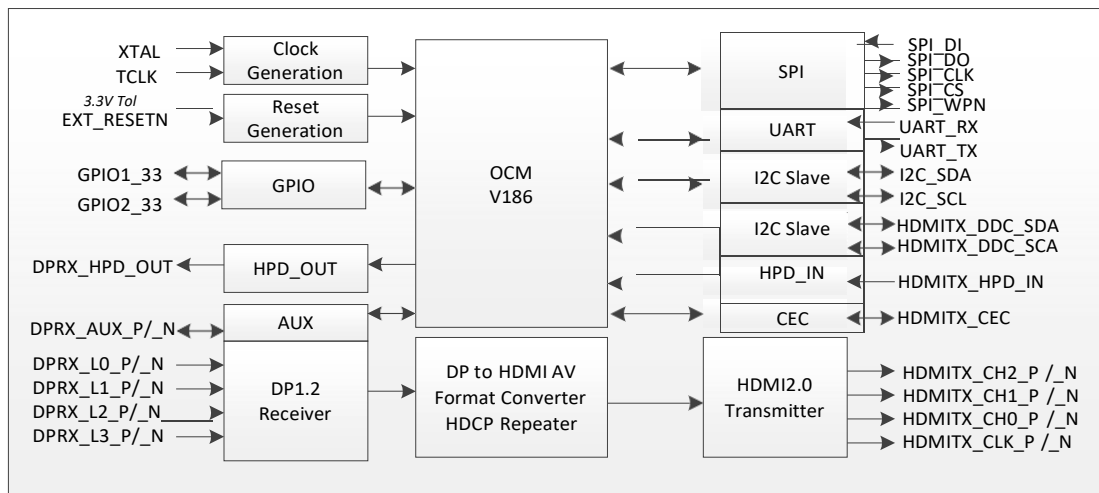

1. Description

The MCDP2900 is a power-optimized DisplayPort1.4a-to-HDMI2.0b converter, targeted for enabling USB Type-C DP Alt mode on TVs, Game consoles and other consumer equipment as well as for mobile PC and tablet accessory applications. This device functions as an active protocol converter with HDCP1.x/ HDCP2.3 repeater supporting HDR video quality for deep color media content playback.

MCDP2900 behaves as a DP branch device with a DP-to-HDMI transport protocol converter function and allows a DP or USB Type-C source to drive an HDMI sink device. The maximum TMDS character clock frequency supported is 600 Mchar/s (per HDMI2.0b specification).

The MCDP2900 operates with two power supply voltages: 1.2 V and 3.3 V. It consumes:

- 570 mW in protocol converter operation
- 11 mW sleep mode operation

The MCDP2900 has a DP1.4a receiver and an HDMI2.0b transmitter. The DP receiver supports up to 5.4Gbps/lane over 4 lanes. It supports DP SST transport format on its main link and Manchester-coded AUX signaling as the side band channel. The downstream HDMI TX port is HDMI2.0b specification compliant.

The MCDP2900 is capable of supporting Ultra High-Definition video formats with resolutions as high as 4096 x 2160 progressive @ 60 Hz (4K2Kp60Hz). It supports RGB/YCbCr video color formats with a color depth of 16 bpc (bits per component or 48 bits per pixel) as long as it fits within the DP and HDMI link bandwidth.

This device also supports pixel encoding conversion from RGB or YCbCr444 to YCbCr420 and a YcbCr420 pass-through function. In addition, High Dynamic Range (HDR) with deep color up to 12bpc at 4Kp60Hz is supported through the conversion of RGB/YCbCr444 over DP link to YCbCr420 on the HDMI output with a horizontal expansion to CEA timings.

This device offers secure reception and transmission of high bandwidth digital audio and video content with HDCP1.3 and HDCP2.3 content protection for the upstream DP interface. It also supports HDCP1.4 and HDCP2.3 repeater function compliant to the latest CTS specification.

The MCDP2900 uses an external crystal of 27 MHz as a reference clock for its operation. An internal Power On Reset (POR) circuit senses the voltage on the reset input and provides the chip reset during system power-up. The device has an internal microcontroller with SPI, UART (debug only), and I2C system interface signals. It uses an external 8Mbit SPI flash memory for storing a secure signed firmware image with fail-safe recovery. Firmware update to the SPI flash is done securely through the DP AUX_CH or the I2C host interface. The secure programming (In-System-Programming), secure boot and application FW signing process uses RSA 2048-bit root and leaf public/private key pairs.

2. Application overview

The target applications of MCDP2900 are the notebook, tablet accessories i.e., adaptors (dongles), docking stations and other AV accessories. MCDP2900 is also intended for enabling USB Type-C DP alternative mode for inside-the-box applications such as TVs, game consoles and other consumer equipment.

2.1. Adaptor application

In a dongle topology the MCDP2900 is part of the source side adaptor that plugs into a DP source device via a DisplayPort connector (e.g. full-size DP or mini-DP receptacle or USB-Type-C Alt-Mode receptacle on the upstream facing port). In the conventional DP-to-HDMI dongle application, MCDP2900 functions as a system master and operates as a protocol converter, an HDCP1.x repeater or an HDCP2.3 repeater. In a Type-C dongle design, a PD controller functions as the system master. The upstream source typically powers the dongle.

Figure 2. MCDP2900 adaptor (dongle) use case

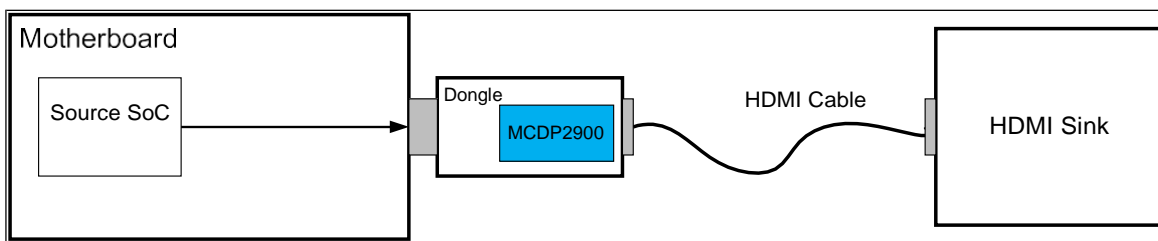

2.2. Docking station application

In a docking station topology, the MCDP2900 is part of a larger system into which a DP source device plugs in via a custom connector or USB-Type-C Alt-Mode receptacle on the upstream facing port. In a docking station design the MCDP2900 typically co-exists with other system components such as the system host or PD controller, AV switch, and USB hub. In this application, the MCDP2900 functions as a protocol converter, an HDCP1.x repeater, or an HDCP2.3 repeater.

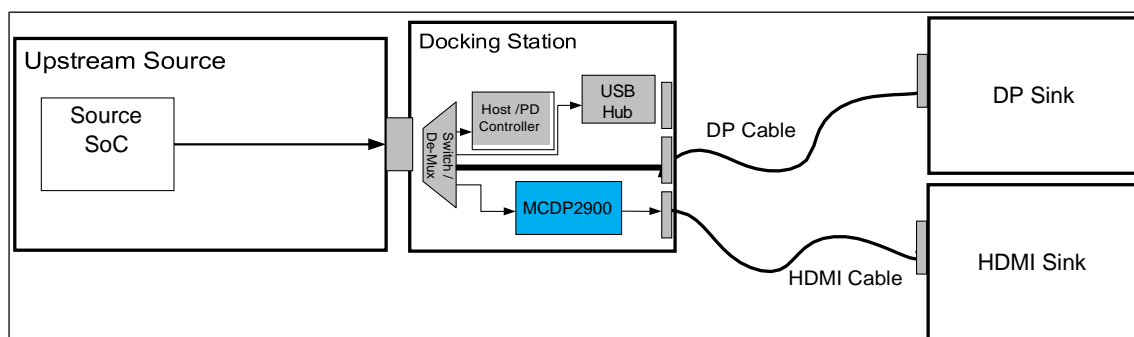

2.3. TV Application

A TV system featuring the USB Type-C connector supporting the DP Alt-mode requires a DP-to-HDMI protocol converter. The MCDP2900 is an ideal fit for such applications; it supports video resolution up to 4K60Hz with HDR video quality for deep color media playback, end-to-end HDCP2.3 content protection, and CEC tunneling over DP for single-point remote-control access for all connected devices.

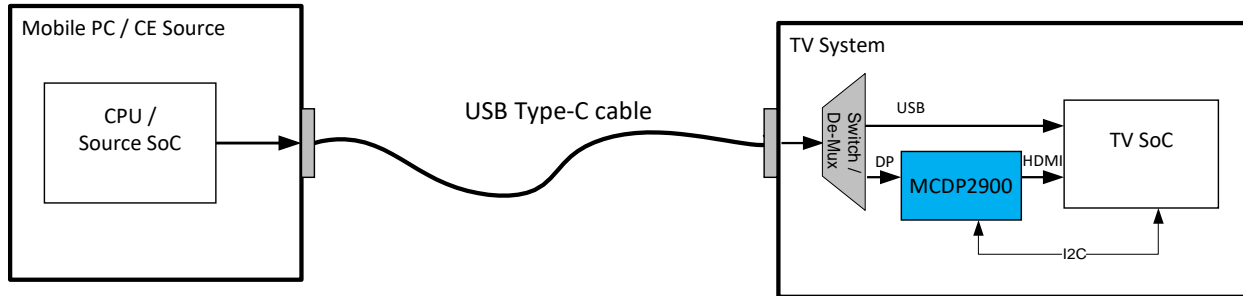

3. System block diagram

Figure 3. MCDP2900 block diagram

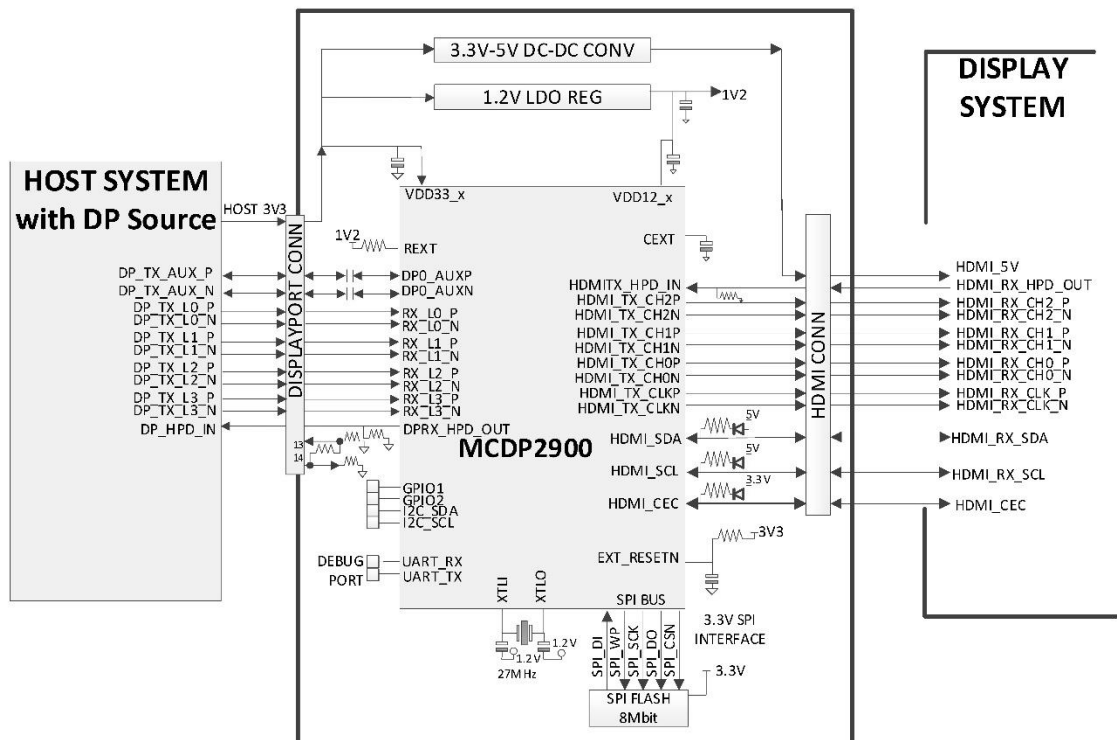

4. Interface description

4.1. Input interface

The MCDP2900 receives audio-video streams from a source device via the DP1.4a link supporting a main link configuration of up to 4 lanes (and up to 5.4Gbps/lane) with 0.5% down-spread option. The DP link consists of 4 main lanes, AUX CH, and a DP_HPD signal.

Both the main link receiver and AUX CH transceiver are internally terminated to the 1.2 V power rail. The AC-coupling capacitors for the AUX signals shall be placed externally. The DP_HPD signal is a 3.3V TTL signal set to “1” when MCDP2900 is ready to handle an AUX request transaction. An external pull down resistor of 100 Kohm shall be used. The power for MCDP2900 can be provided by a DP source device, DP_PWR on a DP connector, or from the USB Type-C connector, or by an external supply.

MCDP2900 supports both native AUX transaction syntax and I2C-over-AUX transaction syntax. With I2C-over-AUX transactions, a DP source can access the downstream EDID. EDID larger than 256 bytes can be accessed by using segmented addressing mechanism specified in the E-DDC standard.

The MCDP2900 supports link training with AUX transactions as specified in DP1.4a. The usage of TPS4 (Training Pattern Sequence 4) added to DP1.4a is recommended to optimize both DPTX PHY drive setting of DP source and its own DPRX EQ setting. If a DP source does not support TPS4, support of the POST_LT_ADJ_REQ procedure as defined in DP1.4a is recommended. Once the DP source has performed link training, but later stops the main link signal transmission (for example, transitioning to the power saving state with DPCD 00600h set to 02h), MCDP2900 requires another full link training to re-establish the link. MCDP2900 also supports the new link training policy defined for DP alternative mode sources. In this policy, the lane count is reduced to match the number of lanes physically connected based on the DPCD clock recovery status register [LANEx-CR_DONE].

By default, the firmware keeps DP_HPD asserted unless it is in OFF power state, regardless of whether HDMI_HPD input is asserted or not. The HDMITX_HPD input status is reflected on SINK_COUNT value at DPCD 00200h. The value is 1 when the HDMITX_HPD input is asserted, and 0 when de-asserted.

Whenever MCDP2900 detects HDMI_HPD input status change, it generates IRQ_HPD on the DP_HPD line.

4.1.1. Video stream regeneration

The MCDP2900 is capable of regenerating an incoming video stream from a DP source up to 600Mpixels/sec and 16 bits per component / 48 bits per pixel, as long as the video stream bandwidth fits within the link bandwidth.

4.1.2. Horizontal blanking expansion

MCDP2900 supports VESA CVT horizontal reduced blanking to CEA-861-F conversion up to 4Kp60Hz video timing format.

4.1.3. On-chip video pattern generation

MCDP2900 has an on-chip pattern generator controlled by vendor-specific DPCD Addresses 00579h ~ 0057Bh.

4.1.4. Audio stream regeneration

The DP receiver is capable of regenerating 2-ch audio up to 768 kHz, and 8-ch audio up to 192 kHz, with the sample bit depth of 16, 20, and 24 bits per sample.

4.1.5. HDCP RX

MCDP2900 supports HDCP1.3 and HDCP2.3 for DP. The HDCP RX key sets are stored in a secure on-chip OTP memory.

4.2. Output interface

The MCDP2900 outputs audio-video streams in DC-coupled (3.3 V level) TMDS format to the downstream HDMI connector. The HDMI transmitter in MCDP2900 is compliant with both HDMI1.4 and HDMI2.0b specifications.

4.2.1. HDMI transmitter

The HDMI output port consists of 3 data pairs, a clock pair, a DDC channel, HDMI_HPD signal and CEC signal. The maximum data rate on this link is 6.0 Gbs per channel. Both data and clock channels shall be terminated to 3.3 V by the downstream HDMI receiver. MCDP2900 autonomously controls both TMDS character clock divide by 4 and scrambling as defined by HDMI2.0b. Differential voltage swing, pre-emphasis, edge rate, and source termination can be controlled by vendor-specific DPCD registers.

The HDMI TX PHY is capable of generating three PHY test patterns selectable by DPCD registers.

The HDMI_HPD input signal shall be directly connected to the downstream HDMI_HPD from the HDMI connector.

The HDMI CEC feature is supported by MCDP2900 as defined in the DP1.4a specification. CEC commands between downstream HDMI device and upstream DP source device are tunneled through DP AUX_CH.

4.2.2. HDCP TX

MCDP2900 supports HDCP1.4 and HDCP2.3 content protection. It functions as an HDCP1.x and HDCP2.3 repeater. The HDCP key sets are stored in a secure on-chip OTP memory.

4.2.3. DDC master

The HDMI TX has a DDC master that supports EDID reads, MCCS and SCDC read requests. The DDC channel is a 5 V, open-drain signal; it requires an external diode termination with a 2.2 K Ω series resistor to a 5 V supply. No more than 10 μ A of current per DDC pad is drawn when the DDC lines are pulled up to 5.5 V while the chip is powered off. The DDC data rate is selected in the range of 1 kbps to 100 kbps, with 50 kbps being the default rate, by DPCD address 00109h.

MCDP2900 reads the HDMI RX link error status once every 100 ms and updates the HDMI link error status registers at DPCD 03031h ~ 03033h. An IRQ_HPDP is generated with any HDMI_LINK_STATUS_CHANGE.

4.2.4. HDMITX_HPDP

MCDP2900 monitors the HDMI_HPDP status unless it is in the OFF power state and updates the SINK_COUNT DPCD register value at DPCD Address 00200h. The value is 1 when HDMI_HPDP is asserted and 0 when HDMI_HPDP is de-asserted. Upon the HDMI_HPDP status change, the chip generates an IRQ_HPDP on DP_HPDP line with the SINK_COUNT value updated.

HDMITX_HPDP_IN pin shall have a 20k pull-down resistor. No more than 10 μ A of current pad is drawn by HDMITX_HPDP_IN pin when it is pulled up by the sink to 5.5 V while the chip is powered off.

4.2.5. CEC

The MCDP2900 supports tunneling CEC commands as defined in the DP1.4a specifications. In addition, CEC snooping and multiple logical address capability are supported. The CEC pin is connected to a 3.3 V open drain pad. No more than 10 μ A of pad current is drawn while the chip is powered off.

4.3. Chip power-up sequence and reset

The figure below shows the power-up timing sequence requirements of the 3.3 V and 1.2 V power rails and the internal reset signal.

During rail power up, the voltage (pull-up resistor to 3.3 V supply) on EXT_RESEn pin is sensed by the internal Power-On Reset (POR) circuit to generate an internal reset pulse. The internal reset pulse is low until both the 3.3 V and 1.2 V rails are stable. The internal reset pulse continues to stay low for at least 1 ms after the 1.2 V power rail reaches 0.8 V. During the device power up, the 3.3 V supply shall lead the 1.2 V supply ($VDD33 \geq VDD12$ for $t > 0$).

Figure 4. Power-up timing sequence

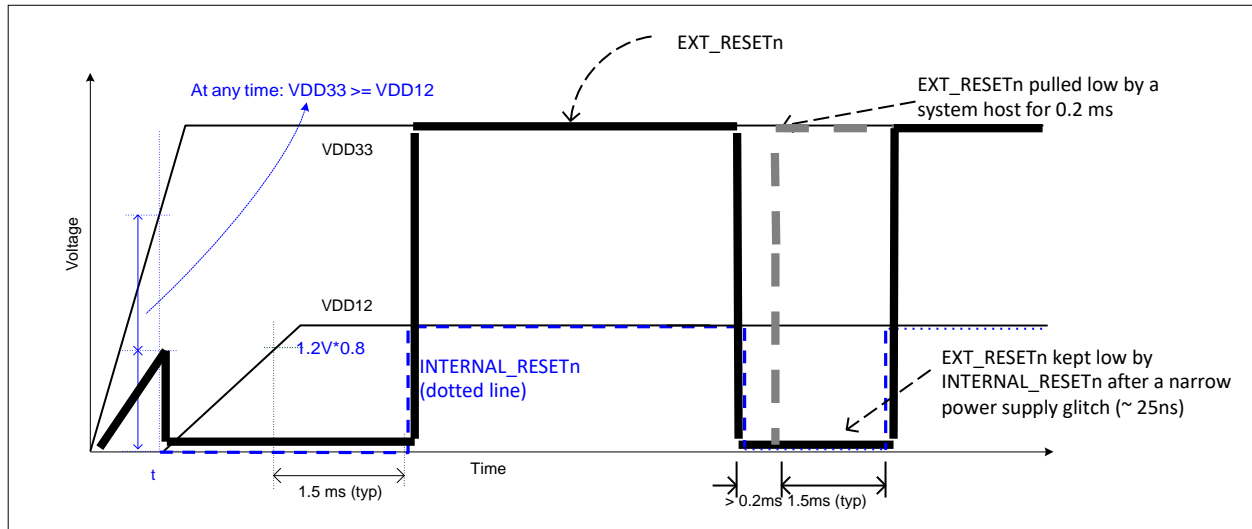

Any time a power supply glitch causes the power rails to fall below 2.7 V (for 3.3 V power rail) and below 0.8 V (for 1.2 V power rail), the internal reset signal drops and stays low for at least 1 ms after the 1.2 V power rail reaches 0.8 V again.

An external reset signal (active low) can be applied to the EXT_RESEn pin. This shall be driven by an Open-Drain Output.

4.4. Clock generation

The 27 MHz TCLK is the main timing clock for this device. All other internal clocks are generated from the TCLK. The internal TCLK oscillator generates TCLK when a crystal is attached as shown in the figure below.

Figure 5. Internal crystal oscillator operation

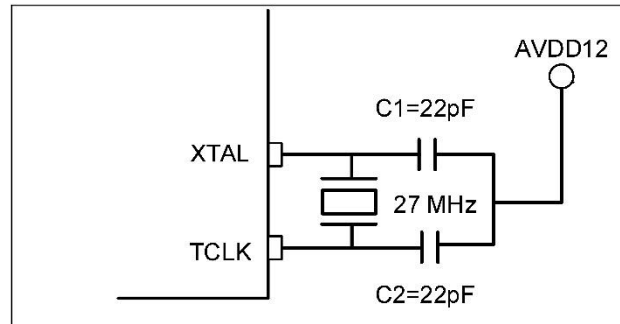

4.4.1. Internal crystal oscillator operation

A crystal is connected between the XTAL pin and the TCLK pin with the external capacitors (C1 and C2) to match the proper value of loading capacitance specified in crystal specification.

Note: The value of C1 and C2 are determined based on the loading capacitance from the crystal specification and by compensating for the parasitic capacitance of the device and the printed circuit board traces. The external capacitors are terminated to the Analog 1V2 power supply. This connection increases the power supply rejection ratio when compared to terminating the loading capacitors to ground.

The external capacitors' value used with the crystal (shown below) is an important design parameter. The loading capacitance (Cload) on the crystal is the combination of C1 and C2 and is calculated by $C_{load} = ((C1 * C2)/(C1 + C2)) + C_{shunt} + C_{parasitic}$. The shunt capacitance Cshunt is the effective capacitance between the XTAL and TCLK pins. Refer to crystal specification for the proper Cshunt value. The Parasitic capacitance is the combination of the PCB board capacitance (Cpcb), the pin capacitance (Cpin), the pad capacitance (Cpad), and the ESD protection capacitance (Cesd). The overall parasitic capacitance is 2-3pF range for MCDP2900 design.

Figure 6. Parasitic capacitance sources

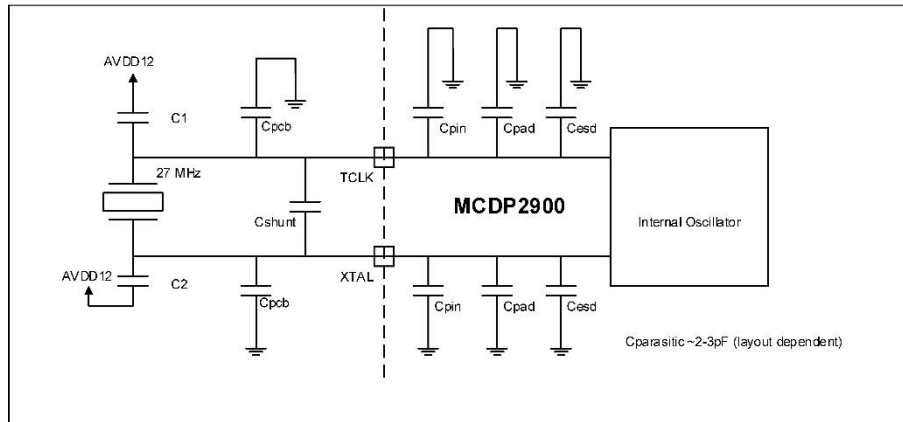

Note these details of the oscillator circuit when used with a crystal resonator:

- The PCB traces should be as short as possible.
- The crystal should be a parallel resonate-cut

4.4.2. Crystal specifications

While the selection of a crystal mainly depends on the specific PCB layout and the crystal manufacturer's specifications, the following are general recommendations.

Table 1. Crystal specifications

| Parameters | Specifications |
|----------------------------|------------------|
| Frequency | 27.000 MHz |
| Operation Mode | Fundamental |
| Operating Temperature | -10 °C to +70 °C |
| Frequency Tolerance @ 25°C | +/- 50 ppm max |

5. Chip operation

5.1. Initial state

Upon power-up or after reset, the On-Chip Micro of MCDP2900 does the device configuration. After the initial system setup and configuration, the IROM firmware performs a validation of the signed application code image stored in the external SPI flash memory (a.k.a. secure boot process) and copies this code image into internal memory. Upon successful validation, the application code image executes from the internal memory. For security reasons further access to the external SPI-Flash memory is blocked. If code image validation fails, execution from IROM continues in a tight loop until reset or power off.

5.2. Video pixel processing

MCDP2900 embeds a video pixel processing unit which is capable of color space conversion with bit-depth expansion (pixel encoding format changing) and horizontal and vertical Chroma down sampler (pixel decimation). The decoded video stream from the DP receiver can either go through the pixel processor or fully bypassed before being encoded in to TMDS format by the HDMI transmitter. The DP source sets the DPCD address 03051h -03052h for enabling or disabling of the color space conversion and Chroma down-sampling in MCDP2900.

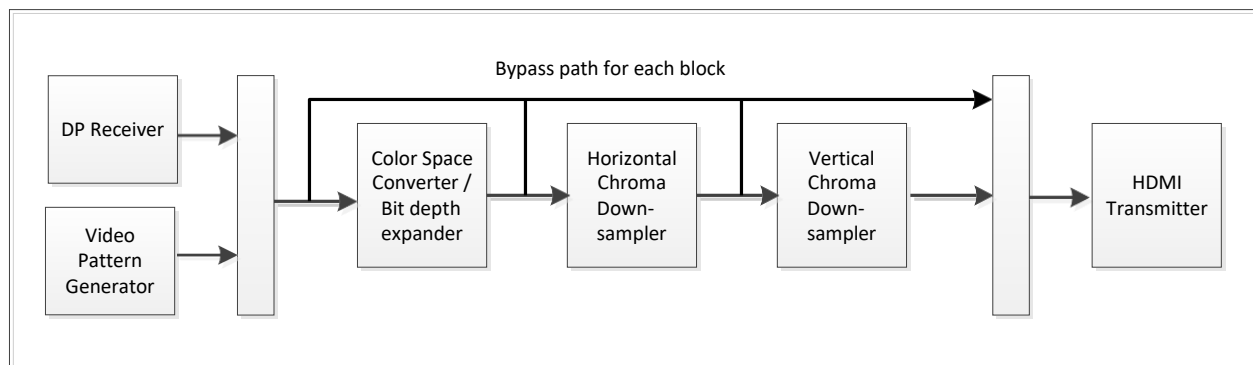

5.2.1. Color Space Converter

The Color Space Converter block receives video in RGB444 format with 10 bits per component (30 bits per pixel) from the DPRX unit or from the on-chip video pattern generator. It outputs video in YCbCr444 format with 12 bits per component. The CSC is a 3x3 matrix with programmable coefficients and an offset option. The default setting uses ITU-R BT.601 coefficients. The customer can choose to overwrite the default setting with ITU-R BT.709 or ITU-R BT.2020 coefficients through vendor specific DPCD registers.

The 12-bit output of the CSC can be 12.0, 10.2, or 8.4 format - 12 integer bits data or 10 integer bits plus 2 zero-padding (or most significant 2 bits padding), or 8 integer bits plus 4 zero-padding bits. This CSC block configuration is performed through CSC_CONTROL1 and CSC_CONTROL2 registers in the vendor specific DPCD address space.

5.2.2. Horizontal Chroma Down-Sampler

Horizontal Chroma Down-Sampler receives 12 bits per component video in YCbCr444 format from the CSC block and outputs 12 bits per component in YCbCr422 or YCbCr420. It also supports YCbCr422 to YCbCr420 conversion. The 12-bit output can be 12.0, 10.2, or 8.4 format - 12 integer bits data or 10 integer bits plus 2 zero-padding (or most significant 2 bits padding), or 8 integer bits plus 4 zero-padding bits. This Horizontal Chroma Down-Sampler block configuration is done through vendor specific DPCD registers.

5.2.3. Vertical Chroma Down-Sampler

Vertical Chroma Down-Sampler receives 12 bits per component either from CSC block or from Horizontal Chroma Down-Sampler, and outputs 12 bits per component in YCbCr422 or YCbCr422 format. Similar to Horizontal Chroma Down-Sampler the output of this block can be 12-bit in 12.0, 10.2, or 8.4 format and the configuration is done through the vendor specific DPCD registers.

The video pixel data from the video pixel processing unit is rounded to the integer number before it is sent to the HDMI TX video interface block.

5.3. Power management

The MCDP2900 uses 3.3 V and 1.2 V power supplies. In a dongle application, MCDP2900 receives the 3.3V power supply from the DP source. The 1.2 V supply is generated from 3.3 V using an on-board 1.2 V (LDO or SMPS) regulator. In other applications the 3.3V and 1.2V are supplied by the on system PMIC. The DP source puts MCDP2900 into a sleep state writing 02h to DPCD 00600h. During sleep state, all internal PLL and clock sources are either turned off or run at a reduced frequency. Additionally, Analog blocks are also put to sleep mode operation or disabled.

Table 2. MCDP2900 power saving states

| Items | Sleep state |
|--|-----------------------|
| EXTENDED_DPRX_SLEEP_WAKE_TIMEOUT_GRANT DPCD register setting (at DPCD Address 00119h) | 00h |
| Conditions in the power saving state | |
| Power consumption | 11 mW typical |
| TCLK | Remains running |
| DP_HPD | Remains asserted |
| GPIO's | Retain states |
| Registers | Retains states |
| AUX request transaction | Monitored |
| HDMI_HPD | Monitored |
| CEC | Monitored |
| Entry | |
| Trigger event | DPCD 00600h = 02h |
| Exit events and ensuing actions | |
| AUX request transaction from a DP Source | Ready to reply in 1ms |

| Items | Sleep state |
|--|---|
| HDMI_HPD level change | Reports to a DP Source via IRQ_HPD in 1ms |
| CEC signal level change | Handles message and generates IRQ_HPD to a DP Source in 1ms |
| EXT_RESETN pulse assertion and/or 1.2V and/or 3.3V power rail disruption | Results in chip reset |

5.4. HDCP operation

The HDCP1.x TX and RX key sets are scrambled and stored in the on-chip OTP memory. Also HDCP2.3 data (RX private key, RX device certificate, and Ic128) are encrypted and stored in the on-chip OTP memory. The table below shows the HDCP operations of MCDP2900, based on the capabilities of an upstream DP source and a downstream HDMI sink. A DP source device shall not transmit a content type that the downstream HDMI devices are not qualified to receive. If the DP source does, the MCDP2900 blocks the stream retransmission. Instead MCDP2900 transmits a constant-pixel image as selected by a branch vendor-specific DPCD register with the video timing format from the DP source device. In case the DP source is transmitting an audio stream, MCDP2900 sets the AVMUTE bit in the General Control Packet (GCP) and stops the transmission of Audio Sample Packets.

As for the periodic Ri' (or Rx Status) read over an HDMI link, MCDP2900 uses by default a "long read". That is, I2C writes to set the offset followed by an I2C read to read the Ri' or Rx Status value in a single I2C transaction having a Repeated Start condition. A DP source device may prompt MCDP2900 to conduct a "short read" of Ri' for the HDCP1.4 operation via branch vendor-specific DPCD register.

Table 3. HDCP operations of MCDP2900

| DP source capability | HDMI downstream device capability | HDCP repeater operation | Notes |
|----------------------|-----------------------------------|-------------------------|--|
| HDCP1.3 only | HDCP1.4 only | YES | |
| HDCP1.3 only | HDCP2.3 | NO | A DP Source device shall not transmit “HDCP2.3 Type 1” content over a DP link with HDCP1.3 content protection |
| HDCP2.3 | HDCP1.4 only | YES | MCDP2900 shall retransmit only HDCP2.3 Type 0 content; in case the DP Source transmits HDCP2.3 Type 1 content, MCDP2900 shall transmit a constant pixel image from its on-chip video pattern generator |
| HDCP2.3 | HDCP2.3 | YES | |

If the HDCP link integrity failures with a downstream HDMI device persist, the CP_IRQ bit is set, and an IRQ_HPDPulse is generated to the DP source device to prompt an HDCP re-authentication.

Upon detecting a hot unplug/plug event of the downstream HDMI sink, IRQ_HPDPulse is generated with the updated SINK_COUNT value at DPCD 00200h and HDCP re-authentication occurs.

5.5. CEC tunneling over AUX

MCDP2900 fully supports CEC tunneling-over-AUX, including snooping, multi-logical address, and HDMI_HPDPulse monitoring features as described in Section 5.3.3.3.1 of the DP1.4a Specification.

In the sleep state, the chip continues to monitor CEC signal activity and exits the sleep state upon the detection of a signal transition. However, the first block (which is a Header Block) that causes the sleep state exit can be missed. If the CEC message that causes the sleep state exit has the CEC logical address corresponding to one of the CEC Logical Address Mask values, the initiator of the CEC message is required to retry as per HDMI CEC Specification.

6. System interface

The MCDP2900 has the following system interfaces:

- I2C slave interface
- SPI interface
- UART interface

6.1. I2C interface

The I2C slave interface is intended for monitoring and configuring certain registers of the MCDP2900 from a host controller in a system. For example, in a type-C docking station system the PD controller may use this interface to check the MCDP2900 power-ON status and for downloading firmware. Refer to the MCDP2900 host interface register listing for the detailed description of the supported registers and In-system-Programming (ISP) user guide for implementing firmware download from the host controller. The I2C device ID used for host communication is E0h/E1h.

6.2. SPI interface

The MCDP2900 has an SPI interface for connecting external program flash memory (SPI Flash device). The typical clock speed for the SPI interface is 50 MHz. The required SPI Flash ROM size is 8 MBits for storing the application firmware code image with dual-bank option for fail-safe. The SPI flash is programmed via the DisplayPort AUX interface or host I2C interface. Kinetic provides the In-system-Programming (ISP) tool and the driver for programming the SPI flash ROM. Contact Kinetic for the list of SPI flash devices supported in the ISP driver. The SPI interface between MCDP2900 and a serial flash ROM is as follows. All signals of the SPI interface are LVTTTL (3.3 V):

- SPI_CSN: SPI chip select signal; connect to CE# of SPI flash ROM
- SPI_WP: SPI write protect signal; connect to WP# of SPI flash ROM
- SPI_DO: SPI data output from MCDP29x0; connect to SPI_DI of SPI flash ROM
- SPI_DI: SPI data input to MCDP29x0; connect to SPI_DO of SPI flash ROM
- SPI_CLK: SPI clock signal; connect to SPI_SCK of the SPI flash ROM

6.3. UART interface

The UART interface is used only during product development for firmware programming, testing, and debugging purpose. For security reasons, the UART interface is blocked in the production version of the

silicon. All UART signals are LVTTTL (3.3 V) level. The UART interface supports a maximum baud rate of 115k-baud.

6.4. GPIO interface

The GPIO interface consists of 4 pins (GPIO1_33, GPIO2_33, I2C_SDA, and I2C_SCL) which may be configured and used by application firmware.

6.5. Locking of system interfaces

MCDP2900 hardware locks the UART interface for enhanced security. Also, the SPI interface is locked after successful completion of the secure boot up.

7. BGA footprints and pin list

The ball grid array (BGA) diagrams give the allocation of pins to the package, shown from the top looking down using the PCB footprint.

Some signal names in BGA diagrams have been abbreviated. Refer to the pin list for full signal names sorted by pin number.

Figure 7. MCDP2900 BGA diagram

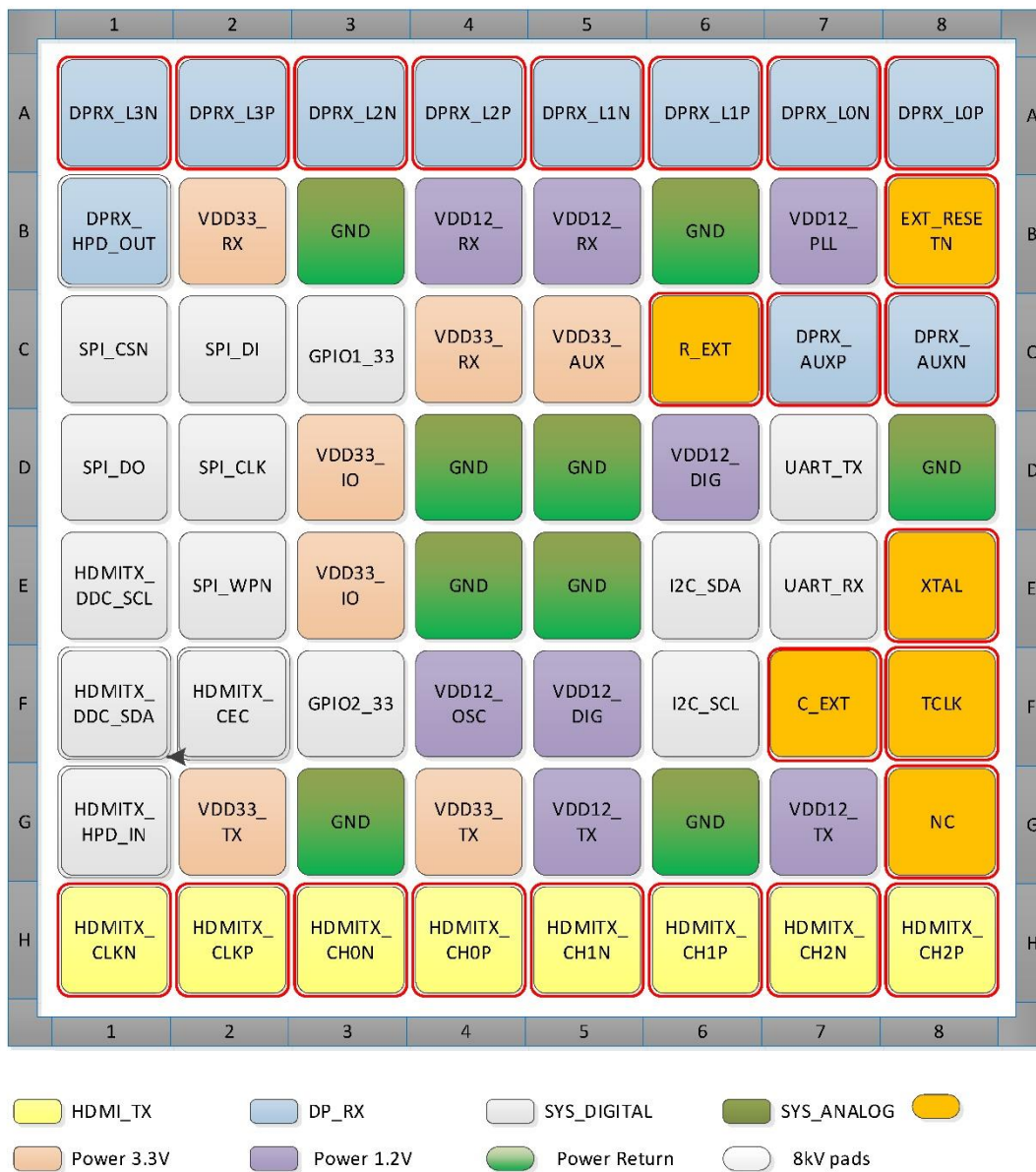

Reference: bobcat_pinlist_ballmap.xlsx revision 1r5 dated June 3, 2013

7.1. Signal mapping sorted by ball (pin) number

Table 4. Pin list

| Pin number | Net name |
|------------|--------------|
| A1 | DPRX_L3N |
| A2 | DPRX_L3P |
| A3 | DPRX_L2N |
| A4 | DPRX_L2P |
| A5 | DPRX_L1N |
| A6 | DPRX_L1P |
| A7 | DPRX_L0N |
| A8 | DPRX_L0P |
| B1 | DPRX_HPD_OUT |
| B2 | VDD33_RX |
| B3 | GND |
| B4 | VDD12_RX |
| B5 | VDD12_RX |
| B6 | GND |
| B7 | VDD12_PLL |
| B8 | EXT_RESETN |
| C1 | SPI_CSN |
| C2 | SPI_DI |
| C3 | GPIO1_33 |
| C4 | VDD33_RX |

| Pin number | Net name |
|------------|----------------|
| C5 | VDD33_AUX |
| C6 | R_EXT |
| C7 | DPRX_AUXP |
| C8 | DPRX_AUXN |
| D1 | SPI_DO |
| D2 | SPI_CLK |
| D3 | VDD33_IO |
| D4 | GND |
| D5 | GND |
| D6 | VDD12_DIG |
| D7 | UART_TX |
| D8 | GND |
| E1 | HDMITX_DDC_SCL |
| E2 | SPI_WPN |
| E3 | VDD33_IO |
| E4 | GND |
| E5 | GND |
| E6 | I2C_SDA |
| E7 | UART_RX |
| E8 | XTAL |
| F1 | HDMITX_DDC_SDA |
| F2 | HDMITX_CEC |
| F3 | GPIO2_33 |

| Pin number | Net name |
|------------|---------------|
| F4 | VDD12_OSC |
| F5 | VDD12_DIG |
| F6 | I2C_SCL |
| F7 | C_EXT |
| F8 | TCLK |
| G1 | HDMITX_HPD_IN |
| G2 | VDD33_TX |
| G3 | GND |
| G4 | VDD33_TX |
| G5 | VDD12_TX |
| G6 | GND |
| G7 | VDD12_TX |
| G8 | NC |
| H1 | HDMITX_CLKN |
| H2 | HDMITX_CLKP |
| H3 | HDMITX_CH0N |
| H4 | HDMITX_CH0P |
| H5 | HDMITX_CH1N |
| H6 | HDMITX_CH1P |
| H7 | HDMITX_CH2N |
| H8 | HDMITX_CH2P |

8. Connections

8.1. Pin list

I/O Legend: I = Input; O = Output; P = Power; G = Ground; I/O = Bi-direction; AI = Analog Input

Note: Some pins can have multiple functionalities, which are configured under register control. The alternate functionality for each pin is listed in the Description column.

Table 5. DisplayPort receiver pins

| Pin | Assignment | I/O | VDD Domain | Description |
|-----|---------------|-----|------------|--|
| A1 | DPRX_L3N | I | 1.2V | DisplayPort receiver main link Lane 3 negative analog input. Main Link receiver pins (DPRX_LxN or DPRX_LxP where N = 0 ~ 3) and AUX CH pins of MCDP2900 are internally terminated to 1.2V power rail. Therefore external AC-coupling capacitors are required for DPRX Main Link and AUX CH pins. |
| A2 | DPRX_L3P | I | 1.2V | DisplayPort receiver main link Lane 3 positive analog input. |
| A3 | DPRX_L2N | I | 1.2V | DisplayPort receiver main link Lane 2 negative analog input. |
| A4 | DPRX_L2P | I | 1.2V | DisplayPort receiver main link Lane 2 positive analog input. |
| A5 | DPRX_L1N | I | 1.2V | DisplayPort receiver main link Lane 1 negative analog input. |
| A6 | DPRX_L1P | I | 1.2V | DisplayPort receiver main link Lane 1 positive analog input. |
| A7 | DPRX_L0N | I | 1.2V | DisplayPort receiver main link Lane 0 negative analog input. |
| A8 | DPRX_L0P | I | 1.2V | DisplayPort receiver main link Lane 0 positive analog input. |
| C7 | DPRX_AUXP | I/O | 3.3V | DisplayPort receiver auxiliary channel positive analog input/output. |
| C8 | DPRX_AUXN | I/O | 3.3V | DisplayPort receiver auxiliary channel negative analog input/output. |
| B1 | DPRX_HPDP_OUT | O | 3.3V | To the upstream HPD signal pin (DP source), to be externally pulled down (100K Ω). |
| C6 | R_EXT | I/O | 1.2V | Termination calibration reference resistor; 249 Ω 1% resistor must be connected from this pin to VDD12_RX. |

Table 6. HDMI output pins

| Pin | Assignment | I/O | VDD Domain | Description |
|-----|---------------|-----|--------------|---|
| H1 | HDMITX_CLKN | O | 3.3V | HDMI transmitter CLOCK_N to TX connector. |
| H2 | HDMITX_CLKP | O | 3.3V | HDMI transmitter CLOCK_P to TX connector. |
| H3 | HDMITX_CH0N | O | 3.3V | HDMI transmitter DATA0_N to TX connector. |
| H4 | HDMITX_CH0P | O | 3.3V | HDMI transmitter DATA0_P to TX connector. |
| H5 | HDMITX_CH1N | O | 3.3V | HDMI transmitter DATA1_N to TX connector. |
| H6 | HDMITX_CH1P | O | 3.3V | HDMI transmitter DATA1_P to TX connector. |
| H7 | HDMITX_CH2N | O | 3.3V | HDMI transmitter DATA2_N to TX connector. |
| H8 | HDMITX_CH2P | O | 3.3V | HDMI transmitter DATA2_P to TX connector. |
| E1 | HDMI_DDC_SCL | O | 3.3V, 5V TOL | HDMI TX DDC I2C master SCL. 3.3 V logic level, 5 V tolerant. Open drain, to be externally pulled up to DDC5V via a 1.5K ~ 2.2K Ω resistor. |
| F1 | HDMI_DDC_SDA | I/O | 3.3V, 5V TOL | HDMI TX DDC I2C master SDA. 3.3 V logic level, 5 V tolerant. Open drain, to be externally pulled up to DDC5V via a 1.5K ~ 2.2K Ω resistor. |
| F2 | HDMITX_CEC | I/O | 3.3V, 5V TOL | CEC input. 3.3 V open drain IO. Connect to HDMI CEC pin, to be externally pulled up to 3.3 V via 27K Ω resistor as per HDMI1.4b specification. Use weak external pull up or pull down (recommended 100K Ω) when CEC is not used. |
| G1 | HDMITX_HDP_IN | I | 3.3V, 5V TOL | 3.3 V logic level, 5 V tolerant input from HDMI connector. To be externally pulled down via 20K Ω resistor. |

Note: HDMI TX output is terminated at the receiver through a 50 ohm resistor.

Table 7. System interface pins

| Pin | Assignment | I/O | VDD Domain | Reset State | Description |
|-----|------------|-----|------------|--------------------|--|
| B8 | EXT_RESETN | I | 3.3 V | Input | Power-ON chip reset (active low) input signal, to be pulled up to 3.3V power rail via 2.2K Ω +/- 10% resistor as shown in Figure 8. |
| E8 | XTAL | I/O | 1.2V | NA | Connect to 27MHz crystal with 22pF to VDD12_OSC. |
| F8 | TCLK | I/O | 1.2V | NA | Connect to 27 MHz crystal with 22pF to VDD12_OSC. |
| F7 | C_EXT | O | 3.3V | NA | Capacitor for filtering internal 2.5V LDOR. Connect to GND through 2.2uF capacitor. |
| G8 | NC | O | 3.3 V | NA | Leave as NC |
| E6 | I2C_SDA | IO | 3.3 V | Input, Internal PU | Host I2C interface data line up to 400kbps. Programmable Slew Rate and Drive Strength when this is being used as a GPIO. |
| F6 | I2C_SCL | I | 3.3 V | Input, internal PU | Host I2C interface clock line up to 400 kbps. Programmable Slew Rate and Drive Strength when this is being used as a GPIO. |
| C3 | GPIO1_33 | IO | 3.3 V | Input, Internal PD | 3.3V General purpose input/output with programmable slew rate and drive control. Internal PD 50K Ohm. |
| F3 | GPIO2_33 | I/O | 3.3V | Input, internal PD | 3.3V General purpose input/output with programmable slew rate and drive control. Internal PD 50K Ohm. |
| C1 | SPI_CSN | O | 3.3 V | Input, Internal PU | Serial peripheral interface chip select. Programmable Slew Rate and Drive Strength. |
| C2 | SPI_DI | I | 3.3 V | Input, Internal PD | Serial peripheral interface data input. |
| D1 | SPI_DO | O | 3.3 V | Input, Internal PD | Serial peripheral interface data output. Programmable Slew Rate and Drive Strength. |
| D2 | SPI_CLK | O | 3.3 V | Input, Internal PD | Serial peripheral interface clock. Programmable Slew Rate and Drive Strength. |
| E2 | SPI_WPN | O | 3.3 V | Input, Internal PU | Serial peripheral interface write protect. Programmable Slew Rate and Drive Strength. |
| D7 | UART_TX | O | 3.3 V | Input, Internal PU | Universal asynchronous serial Tx output. Programmable Slew Rate and Drive Strength. |
| E7 | UART_RX | I | 3.3 V | Input, Internal PU | Universal asynchronous serial Rx input. Internal PU can be changed to Internal PD by register program. |

Table 8. Power and ground pins

| Pin | Assignment | Voltage Level | Description |
|---------------------------------------|------------|---------------|-------------------------------|
| B2, C4 | VDD33_RX | 3.3 V | DisplayPort RX analog power |
| B4, B5 | VDD12_RX | 1.2 V | DisplayPort RX analog power |
| C5 | VDD33_AUX | 3.3 V | DisplayPort AUX power |
| B7 | VDD12_PLL | 1.2 V | PLL analog power |
| F4 | VDD12_OSC | 1.2 V | Oscillator circuit power |
| G2, G4 | VDD33_TX | 3.3 V | HDMI TX analog power |
| G5, G7 | VDD12_TX | 1.2 V | HDMI TX analog power |
| D6, F5 | VDD12_DIG | 1.2 V | Core and 1.2V IO power |
| D3, E3 | VDD33_IO | 3.3 V | 3.3V IO power |
| B3, B6, D4, D5, E4, E5, G3, G6, D8 | GND | GND | Power return for all supplies |

8.2. Bootstrap configuration

DC levels on the bootstrap pins shown below are latched during the de-asserting edge of power-on reset (EXT_RESETN goes HIGH). The levels specified below must be adhered to for the normal function of the device.

Table 9. Bootstrap configuration

| Bootstrap signal name | Internal PU/PD | Assignment | Function |
|-----------------------|----------------|---------------|---|
| Bootstrap '0' | PULLUP | UART_TX (D7) | RESERVED. Leave as NC. |
| Bootstrap '1' | PULLUP | SPI_WPN (E2) | RESERVED. Leave as NC. |
| Bootstrap '2' | PULLDN | SPI_CLK (D2) | RESERVED. Leave as NC. |
| Bootstrap '3' | PULLDN | SPI_DO (D1) | RESERVED. Leave as NC. |
| Bootstrap '4' | PULLUP | SPI_CSN (C1) | RESERVED. Leave as NC. |
| Bootstrap '5' | PULLDN | GPIO1_33 (C3) | Can be used for customized application configuration. |
| Bootstrap '6' | PULLDN | GPIO2_33 (F3) | Can be used for customized application configuration. |

Note: When the pin corresponding to a specific bootstrap is left NC, the pin takes the value of the assigned by the internal PULLUP (Level 1) or PULLDN (Level 0). The internal resistor used is around 50 k Ω. To select a non-default value on a bootstrap, an external PULLUP or PULLDN resistor tied to the opposite direction that overcomes the internal PULLUP or PULLDN needs to be used.

8.3. EXT_RESETN connection

The EXT_RESETN pin must be pulled up to 3.3 V via a 2.2 Kohm +/- 10% resistor as shown below. The chip also supports an active low, external reset pulse to EXT_RESETN allowing a system host controller to reset the system. The recommended way to drive EXT_RESETN is through an open-drain output. Alternately, if an open-drain output is not available, the series resistor shown in the figure below is required.

Figure 8. EXT_RESETN Connection to MCDP2900

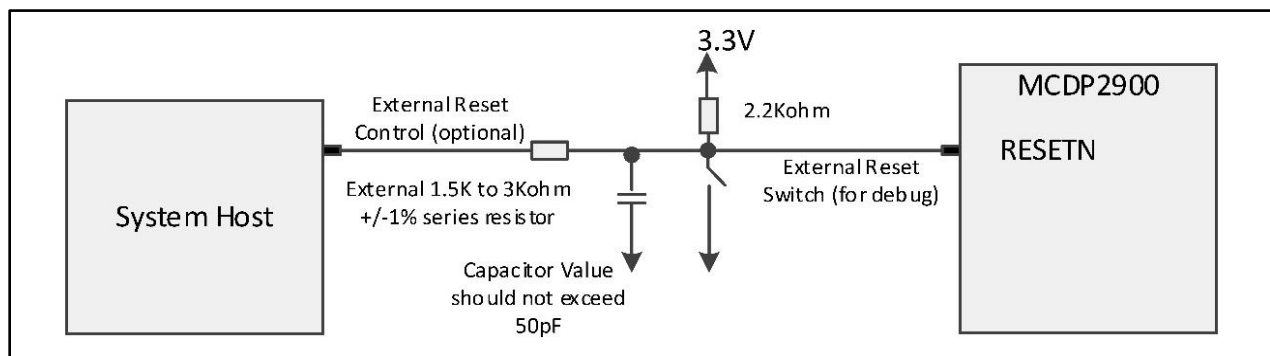

9. Package

Package type: LFBGA (7x7x1.4 mm, 64, F8x8, Pitch 0.8, Ball 0.4), Halogen free, RoHS compliant, ECOPACK2 certified.

9.1. Package drawing

Figure 9. MCDP2900 package drawing

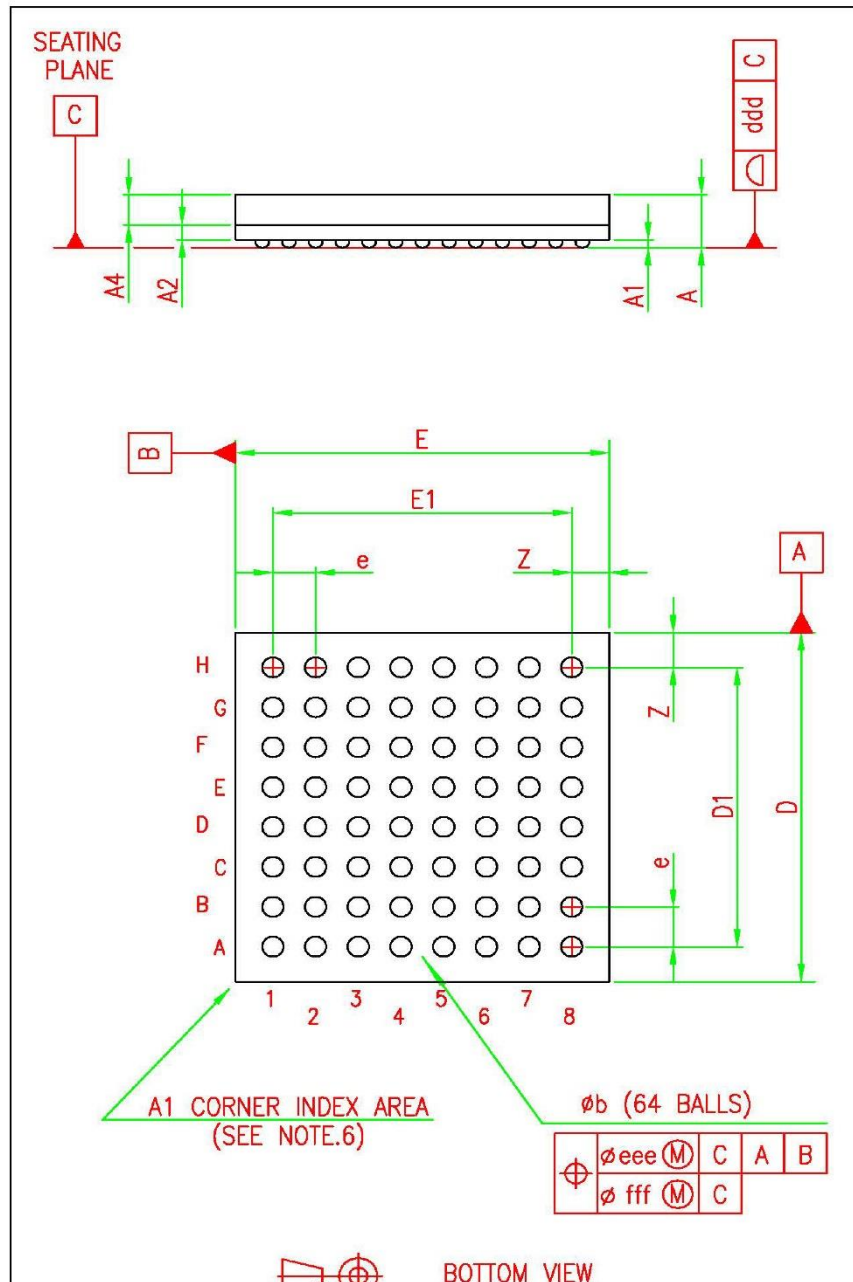

9.2. LFBGA 7 x 7 dimensions

Table 10. MCDP2900 package dimensions

| Ref | Databook (mm) | | | Drawing (mm) | | | Notes |
|-----|---------------|------|------|--------------|-------|-------|-------|
| | Min | Typ | Max | Min | Typ | Max | |
| A | | | 1.4 | 1.099 | 1.165 | 1.231 | (1) |
| A1 | 0.25 | | | 0.25 | 0.30 | 0.35 | |
| A2 | | 0.29 | | 0.24 | 0.28 | 0.32 | |
| A4 | | | 0.60 | 0.57 | 0.585 | 0.60 | |
| b | 0.35 | 0.40 | 0.45 | 0.35 | 0.40 | 0.45 | (2) |
| D | 6.95 | 7.00 | 7.05 | 6.95 | 7.00 | 7.05 | |
| D1 | | 5.60 | | | 5.60 | | |
| E | 6.95 | 7.00 | 7.05 | 6.95 | 7.00 | 7.05 | |
| E1 | | 5.60 | | | 5.60 | | |
| e | | 0.80 | | | 0.80 | | |
| Z | | 0.70 | | | 0.70 | | |
| ddd | | | 0.08 | | | 0.08 | |
| eee | | | 0.09 | | | 0.09 | (4) |
| fff | | | 0.05 | | | 0.05 | (5) |

NOTES:

- (1) - LFBGA stands for **L**ow profile **F**ine Pitch **B**all **G**rid **A**rray.
 - Thin profile: 1.00mm < A ≤ 1.20mm / Fine pitch: e < 1.00mm pitch.
 - The total profile height (Dim A) is measured from the seating plane to the top of the component
 - The maximum total package height is calculated by the following methodology:
 $A \text{ Max} = A1 \text{ Typ} + A2 \text{ Typ} + A4 \text{ Typ} + \sqrt{A1^2 + A2^2 + A4^2}$ tolerance values)
- (2) – The typical ball diameter before mounting is 0.40mm.
- (3) – LFBGA with 0.40mm pitch is not yet registered into JEDEC Publications.
- (4) - The tolerance of position that controls the location of the pattern of balls with respect to datums A and B.
 For each ball there is a cylindrical tolerance zone eee perpendicular to datum C and located on true position with respect to datums A and B as defined by e. The axis perpendicular to datum C of each ball must lie within this tolerance zone.
- (5) - The tolerance of position that controls the location of the balls within the matrix with respect to each other.
 For each ball there is a cylindrical tolerance zone fff perpendicular to datum C and located on true position as defined by e. The axis perpendicular to datum C of each ball must lie within this tolerance zone.
 Each tolerance zone fff in the array is contained entirely in the respective zone eee above
 The axis of each ball must lie simultaneously in both tolerance zones.
- (6) - The terminal A1 corner must be identified on the top surface by using a corner chamfer, ink or metallized markings, or other feature of package body or integral heatslug.
 - A distinguishing feature is allowable on the bottom surface of the package to identify the terminal A1 corner. Exact shape of each corner is optional.

9.3. Marking field template and descriptors

The MCDP2900 marking template is shown below:

Figure 10. Marking template

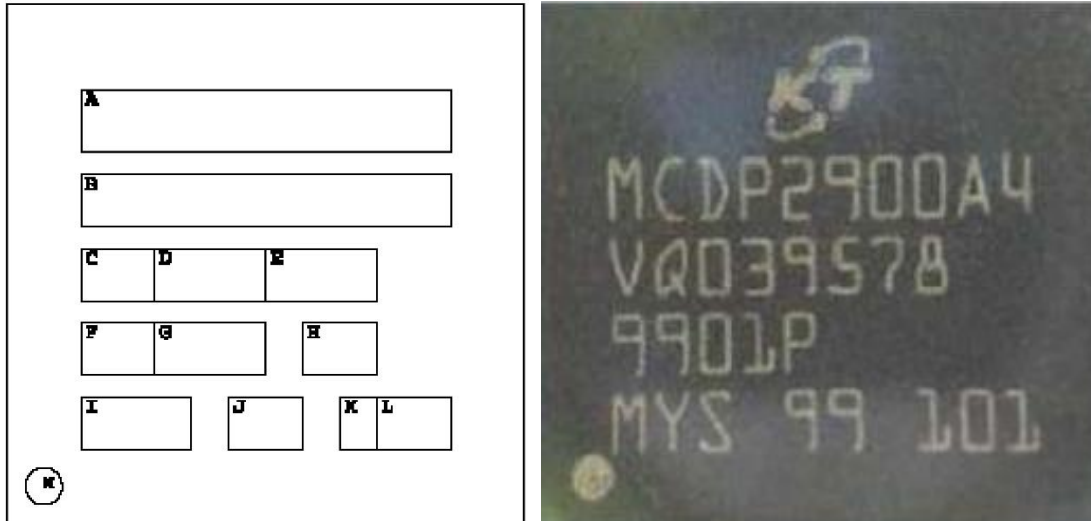

Field descriptors are shown below.

Table 11. Field descriptors

| Field | Description | Marking |
|-------|------------------------------------|---------------|
| A | Standard logo | Logo |
| B | Product code | MCDP2900A4 |
| C | 2-character diffusion plant code | VQ |
| D | 3-digit wafer start date | “YWW” |
| E | 3-character FE sequence code | “ABC” |
| F | 2-character assembly plant code | 99 |
| G | 3-character BE sequence code | “XYZ” |
| H | Optional marking | FX or <blank> |
| I | 3-character country of origin code | MYS |
| J | 2-character test plant code | 8U |
| K | 1-digit assembly year | “Y” |
| L | 2-digit assembly week | “WW” |
| M | Ball A1 identifier | a DOT |

9.4. Classification reflow profile

Please refer to the DisplayPort Application Note: Classification reflow profile for SMD devices (C0353-APN-06) for reflow diagram and details.

10. Electrical specifications

10.1. Absolute maximum ratings

Applied conditions greater than those listed under “Absolute maximum ratings”, may cause permanent damage to the device. The device should never exceed absolute maximum conditions since it may affect device reliability.

Table 12. Absolute maximum ratings

| Parameter | Symbol | Min | Typ | Max | Units |
|---|----------------------|------|-----|---------|-------|
| 3.3 V supply voltages ^(1,2) | V _{VDD_3.3} | -0.3 | 3.3 | 3.96 | V |
| 1.2 V supply voltages ^(1,2) | V _{VDD_1.2} | -0.3 | 1.2 | 1.44 | V |
| Input voltage tolerance for 3.3 V, 5 V tolerant I/O pins | V _{IN5tol} | -0.3 | | 5.5 | V |
| Input voltage tolerance for 3.3 V I/O pins | V _{IN3V3} | -0.3 | | 3.75 | V |
| ESD – Human Body Model (HBM)[JESD22-A114 spec] For all pins | V _{ESD} | - | - | +/- 2.0 | kV |
| ESD – Human Body Model (HBM) [IEC61000-4 spec] For DP and HDMI connector-facing pins | V _{ESD} | - | - | +/- 6.5 | kV |
| ESD – Charged Device Model (CDM) [JESD22-C101 spec] | V _{ESD} | - | - | +/- 500 | V |
| Latch-up [JESD78 spec] | I _{LA} | - | - | +/- 100 | mA |
| Ambient operating temperature | T _A | 0 | - | 70 | °C |
| Storage temperature | T _{STG} | -40 | - | 150 | °C |
| Operating junction temperature | T _J | 0 | 75 | 125 | °C |
| Thermal resistance (Junction to Ambient) ⁽³⁾ | θ _{JA} | - | - | 37.6 | °C/W |
| Thermal resistance (Junction to Case) ⁽³⁾ | θ _{JC} | - | - | 18.8 | °C/W |
| Peak IR reflow soldering temperature | T _{SOL} | - | - | 260 | °C |

Note 1: All voltages are measured with respect to GND.

Note 2: Absolute maximum voltage ranges are for transient voltage excursions.

Note 3: These are simulated results under the following conditions – Four layer JEDEC PCB, no heat spreader, Air flow = 0 m/s.

10.2. Power connections

Figure 11. Recommended Power supply connections for MCDP2900

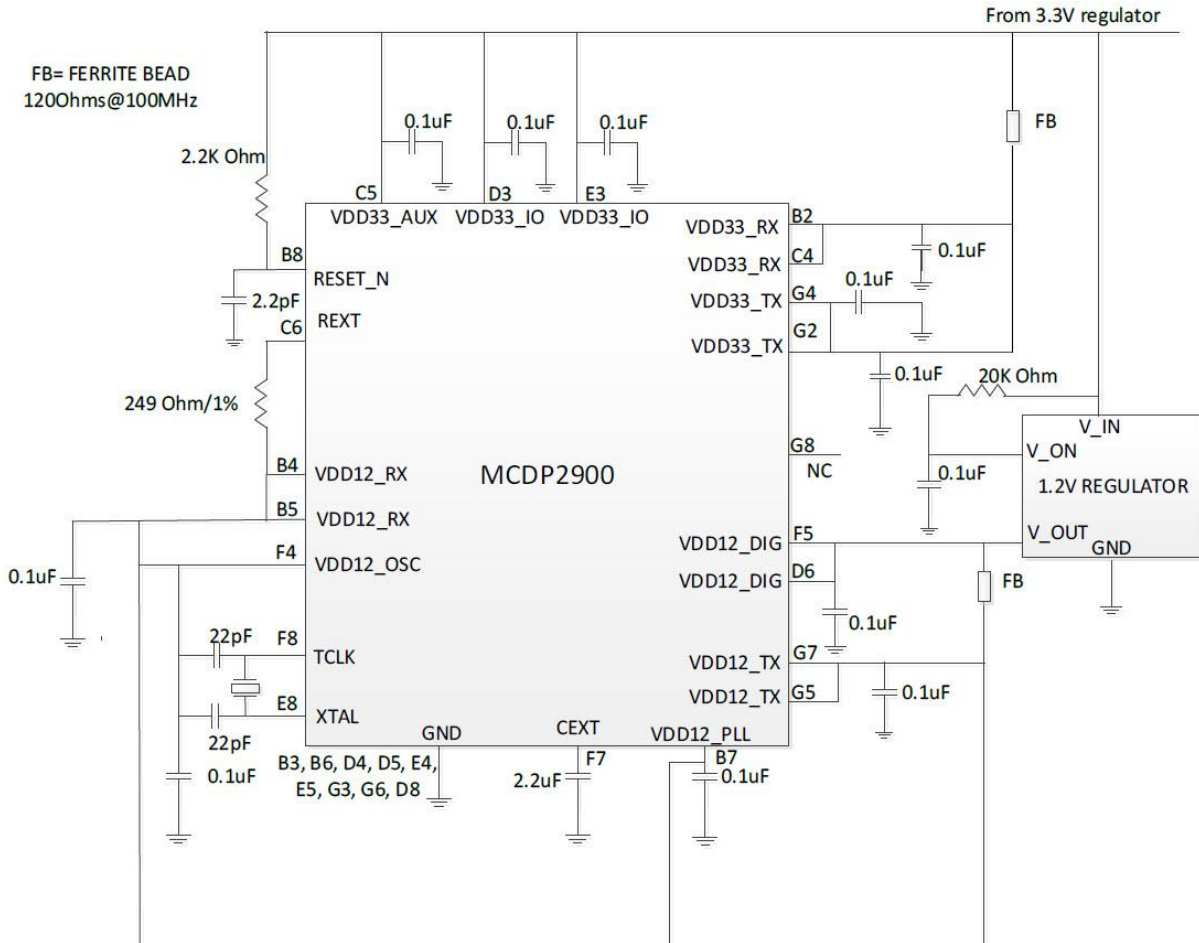

10.3. DC characteristics

Table 13. DC characteristics

| Parameter | Symbol | Min | Typ | Max | Units |
|---|----------------------|------|-----------|-----------|-------|
| 3.3 V supply voltages (analog and digital) | V _{VDD_3.3} | 3.14 | 3.3 | 3.47 | V |
| 1.2 V supply voltages (analog and digital) | V _{VDD_1.2} | 1.14 | 1.2 | 1.26 | V |
| Power | | | | | |
| Protocol converter Mode Measurement condition: Nominal corner, 25°C, Nominal power supply 4k x 2k / 60 Hz 4L HBR2-to-HDMI test pattern: ON-OFF | | | 482 | 570 | mW |
| 4k x 2k / 30 Hz 4L HBR2-to-HDMI test pattern: ON-OFF | | | 413 | 480 | mW |
| 1920 x 1080 / 60 Hz 4L HBR2-to-HDMI test pattern: ON-OFF | | | 380 | 440 | mW |
| Sleep State | | | 11 | | mW |
| Supply Current | | | | | |
| Measurement conditions: Nominal corner, 25°C, Nominal power supply 4k x 2k @60 MHz 4L HBR to HDMI VDD (analog and digital) 3.3V VDD (analog and digital) 1.2V | | | 25 332 | 27 390 | mA |

Note: Ripple amplitude for power supplies should be 30 mV or lower with max ripple freq up to 30 MHz.

Table 14. IO DC characteristics

| Parameter | Symbol | Min | Typ | Max | Unit |
|---|------------|------|-----|----------|----------|
| Inputs 3.3 V IO signals, 5 V tolerant open drain type | | | | | |
| High voltage | V_{IH} | 2.0 | | 5.5 | V |
| Low voltage | V_{IL} | -0.3 | | 0.8 | V |
| Input Hysteresis voltage | V_{HYST} | 300 | | | mV |
| High current ($V_{IN} = 3.3$ V) | I_{IH} | | | +/- 10 | μ A |
| Low current ($V_{IN} = 0.8$ V) | I_{IL} | | | +/- 10 | μ A |
| Input capacitance | C_{IN} | | 5 | | pF |
| Outputs 3.3 V IO signals, 5 V tolerant open drain type | | | | | |
| Low Current ($V_{OL} = 0.2$ V) | I_{OL} | 4 | | | mA |
| Tri-state leakage current | I_{OZ} | | | 10 | μ A |
| Inputs 3.3 V IO signals, 3.3 V tolerant, TRISTATE | | | | | |
| High voltage | V_{IH} | 2.0 | | | V |
| Low voltage | V_{IL} | | | 0.8 | V |
| Input Hysteresis voltage | V_{HYST} | 300 | | | mV |
| High current ($V_{IN} = 3.3$ V) | I_{IH} | | | ± 10 | μ A |
| Low current ($V_{IN} = 0.8$ V) | I_{IL} | | | ± 10 | μ A |
| Input capacitance | C_{IN} | | 1.0 | | pF |
| Outputs 3.3 V IO signals, 3.3 V tolerant, TRISTATE | | | | | |
| Output Impedance, $V_{OL}=0.3$ V | R_{out} | | 50 | | Ω |
| Tri-state leakage current | I_{OZ} | | | ± 10 | mA |

10.4. AC characteristics

Table 15. Maximum speed of operation

| Clock domain | Max speed of operation |
|--------------------------------------|------------------------|
| Reference Input Clock (TCLK) | 27 MHz |
| Reference Internal Clock (RCLK) | 324 MHz |
| On-Chip Microcontroller Clock (OCLK) | 150 MHz |

| Clock domain | Max speed of operation |
|---------------------------------|------------------------|
| 2-Wire Serial Slave (SLAVE_SCL) | 400 kHz |
| DDC Master (MSTRx_SCL) | 400 kHz |
| SPI Clock | 50 MHz |

10.4.1. DisplayPort receiver

Table 15. DisplayPort receiver characteristics

| Parameter | Symbol | Min | Typ | Max | Units | Comments |
|--|--------------------------|------|---------|-------|-------|--|
| Receiver operating range | | | | | | |
| Differential Input Voltage Range | $V_{RX_DIF_PP_RANGE}$ | | 0.04~1 | | V | |
| RX Termination Control Range | $R_{RX_TERM_RANGE}$ | | 80 ~120 | | ohm | |
| DisplayPort receiver system parameters | | | | | | |
| HBR2 unit interval (5.4Gbps) | UI_{HBR2} | | 185 | | ps | |
| HBR unit interval (2.7Gbps) | UI_{HBR} | | 370 | | ps | |
| RBR unit interval (1.62Gbps) | UI_{RBR} | | 617 | | ps | |
| Link clock down spreading | | 0 | | 0.5 | % | Modulation frequency range Of 30 kHz to 33 kHz |
| DisplayPort receiver TP3 parameters | | | | | | |
| Receiver Eye TP3 RBR | $T_{RBR_EYE_TP3}$ | 0.25 | | | UI | @ 40mV V_{diff_pp} |
| Receiver Eye TP3_EQ HBR | $T_{HBR_EYE_TP3EQ}$ | 0.4 | | | UI | @ 135mV V_{diff_pp} |
| Receiver Eye TP3_EQ HBR2 | $T_{HBR2_EYE_TP3EQ}$ | 0.3 | | | UI | @ 70mV V_{diff_pp} |
| Lane intra-pair skew tolerance | $T_{SKEW_INTRA_RBR}$ | | | 260 | ps | Skew contribution from the cable in addition to the stressed EYE at TP3. |
| | $T_{SKEW_INTRA_HBR}$ | | | 60 | ps | |
| | $T_{SKEW_INTRA_HBR2}$ | | | 50 | ps | |
| Target bit error rate 10^{-9} | | | | | | |
| Non-ISI at 1.62 Gbps | $T_{RX_Non-ISI_RBR}$ | | | 0.180 | UI | 1.62Gbps signal @ TP3 |
| TJ at 1.62 Gbps | $T_{RX_TJ_RBR}$ | | | 0.750 | UI | 1.62Gbps signal @ TP3 |
| Non-ISI at 2.7 Gbps | $T_{RX_Non-ISI_HBR}$ | | | 0.330 | UI | 2.7Gbps signal @ TP3_EQ |
| TJ at 2.7 Gbps | $T_{RX_TJ_HBR}$ | | | 0.491 | UI | 2.7 Gbps signal @ TP3_EQ |
| DJ at 5.4 Gbps | $T_{RX_DJ_HBR2}$ | | | 0.49 | UI | 5.4 Gbps signal @ TP3_EQ |
| TJ at 5.4 Gbps | $T_{RX_TJ_HBR2}$ | | | 0.62 | UI | 5.4 Gbps signal @ TP3_EQ |
| AUX parameters | | | | | | |

| Parameter | Symbol | Min | Typ | Max | Units | Comments |
|----------------------------------|---------------------------|-----|--------|-----|-------|----------------------------|
| Differential Input Voltage Range | $V_{AUX_RX_DIF_RANGE}$ | | 0.14~1 | | V | |
| RX Termination Control Range | $R_{AUX_TERM_RANGE}$ | | 40~60 | | ohms | |
| AUX TX peak-peak Range | $V_{AUX_TX_DIF_PP}$ | | 0~1 | | V | 7.8125mV/step in 128 steps |

10.4.2. HDMI transmitter I/O specifications

Table 16. HDMI transmitter DC specifications

| Parameters | Symbol | Min | Typ | Max | Unit | Comments |
|---|---------------------|------|-----|------|------|----------|
| Differential output: single ended swing amplitude | V_{TX_PP} | 0.4 | 0.5 | 0.6 | V | |
| Differential output: Differential swing amplitude | $V_{TX_DIF_PP}$ | 0.8 | 1 | 1.2 | V | |
| Differential high-level output | $V_{TX_DIF_HIGH}$ | 3.12 | 3.3 | 3.49 | V | |
| Differential low-level output | $V_{TX_DIF_LOW}$ | 3.12 | | 3.49 | V | |

Table 17. HDMI transmitter AC characteristics

| Parameters | Symbol | Min | Typ | Max | Unit | Comments |
|--|------------------------|-----|-----|------|------|--|
| TMDS Character Clock | $f_{TX_CHR_CLK}$ | 25 | | 600 | MHz | Programmable |
| Differential Output Voltage | $V_{TX_DIF_PP}$ | 0 | | 1200 | mV | In 128 steps |
| TX Edge Rate | t_{TX_ER} | 75 | | 145 | pS | 1V $V_{TX_DIF_PP}$ and Preemphasis at 0dB in 8 steps |
| TX Pre-Emphasis Level | A_{PREMPH} | 0 | | 6 | dB | 1V $V_{TX_DIF_PP}$ in 16 steps |
| TX Termination Control Range | $R_{TX_TERM_RANGE}$ | 100 | | 600 | ohms | Programmable Termination |
| TX Jitter <1.65Gbps for Pattern D10.2 | $T_{TX_J_D102_LF}$ | | | 60 | pS | |
| TX Jitter <1.65Gbps for Pattern PRBS7 | $T_{TX_J_PRBS7_LF}$ | | | 70 | pS | |
| TX Jitter >1.65Gbps, < 3.4Gbps for Pattern D10.2 | $T_{TX_J_D102_MF}$ | | | 35 | pS | |
| TX Jitter >1.65Gbps, < 3.4Gbps for Pattern PRBS7 | $T_{TX_J_PRBS7_MF}$ | | | 45 | pS | |
| TX Jitter >3.4Gbps for Pattern D10.2 | $T_{TX_J_D102_HF}$ | | | 30 | pS | |
| TX Jitter >3.4Gbps for Pattern PRBS7 | $T_{TX_J_PRBS7_HF}$ | | | 35 | pS | |

10.4.3. I2C interface timing

Table 18. I2C interface timing

| Symbol | Parameter | Conditions | Min | Typ | Max | Unit |
|---------------------|--------------------------------------|---|--------------------|-----|--------------------|------|
| f _{SCL} | SCL clock rate | Fast mode | 0 | - | 400 | kHz |
| t _{HD;STA} | Hold time START | After this period, the 1 st clock starts | 1.2 | - | - | μs |
| t _{LOW} | Low period of clock | SCL | 1.3 | - | - | μs |
| t _{HIGH} | High period of clock | SCL | 1.2 | - | - | μs |
| T _{SU;STA} | Set up time for a repeated START | | 1.2 | - | - | μs |
| t _{HD;DAT} | Data hold time | For master | 0.7 | - | 0.9 ⁽¹⁾ | μs |
| t _{SU;DAT} | Data setup time | | 380 | - | - | ns |
| T _{BUF} | Bus free time between STOP and START | | 1.3 | - | - | μs |
| C _b | Capacitance load for each bus line | | - | 100 | 400 | pF |
| t _r | Rise time | | 220 | - | 300 | ns |
| t _f | Fall time | | 60 | - | 300 | ns |
| V _{nh} | Noise margin at high level | | 0.25V _D | - | - | V |
| V _{nl} | Noise margin at low level | | 0.2V _{DD} | - | - | |

Note 1: The maximum t_{HD;DAT} only has to be met if the device does not stretch the low period t_{LOW} of the SCL signal. In the diagram below, S = start, P = stop, Sr = Repeated start, and SP= Repeated stop conditions.

Figure 12. I2C timing

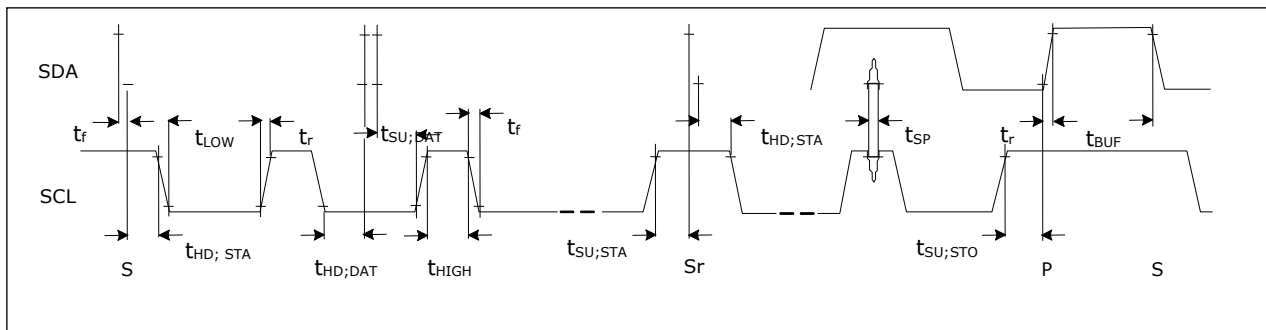

10.4.4. SPI interface timing

The table below specifies the typical SPI_CLK output frequency and the minimum requirements of the interface between the SPI NOR Flash device and the MCDP2900 SPI interface.

Table 19. SPI interface timing

| Symbol | Parameter | Min | Typ | Max | Units |
|------------------------|---|-----|-----|-----|-------|
| F _{CLK} | SPI_CLK output clock frequency | | 50 | | MHz |
| T _{SCKH} | Serial clock high time | | 20 | | ns |
| T _{SCKL} | Serial clock low time | | 20 | | ns |
| T _{R_SPI_CLK} | SPI_CLK rise time @10mA drive 10pF load | | | 2.8 | ns |
| T _{F_SPI_CLK} | SPI_CLK fall time @10mA drive 10pF load | | | 3.2 | ns |
| T _{CSN_SU} | CSN output setup time requirement | 7 | | | ns |
| T _{CSN_HLD} | CSN output hold time requirement | 7 | | | ns |
| T _{DO_PD} | Data Output propagation delay | | | 6 | ns |
| T _{DI_SU} | Data Input setup time | 3 | | | ns |
| T _{DI_HLD} | Data Input hold time | 5 | | | ns |

11. Ordering information

Table 20. Order codes

| Part Number | Operating Temperature | Package |
|--------------------|------------------------------|--------------------------------------|
| MCDP2900A4 | 0°C to +70°C | 64 LFBGA (7x7x1.4 mm) in Tray |
| MCDP2900A4T | 0°C to +70°C | 64 LFBGA (7x7x1.4 mm) in Tape & Reel |

Mouser Electronics

Authorized Distributor

Click to View Pricing, Inventory, Delivery & Lifecycle Information:

[Kinetic Technologies:](#)

[MCDP2900A4T](#)