

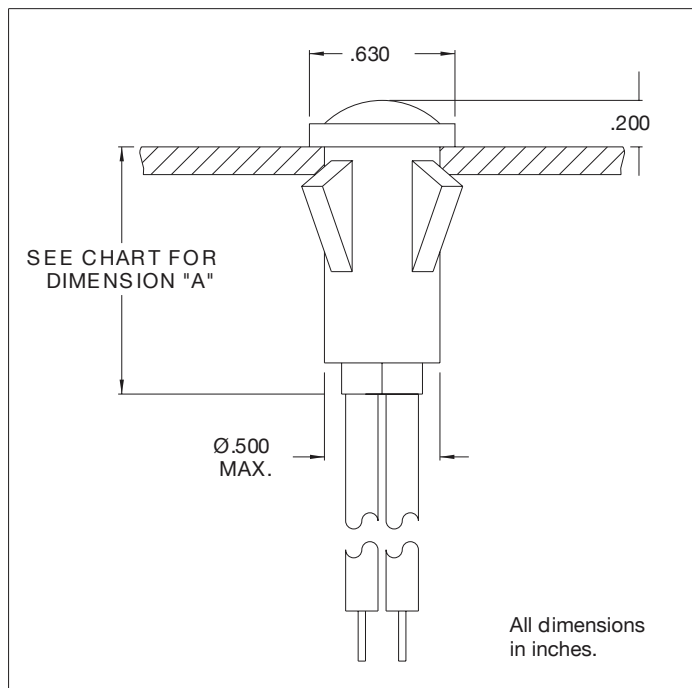

1030D, 1031D, 1032D , 1033D and 1090D Series Non-Relampable Neon-Incandescent Indicator Lights



Mounting: Will snap-fit into Ø.500/.505 hole in panels .020/.100 thick. Push-on speednut SN0461 also available.

Wire Leads: No. 22 AWG (105°C) 4.40/4.80 long, stripped .430/.570

Lens: Polycarbonate

Bezel: Polished stainless steel.

Housing: White Nylon

Wattage: (1032D5 - .5W)

LensColor	Neon		Incandescent	
	Model No. (105-125VAC)	Model No. (208-250VAC)	Model No. (12V)	Model No. (28V)
Red	1030D1	1031D1	1090D1-12V	1090D1-28V
Amber	1030D3	1031D3	1090D3-12V	1090D3-28V
White	1030D4	1031D4	-	1090D4-28V
Green	1032D5*	1033D5*	1090D5-12V	1090D5-28V
Lamp used	C2A + Resistor		#2162	#2187
Lead Color	Black	One Black/One Red	Yellow	Purple
"A"	1.130	1.130	.910	.910

* Incorporates G2B lamp and resistor.
Underwriters Laboratories (UL) File No. E20356

Compliance & Approvals



PART NUMBER	VOLTAGE	LENS COLOR	DIMENSION "A"	LAMP (DESCRIPTION)	WIRE LEADS	WIRE LEAD COLOR(S)	LEAD LENGTH	LEADSTRIP LENGTH
1030D1	105-125VAC	RED	1.13" (28.7mm)	LN2730(C2A+30K RESISTOR)	22 AWG PVC (105°C)	BLACK	4.4"/4.8(11.8mm/121.9mm)	0.43"/0.57"(10.9mm/14.5mm)
1030D3	105-125VAC	AMBER	1.13" (28.7mm)	LN2730(C2A+30K RESISTOR)	22 AWG PVC (105°C)	BLACK	4.4"/4.8(11.8mm/121.9mm)	0.43"/0.57"(10.9mm/14.5mm)
1030D4	105-125VAC	WHITE	1.13" (28.7mm)	LN2730(C2A+30K RESISTOR)	22 AWG PVC (105°C)	BLACK	4.4"/4.8(11.8mm/121.9mm)	0.43"/0.57"(10.9mm/14.5mm)
1032D5	105-125VAC	GREEN	1.13" (28.7mm)	LN5131(C2B+39K RESISTOR)	22 AWG PVC (105°C)	BLACK	4.4"/4.8(11.8mm/121.9mm)	0.43"/0.57"(10.9mm/14.5mm)
1031D1	208-250V	RED	1.13" (28.7mm)	LN2731(C2A+100K RESISTOR)	22 AWG PVC (105°C)	(1) BLACK/ (1) RED	4.4"/4.8(11.8mm/121.9mm)	0.43"/0.57"(10.9mm/14.5mm)
1031D1_7	208-250V	RED	1.13" (28.7mm)	LN2731(C2A+100K RESISTOR)	22 AWG PVC (105°C)	(1) BLACK/ (1) RED	7.0" (+ 1/4" / - 1/16")	0.43"/0.57"(10.9mm/14.5mm)
1031D3	208-250V	AMBER	1.13" (28.7mm)	LN2731(C2A+100K RESISTOR)	22 AWG PVC (105°C)	(1) BLACK/ (1) RED	4.4"/4.8(11.8mm/121.9mm)	0.43"/0.57"(10.9mm/14.5mm)
1031D4	208-250V	WHITE	1.13" (28.7mm)	LN2731(C2A+100K RESISTOR)	22 AWG PVC (105°C)	(1) BLACK/ (1) RED	4.4"/4.8(11.8mm/121.9mm)	0.43"/0.57"(10.9mm/14.5mm)
1033D5	208-250V	GREEN	1.13" (28.7mm)	LN15133(G2B+120K RESISTOR)	22 AWG PVC (105°C)	(1) BLACK/ (1) RED	4.4"/4.8(11.8mm/121.9mm)	0.43"/0.57"(10.9mm/14.5mm)
1090D1-6V	6V	RED	0.91"/(23.1mm)	2112(6.3V, 0.20A)	22 AWG PVC (105°C)	WHITE	4.4"/4.8(11.8mm/121.9mm)	0.43"/0.57"(10.9mm/14.5mm)
1090D1-12V	12V	RED	0.91"/(23.1mm)	2162(14.0V, 0.10A)	22 AWG PVC (105°C)	YELLOW	4.4"/4.8(11.8mm/121.9mm)	0.43"/0.57"(10.9mm/14.5mm)
1090D1-28V	28V	RED	0.91"/(23.1mm)	2187(28.0V, 0.04A)	22 AWG PVC (105°C)	PURPLE	4.4"/4.8(11.8mm/121.9mm)	0.43"/0.57"(10.9mm/14.5mm)
1090D3-6V	6V	AMBER	0.91"/(23.1mm)	2112(6.3V, 0.20A)	22 AWG PVC (105°C)	WHITE	4.4"/4.8(11.8mm/121.9mm)	0.43"/0.57"(10.9mm/14.5mm)
1090D3-12V	12V	AMBER	0.91"/(23.1mm)	2162(14.0V, 0.10A)	22 AWG PVC (105°C)	YELLOW	4.4"/4.8(11.8mm/121.9mm)	0.43"/0.57"(10.9mm/14.5mm)
1090D3-28V	28V	AMBER	0.91"/(23.1mm)	2187(28.0V, 0.04A)	22 AWG PVC (105°C)	PURPLE	4.4"/4.8(11.8mm/121.9mm)	0.43"/0.57"(10.9mm/14.5mm)
1090D4-6V	6V	WHITE	0.91"/(23.1mm)	2112(6.3V, 0.20A)	22 AWG PVC (105°C)	WHITE	4.4"/4.8(11.8mm/121.9mm)	0.43"/0.57"(10.9mm/14.5mm)
1090D4-12V	12V	WHITE	0.91"/(23.1mm)	2162(14.0V, 0.10A)	22 AWG PVC (105°C)	YELLOW	4.4"/4.8(11.8mm/121.9mm)	0.43"/0.57"(10.9mm/14.5mm)
1090D4-28V	28V	WHITE	0.91"/(23.1mm)	2187(28.0V, 0.04A)	22 AWG PVC (105°C)	PURPLE	4.4"/4.8(11.8mm/121.9mm)	0.43"/0.57"(10.9mm/14.5mm)
1090D5-6V	6V	GREEN	0.91"/(23.1mm)	2112(6.3V, 0.20A)	22 AWG PVC (105°C)	WHITE	4.4"/4.8(11.8mm/121.9mm)	0.43"/0.57"(10.9mm/14.5mm)
1090D5-12V	12V	GREEN	0.91"/(23.1mm)	2162(14.0V, 0.10A)	22 AWG PVC (105°C)	YELLOW	4.4"/4.8(11.8mm/121.9mm)	0.43"/0.57"(10.9mm/14.5mm)
1090D5-28V	28V	GREEN	0.91"/(23.1mm)	2187(28.0V, 0.04A)	22 AWG PVC (105°C)	PURPLE	4.4"/4.8(11.8mm/121.9mm)	0.43"/0.57"(10.9mm/14.5mm)