

# RJF

Ethernet connection system for harsh environment – Industrial Ethernet



RJF allows you to use an Ethernet Class D / Cat. 5e connection for 10 BaseT, 100 BaseTX or 1000 BaseT networks in harsh environments. With the patented RJStop® system you can use a standard RJ45 cordset in a **metallic** plug which will protect it from shocks, dust and fluids. **No hazardous on-field cabling and grounding!**

### Applications

- Robotics
- Industrial process control
- CNC machines
- Special machines
- Oil & Gas
- Motion control
- Data acquisition and transmission in harsh environment
- Tele-maintenance

### Data transmission

10 BaseT, 100 BaseTX and 1000 BaseT networks  
Cat 5e per TIA/EIA 568B and ClassD per ISO/IEC 11801

### Main characteristics

- Compliant with IEC 60603-7 variante 11
- **Bayonet coupling** ("Audible & Visual" coupling signal)
- **Robust metallic shells based on MIL-DTL-26482 H - Shell size 18**
- RJ45 cordset retention in the plug: 100 N in the axis
- Mating cycles: 500 min
- Sealed against fluids and dust (IP68)
- Shock, vibration and traction resistant
- No cabling operation in field and no tools required
- Mechanical coding / polarization (4 positions)
- Compatible with cable diameter from 6 mm [0.236 in] to 13 mm [0.512 in]  
For smaller diameters, please consult us.

### Environmental protection

- Sealing: IP68
- Salt spray: 48 h with nickel plating  
> 96 h with black coating  
< 500 h with olive drab cadmium
- Fire retardant/Low smoke: UL94 V0 and NF F 16 101 & 16 102
- Vibrations: 10-500Hz, 10g, 3 axes: no discontinuity >10 nano s
- Shocks: IK06 ► weight of 250 g drop from 40cm [15.75 in] onto connectors (mated pair)
- Humidity: 21 days, 43°C, 98% humidity
- Thermal shock: 5 cycles at -40°C / +100°C
- Temperature range: -40°C / +85°C
- Storage temperature:

### Part number code

	RJF	2	2	B	03 100BTX
<b>Shell type</b>					
<b>6:</b> plug, plastic gland					
<b>6M:</b> plug, metal gland					
<b>2:</b> square flange receptacle					
<b>2PE:</b> square flange receptacle, IP68 backshell, plastic gland					
<b>2PEM:</b> square flange receptacle, IP68 backshell, metal gland					
<b>7:</b> jam nut receptacle					
<b>7PE:</b> jam nut receptacle, IP68 backshell, plastic gland					
<b>7PEM:</b> jam nut receptacle, IP68 backshell, metal gland					
<i>Nota: also available a transversally sealed receptacle (unmated) ► see page 22</i>					
<b>Back terminations (for receptacles only)</b>					
<b>1:</b> female RJ45					
<b>1RA:</b> right angle female RJ45					
<b>2:</b> RJ45 cordset					
<b>Shell finishes</b>					
<b>B:</b> black Coating - ROHS compliant					
<b>N:</b> nickel (note: with this version, the inserts are metallized) - ROHS compliant					
<b>G:</b> olive drab cadmium (note: with this version, the inserts are metallized)					
<b>BZC:</b> aluminium shell - black zinc cobalt plating					
<b>ZC:</b> aluminium shell - green zinc cobalt plating - ROHS compliant					
<b>Cordset length (for receptacles with "2" back termination only) - Other lengths are available on demand</b>					
<b>03 100 BTX:</b> 0.3m [11.81 inches]					<b>00:</b> 8 tinned holes at the rear of the PCB to solder the cable
<b>05 100 BTX:</b> 0.5m [19.68 inches]					<b>OPEN:</b> open cable - with no plug at the end
<b>10 100 BTX:</b> 1m [39.37 inches]					
<b>15 100 BTX:</b> 1.5m [59.05 inches]					
<b>Remark: Cabling configuration</b> → 100 BTX = 568B (Ethernet specification)					

- Examples:
- Nickel plug: RJF 6 N
  - Black square flange receptacle, female RJ45 back termination: RJF 2 1 B
  - Olive drab cadmium jam nut receptacle, 1.5m [59.05"] 100 BTX cordset termination: RJF 7 2 G 15 100BTX
  - Black in line square flange receptacle, 30cm [11.81"] 100BTX cordset termination: RJF 2PE 2 B 03 100BTX
  - Nickel jam nut receptacle, solder termination: RJF 72 N 00

## Plug

- Shell type 6 with plastic or metal gland

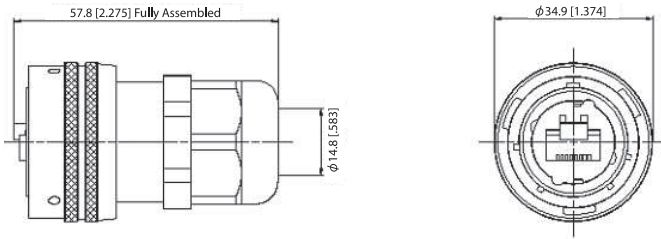

## Receptacles

- Square flange receptacle • 4 mounting holes: shell type 2

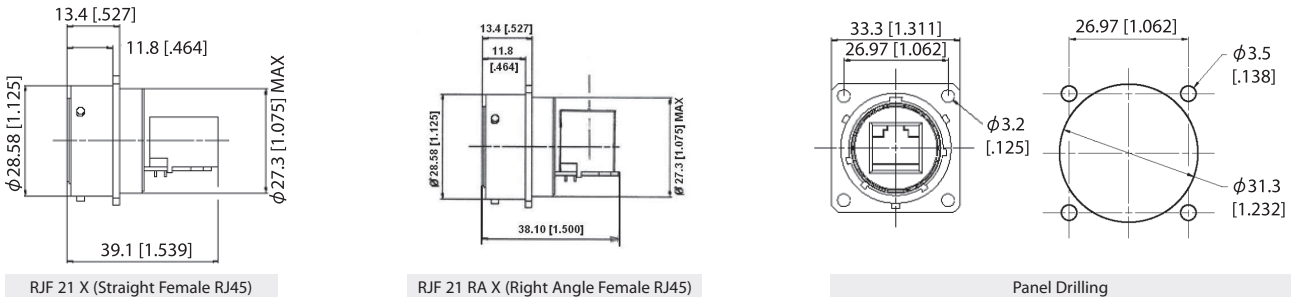

- Jam nut receptacle • Hexagonal nut mounting: shell type 7

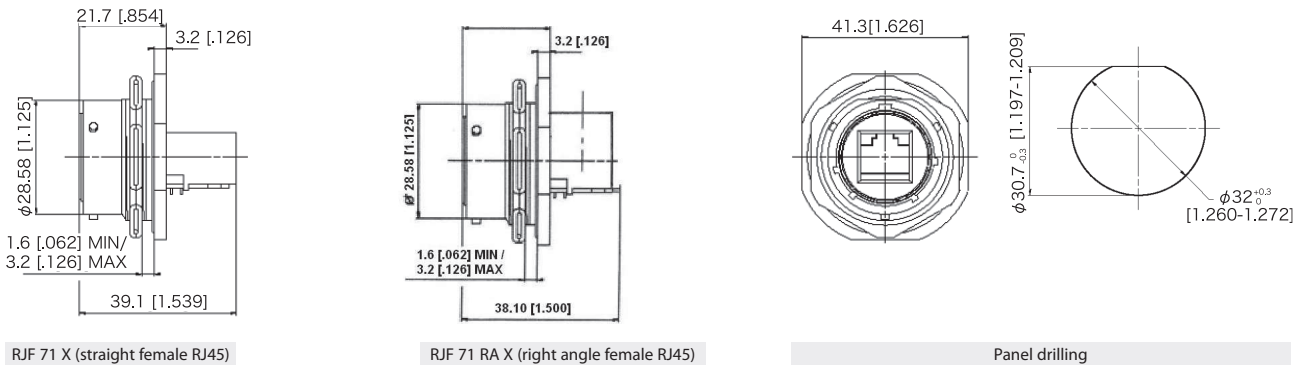

- Receptacles with IP68 backshell : shell type 2PE and 7PE with plastic or metal gland

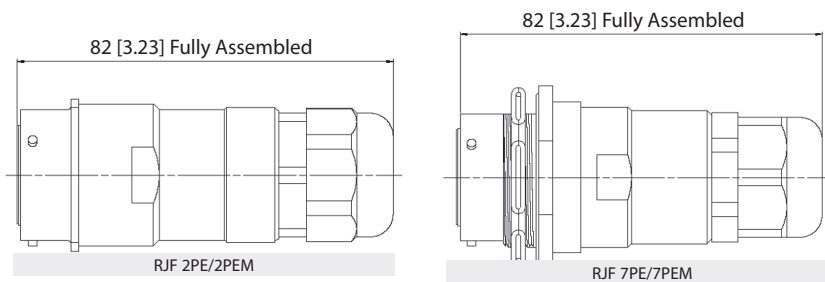

## Back terminations

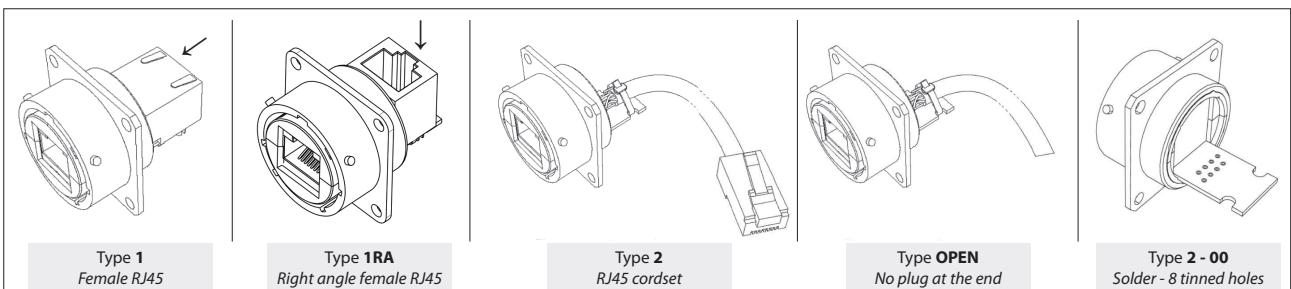

Universal: can be used with all standard RJ45 Cat.5e cordset brands.

**Assembly instructions of the RJ Stop**

1. Push down the RJ45 cordset latch, and fix it inside the insert
2. Press in and click the other part of the insert
3. Insert in the metallic housing

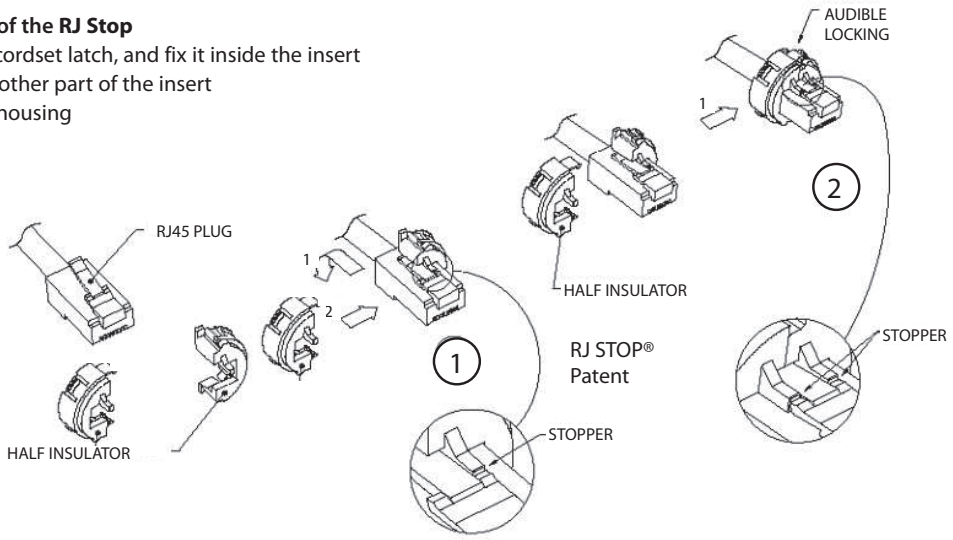

Easy and safe - No field cabling tools required for cabling

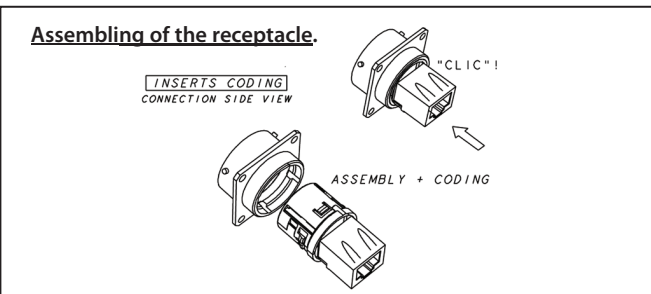
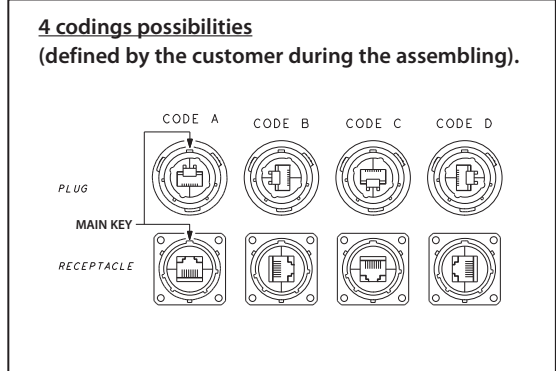
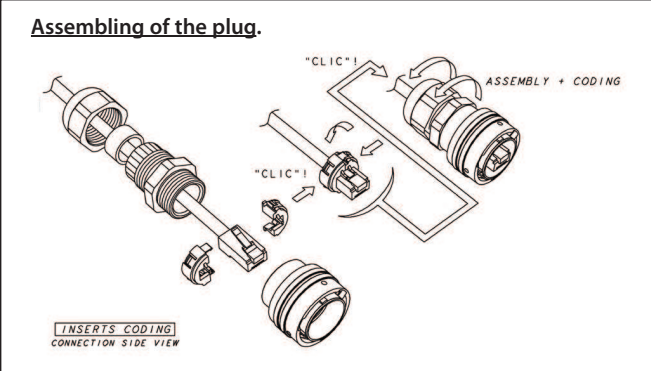

**IMPORTANT NOTE:** to remove the insert, use the  
 ■ Insert removal tool for receptacle and plug  
 P/N: RJF ODE



**Accessories**

■ **Metallic cap**

	RJFC	2	G
<b>Connector type</b>			
6: plug			
2: square Flange Receptacle			
7: jam Nut Receptacle			
<b>Shell material &amp; finish</b>			
B: black coating - ROHS compliant			
N: aluminium shell - nickel plating - ROHS compliant			
G: aluminium shell - olive drab cadmium plating			

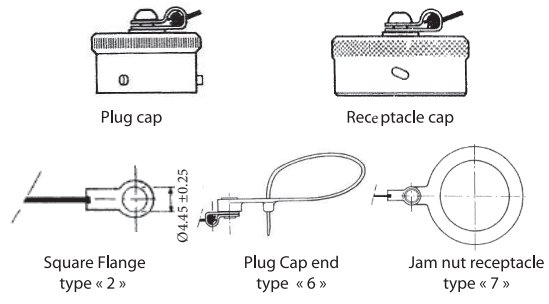

■ Panel gasket for square flange 2 »thickness - 0,6 mm  
 P/N: JE 18

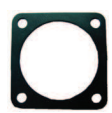

# RJF

Special receptacles: cable mount inline & PC tails

## Inline cable mount receptacles

Inline receptacles allow you to make cable extensions in the field by using them with rugged RJ Field series plugs.

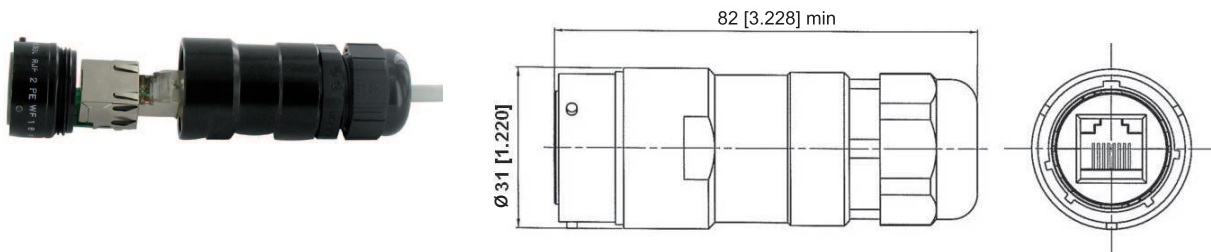

	Plating	Plastic gland	Metallic gland
<b>Part number</b>	Black coating - <i>ROHS compliant</i>	RJF2PEWF1B	RJF2PEMWF1B
	Nickel - <i>ROHS compliant</i>	RJF2PEWF1N	RJF2PEMWF1N
	Olive drab cadmium	RJF2PEWF1G	RJF2PEMWF1G

## PC tails receptacles

These receptacles can be soldered directly on your PCB. A compound insures a transversal sealing and good performance in high vibration environments. They can be connected with rugged RJField series plugs.

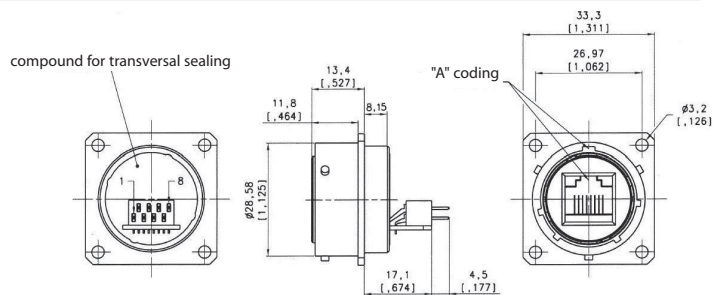

### PCB LAYOUT – SOLDER FACE VIEW

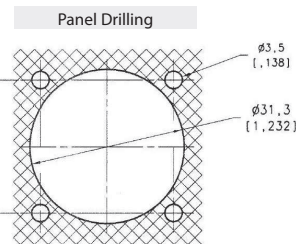
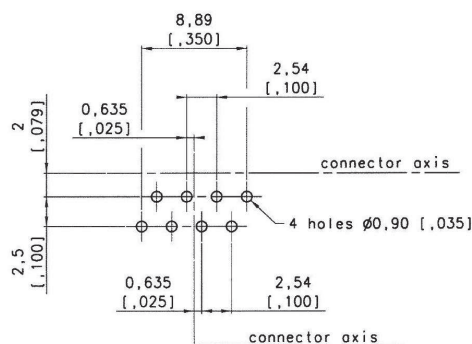

	Plating	Part number
<b>Part number</b>	Black coating - <i>ROHS compliant</i>	RJF 2S X 5B
	Nickel - <i>ROHS compliant</i>	RJF 2S X 5N
	Olive drab cadmium	RJF 2S X 5G

X to be replaced by the letter of the coding position you need (A, B, C, or D) ▶

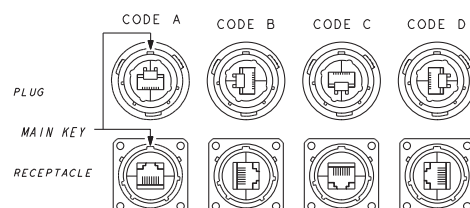



# RJF

## Receptacles & plugs with 360° EMI backshell

RJF series receptacles and plugs with EMI backshells provide a solution with 360° shielding; same protection than the one proposed by standard MIL-DTL-26482H connectors. With those solutions we recommend using our reinforced and double shielded Cat5E, Cat6, or Cat6A cable ► see pages 41-42-43.

### Square flange receptacle - Straight backshell

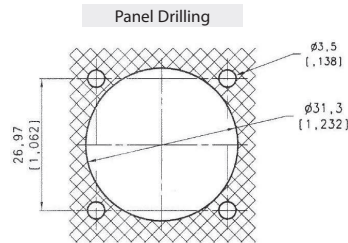
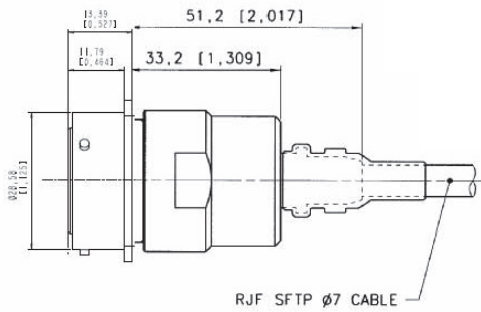

Part number	Plating	Part number
	Nickel - ROHS compliant	Kit30439NI
	Olive drab cadmium	Kit30439

Kit30439 & Kit30439NI include:

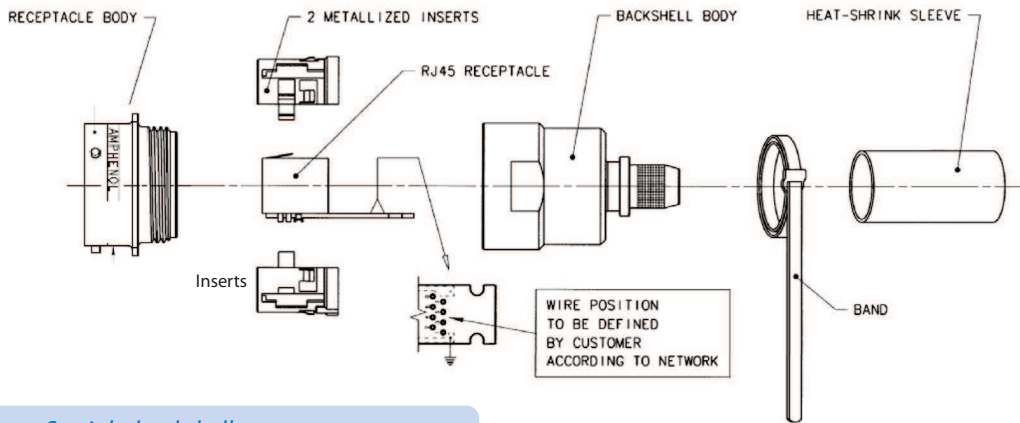

### Plug - Straight backshell

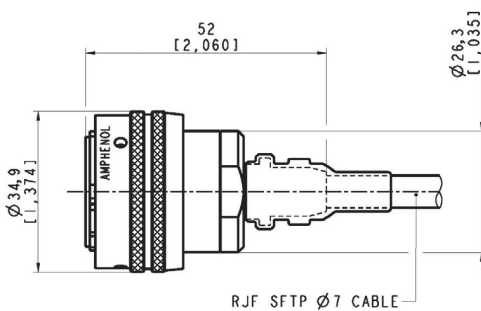

Part number	Plating	Part number
	Nickel - ROHS compliant	Kit30394NI
	Olive drab cadmium	Kit30394

Kit30394 & Kit30394NI include:



# RJF

Environmentally sealed receptacles, transversally sealed receptacles



In some applications, a transversal sealing for the receptacle is a « must ». This will prevent fluids and dust from going through the receptacle when plug or cap are not mated to the receptacle.

The sealed solution (version "S") has a compound at the rear of the receptacle as shown on the examples below. This feature is available both in RJF and RJF TV shells (please consult the relevant data sheet for product details and accessories). In addition, the Sealed RJF TV has been successfully tested in very high vibration corresponding to airplane applications.

### Applications

- Outdoor equipment
- Airplanes equipment
- Tactical radios
- Shelters
- Rugged computers
- Data acquisition and transmission in harsh environments

### Data transmission

10 BaseT, 100 BaseTX and 1000 BaseT networks  
Cat 5e per TIA/EIA 568B and ClassD per ISO/IEC 11801

### Main characteristics

- Same as the RJF and RJF TV series.
- A complete IP68 sealing of the receptacle (even with no plug or no protective cap mated) is added.
- Outside dimensions are the same as the standard RJF and RJF TV series.
- Vibrations: the compounded versions of the RJF TV have been tested in vibration following the NAS 1599 Aeronautic specification (Ambient temperature):  
5 - 3000 Hz, 20g, 2,5 mm [.1 inch] double amplitude, 3 axes, 12 hours  
Note: this specification exceeds MIL-C-26500 requirements.

### IMPORTANT NOTE

Due to the compound, the coding of the connector must be done in the factory : use the codes A, B, C or D in the part number: **see below**.

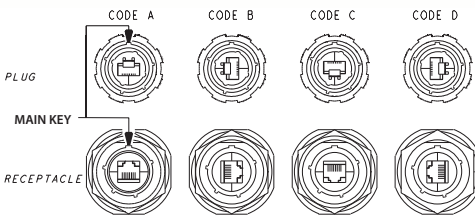

Example :  
RJFTV 2S A2 G 15 100BTX

### Part number code

Series	RJF	7S	A	2	G	03 100BTX
<b>RJF:</b> MIL-DTL-26482 H bayonet						
<b>Shell type</b>						
<b>2S:</b> sealed square flange receptacle						
<b>7S:</b> sealed jam nut receptacle						
<b>Coding</b>						
<b>A,B,C,D</b>						
<b>Back terminations</b> (for receptacles only)						
<b>1:</b> female RJ45						
<b>1RA:</b> right angle female RJ45						
<b>2:</b> RJ45 Cordset						
<b>Shell material &amp; finish</b>						
<b>B:</b> aluminium shell - black coating - ROHS compliant						
<b>N:</b> aluminium shell - nickel plating - ROHS compliant						
<b>G:</b> aluminium shell - olive drab cadmium plating						
<b>Nota:</b> for nickel and olive drab cadmium plating, receptacle inserts are metallized.						
<b>Cordset length</b> (For Receptacles with "2" Back Termination only) - Other lengths are available on demand						
<b>03 100 BTX:</b> 0.3m [11.81 inches]						
<b>05 100 BTX:</b> 0.5m [19.68 inches]						
<b>10 100 BTX:</b> 1m [39.37 inches]						
<b>15 100 BTX:</b> 1.5m [59.05 inches]						
<b>OPEN:</b> open cable - with no plug at the end						
<b>Remark: cabling configuration:</b> 100 BTX = 568B (Ethernet specification)						

- Examples:
- bayonet, sealed jam nut receptacle, A coding, with female RJ45 back termination, olive drab cadmium plating: **RJF 7SA 1 G**
  - bayonet, sealed square flange receptacle, A coding, with female RJ45 back termination, black plating: **RJF 2SA 1 B**
  - bayonet, sealed jam nut receptacle, A coding, 1.5m [59.05"] 100 BTX cordset, olive drab cadmium plating: **RJF 7SA 2 G15 100BTX**

# RJF

## Hermetic receptacles



In some applications, a transversal hermiticity for the receptacle is a « must ». This will prevent gas from going through the receptacle when plug or cap are not mated to the receptacle. The hermetic solution (version "H") has a compound at the rear of the receptacle as shown on the examples below. This feature is available both in RJF and RJF TV shells (please consult the relevant data sheet for product details and accessories). Helium leakage is less than  $1.10^{-6}$  cm<sup>3</sup> per second [0.1 micron cubic ft per hour] at one bar [15 psi] pressure differential.

- Applications**
- Outdoor equipment
  - Airplanes equipment
  - Tactical radios
  - Shelters
  - Rugged computers
  - Data acquisition and transmission in harsh environments

**Data Transmission**  
 10 BaseT, 100 BaseTX and 1000 BaseT networks  
 Cat 5e per TIA/EIA 568B and ClassD per ISO/IEC 11801

- Main characteristics**
- Same as the RJF and RJF TV series.
  - A complete IP68 sealing of the receptacle (even with no plug or no protective cap mated) is added.
  - Outside dimensions are the same as the standard RJF and RJF TV series.
  - Vibrations: the compounded versions of the RJF TV have been tested in vibration following the NAS 1599 Aeronautic specification (Ambient temperature):  
 5 - 3000 Hz, 20g, 2,5 mm [.1 inch] double amplitude, 3 axes, 12 hours  
 Note: this specification exceeds MIL-C-26500 requirements.

**IMPORTANT NOTE**

Due to the compound, the coding of the connector must be done in the factory: use the codes A, B, C or D in the part number: **see below.**

PLUG

MAIN KEY

RECEPTACLE

CODE A

CODE B

CODE C

CODE D

**Example :**  
RJF TV 2H A2 N 15 100BTX

Series	RJF	7H	A	2	G	03 100BTX
<b>RJF:</b> MIL-DTL-26482 H bayonet						
<b>Shell type</b>						
<b>2H:</b> transversally sealed and hermetic square flange receptacle						
<b>7H:</b> transversally sealed and hermetic jam nut receptacle						
<b>Coding</b>						
<b>A,B,C,D</b>						
<b>Back terminations (for receptacles only)</b>						
<b>1:</b> female RJ45						
<b>1RA:</b> right angle female RJ45						
<b>2:</b> RJ45 Cordset						
<b>Shell material &amp; finish</b>						
<b>B:</b> aluminium shell - black coating - ROHS compliant						
<b>N:</b> aluminium shell - nickel plating - ROHS compliant						
<b>G:</b> aluminium shell - olive drab cadmium plating						
<b>Nota:</b> for nickel and olive drab cadmium plating, receptacle inserts are metallized.						
<b>Cordset length (for receptacles with "2" back termination only) - Other lengths are available on demand</b>						
<b>03 100 BTX:</b> 0.3m [11.81 inches]						
<b>05 100 BTX:</b> 0.5m [19.68 inches]						
<b>10 100 BTX:</b> 1m [39.37 inches]						
<b>15 100 BTX:</b> 1.5m [59.05 inches]						
<b>OPEN:</b> open cable - with no plug at the end						
<b>Remark: cabling configuration:</b> 100 BTX = 568B (Ethernet specification)						

**Examples:**

- bayonet, sealed jam nut receptacle, A coding, with female RJ45 Back termination, olive drab cadmium plating: **RJF 7HA 1 G**
- bayonet, sealed square flange receptacle, A coding, with female RJ45 back termination, black plating: **RJF 2HA 1 B**
- bayonet, sealed jam nut receptacle, A coding, 1.5m [59.05"] 100 BTX cordset, olive drab cadmium plating : **RJF 7HA 2 G15 100BTX**



# RJF

Special plug for big insulation wire up to 1.6 mm [0.062 in]



Rugged plug dedicated to cable with insulation wire from 1,1 to 1,6 mm [from 0.043 in to 0.062 in]

**Remark:**

- Solution compatible with any RJF receptacle
- For cables which are not compatible with standard RJ45 plug.

### Applications

- Robotics
- Industrial process control
- CNC machines
- Special machines
- Oil & Gas
- Motion control
- Data acquisition and transmission in harsh environment
- Tele-maintenance

### Main characteristics

- Bayonet coupling ("Audible & Visual" coupling signal)
- Robust metallic shells based on MIL-DTL-26482 H - Shell size 18
- RJ45 cordset retention in the plug: 100 N in the axis
- Mating cycles: 500 min
- Sealed against fluids and dust (IP68)
- Shock, vibration and traction resistant
- Mechanical coding / polarization (4 positions)
- Compatible with cable diameter from 6 mm [0.216 in] to 13 mm [0.512 in], for smaller diameters, please consult us

### Environmental protection

- Sealing: IP68
- Salt Spray: 48 h with nickel plating  
> 96 h with black coating  
> 500 h with oliv drab cadmium
- Fire retardant/Low smoke: UL94 V0 and NF F 16 101 & 16 102
- Vibrations: 10 – 500 Hz, 10 g, 3 axes: no discontinuity >10 nano s.
- Shocks: IK06 ► weight of 250 g drop from 40 cm [15.75 in] onto connectors (mated pair)
- Humidity: 21 days, 43°C, 98% humidity
- Thermal shock: 5 cycles at - 40°C / +100°C
- Temperature range: - 40°C / +85°C

### Data transmission

10 BaseT, 100 BaseTX and 1000 BaseT networks  
Cat 5e per TIA/EIA 568B and ClassD per ISO/IEC 11801

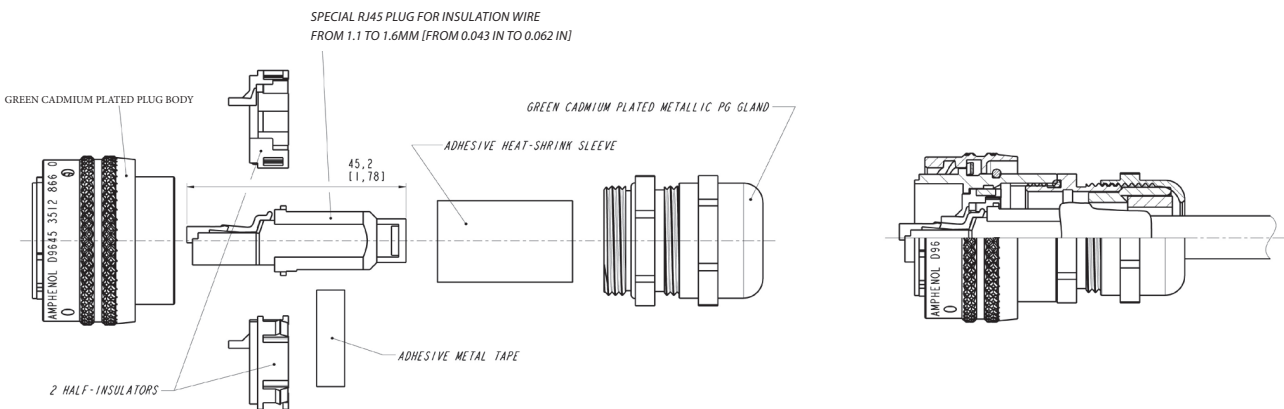

Part number	Plating	Part number
	Nickel - ROHS compliant	Kit39992NI
	Olive drab cadmium	Kit39992G



# RJ Field Receptacle with Self Closing Cap



This kit includes a receptacle and a Self Closing Cap which protects the RJ Field square flange receptacles (MIL-C-26482 type). This cap offers a protection against dust and water projections. A spring automatically closes the upper part of the cap when either the RJfield plug, USB or IEEE1394 cordset, or USB key are removed from the receptacle.

**Sealing level IP54**  
(Splash and dust Proof)

## RJF 21 X SCC

RJ45 version

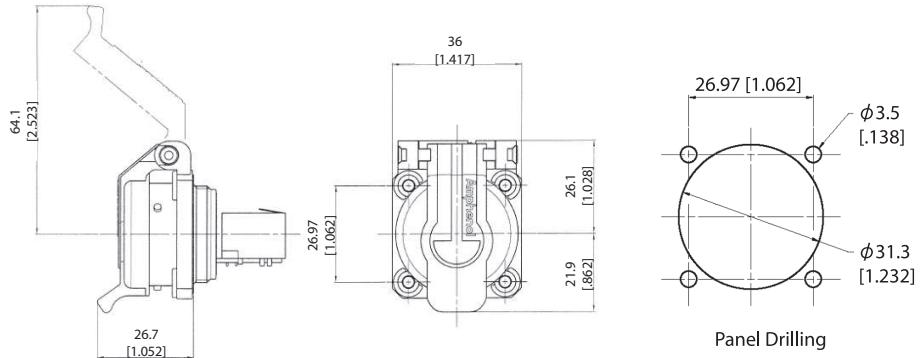

Part number *	Plating	Metallized insert (EMI)	Part number
	Black coating - ROHS compliant	No	RJF 21B SCC
	Nickel - ROHS compliant	Yes	RJF 21N SCC
	Olive drab cadmium	Yes	RJF 21G SCC

\* The part number includes the receptacle + the self closing cap

Remarks:

- the back termination is female RJ45
- it could be used with our RJF series plug (part number RJF6xx ► see page 17)

■ **Note:** Panel gasket with any of these receptacles: JE18 

## USBF 21 x SCC, USBBF 21 x SCC, & IEEE1394



**USB2.0 & 3.0 - A version**  
(see pages 94 & 107)



**USB-B version**  
(see page 118)



**IEEE1394 version**  
(see page 143)

# Mouser Electronics

Authorized Distributor

Click to View Pricing, Inventory, Delivery & Lifecycle Information:

## [Amphenol:](#)

[RJF21GSCC](#) [RJF2PEM2N00](#) [RJF2SA5G](#) [RJF7HA1B](#) [RJF2PE2N00](#) [RJF71RAN](#) [RJF2SB1N](#) [RJF2SD5G](#)  
[RJF2SC5N](#) [RJF2PE2B00](#) [RJF72N10100BTX](#) [RJF7HC1G](#) [RJF7PE2B05100BTX](#) [RJF7PE2G05100BTX](#) [RJF2SB1G](#)  
[RJF2SC1G](#) [RJF2SD1G](#) [RJF7SC1G](#) [RJF7SB1G](#) [RJF2PE2G15100BTX](#) [RJF7SB1RAN](#) [RJF7SC1B](#) [RJF7SC1N](#)  
[RJF7SD1G](#) [RJF7HA1N](#) [RJF7HC1B](#)