

AS85049/94 Mounting Flange, Full Perimeter

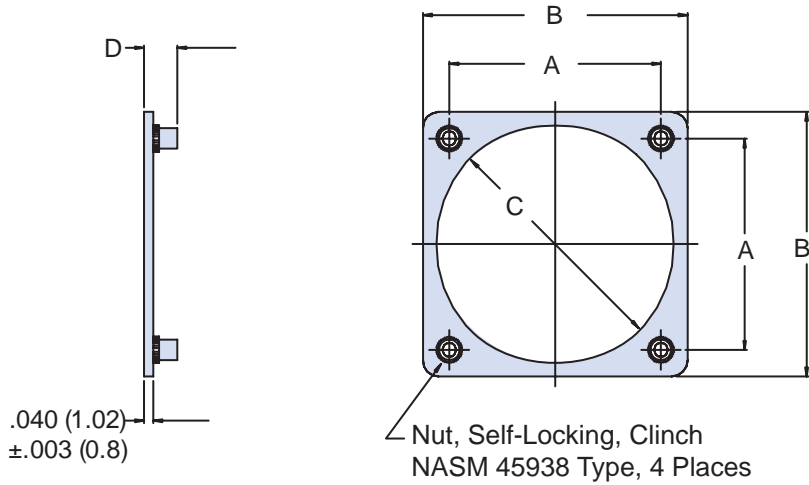

AS85049

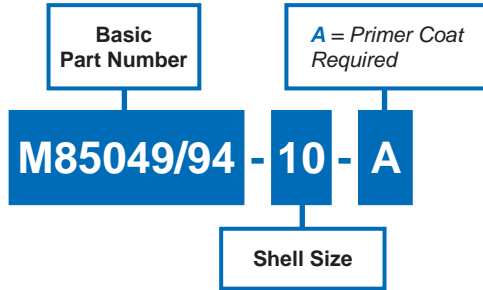

.040 (1.02)
±.003 (0.8)

TABLE I: Reference for Connector Shell Size

Shell Size	Thread UNJC-3B	A		B Max		C		D Max	
		±.015	(.38)			±.015	(.4)		
8	4-40	.594	(15.1)	.900	(22.9)	.570	(14.5)	.166	(4.2)
10	4-40	.719	(18.3)	1.034	(26.3)	.720	(18.3)	.166	(4.2)
12	4-40	.812	(20.6)	1.119	(28.4)	.845	(21.5)	.166	(4.2)
14	4-40	.906	(23.0)	1.213	(30.8)	.975	(24.8)	.166	(4.2)
16	4-40	.969	(24.6)	1.295	(32.9)	1.085	(27.6)	.166	(4.2)
18	4-40	1.062	(27.0)	1.421	(36.1)	1.210	(30.7)	.166	(4.2)
20	4-40	1.156	(29.4)	1.550	(39.4)	1.335	(33.9)	.166	(4.2)
22	4-40	1.250	(31.8)	1.680	(42.7)	1.470	(37.3)	.166	(4.2)
24	6-32	1.375	(34.9)	1.800	(45.7)	1.585	(40.3)	.183	(4.6)
25	6-32	1.500	(38.1)	1.910	(48.5)	1.658	(42.1)	.183	(4.6)

APPLICATION NOTES

1. Assembly identified with manufacturer's name and part number, space permitting.
2. For complete dimensions, see the applicable Military Specification.
3. Metric dimensions (mm) are in parentheses.

Dimensions in inches (millimeters) and are subject to change without notice.

B