



M.2-FMC adapter board [AB17-M2FMC]

Manual [Ver1.0E]

Introduction

Thank you for choosing M.2 – FMC adapter board [Part Number: AB17-M2FMC] (“adapter board” in this manual). This adapter board converts from 8 FMC Hi-Speed differential signals (DP0-DP7) into two 4-lane PCIe standard M.2 interface. This board can be applied to standard Intel or Xilinx FPGA evaluation board that mounts HPC (High Pin Count) FMC extension interface, and user can evaluate NVMe-IP core operation from DesignGateway.

There are two M.2 connectors on the component side of this adapter board, and can mount two 2280 or smaller size M.2 SSD. HPC-FMC connector is mounted on the solder side, and DP0-DP3 signals are assigned for Drive#1 while DP4-DP7 signals are assigned for Drive#2.

This adapter board furnishes reset circuit and low-jitter clock generator, so reset and clock signals are supplied to both FMC interface and M.2 SSD. In normal usage, SSD power is supplied from FMC 12V power source with on-board 12V-to-3.3V DC/DC regulator. However when SSD power consumption is too big to supply only from FMC, auxiliary power supply via 4pin ATX connector is available by OR-ed power supply mechanism. Two 3pin connectors are applicable for 12V fan power to cool SSD with heat sink.

The feature of the adapter board is as follows.

- HPC (High Pin Count) FMC extension adapter board.
- Supports two 2280-size (or smaller) M.2 SSDs.
- Power can be supplied either or both from FMC 12V or auxiliary ATX power source
- On-board On-Off power control switch.
- Two 12V fan power connectors that synchronize with SSD power switch.
- Mounts Low-jitter reference clock (100MHz default) source.
- Same clock is supplied to both SSD and FMC.
- Flexible hardware reset with manual reset function for FMC and SSD reset usage.

Board Outline

The adapter board size is 69mm width and 105mm length.
Following figure-1 and 2 shows component side and solder side respectively.

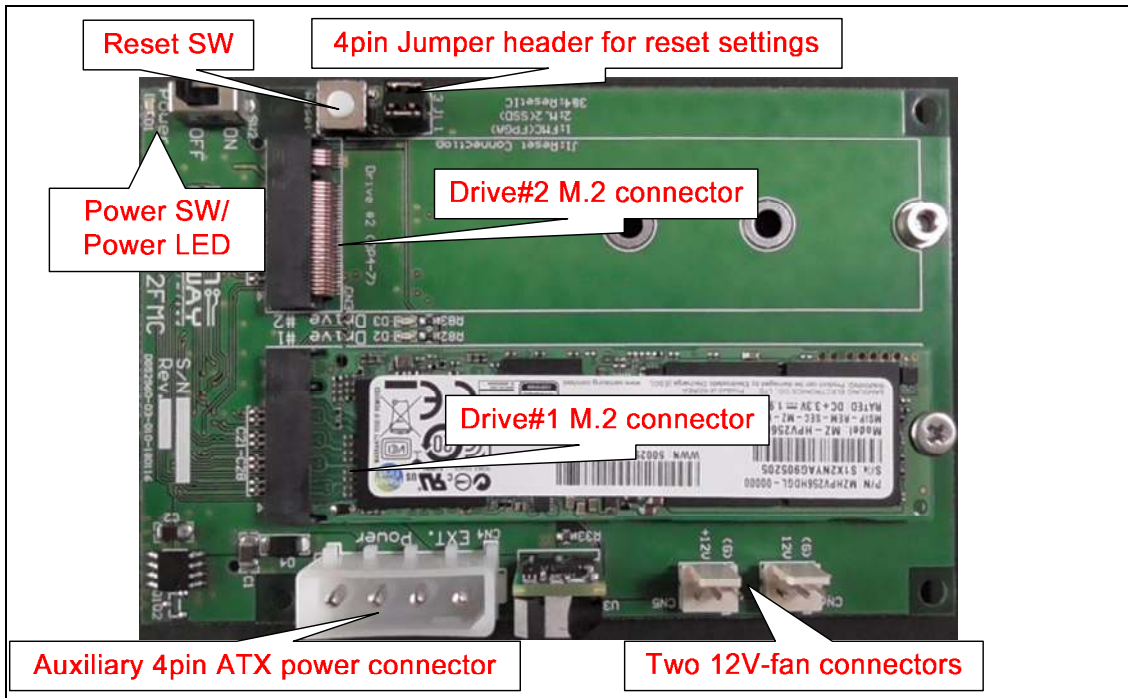

Figure-1: Board component side

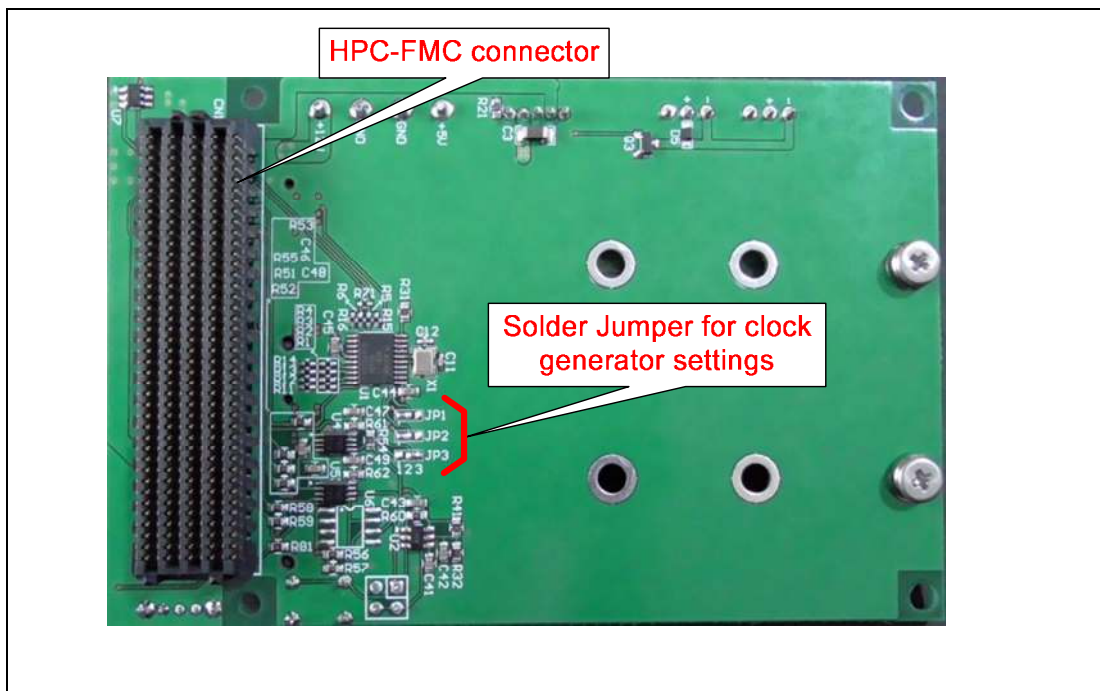

Figure-2: Board solder side

Jumper Setting

This adapter board mounts J1 (4pin) header, and also has 3 solder patterns of JP1-JP3 so that they can be set by the user. Each pin header, solder pattern and related circuit block are described below.

[1] J1 (4pin header)

J1 is 2x2 pin header shown in figure-3 below, and selects reset signal routings. Figure-3 also shows pin number definition. By using 2.54mm-pitch short plug, user can select following reset configuration. This adapter board mounts following reset IC (U2 which monitors 3.0V threshold at 3.3V power supply, and reset delay time is 100msec. When user press reset switch (SW1), it can manually generate reset signal.

IC Vendor: T.I Part Number: TPS3808G01DBV

J1 settings:

1-2 Short: Directly connect reset signal between FMC (FRST) and SSD (PERST).

1-3 Short: Connect reset output from Reset IC (U1) to FMC reset signal (FRST).

2-4 Short: Connect reset output from Reset IC (U1) to SSD reset signal (PERST).

(Refer to the schematic in this document for more detailed information.)

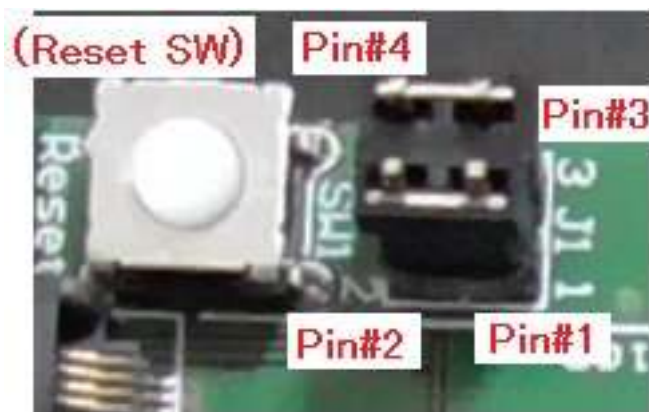

Figure-3: J1 pin header for PCIe reset

[2] JP1-JP3 (Solder pattern)

JP1-JP3 is solder pattern for clock parameter settings of clock generator IC, and setting description is shown at figure-4 below. This adapter board mounts following clock generator IC.

Vendor: IDT Part Number: IDT5V41236PGG

At JP1-JP3 pattern of figure-4, center pad is connected to S0-S2 pin of the clock generator respectively, and can set parameter by solder short to left side pad (Hi = Vcc) or right side pad (Lo=GND). Factory default setting is that JP1 and JP2 are set Hi and JP3 is set Lo, so that clock frequency is 100MHz and no SSC.

Clock signal standard for SSD Drive#1/#2 is PCIe standard HCSL, while clock for FMC is LVDS standard.

Spread Spectrum Selection Table

S2	S1	S0	Spread%	Spread Type	Output Frequency
0	0	0	-0.5	Down	100
0	0	1	-1.0	Down	100
0	1	0	-1.5	Down	100
0	1	1	No Spread	Not Applicable	100
1	0	0	-0.5	Down	200
1	0	1	-1.0	Down	200
1	1	0	-1.5	Down	200
1	1	1	No Spread	Not Applicable	200

JP3 JP2 JP1 **Default setting** →

Figure-4: JP1-JP3 solder pattern for clock generator setting

Power Supply and Fan

Power of SSD and this adapter board is supplied from 12V of FMC (FMC pin# C35 and C37), and on-board DC/DC regulator (U3) generates 3.3V for SSD and some part on this adapter board. In FMC specification, 12V of FMC can supply up to 2A (maximum 1A per one pin), so that assume DC/DC efficiency is 90%, 6.5A at maximum current supply is possible for 3.3V. However, some latest NVMe SSD consumes more than 3A during operation so that **6.5A@3.3V** is critical when two NVMe SSDs are mount on this adapter board. In such power shortage case, user can connect auxiliary external 12V power via 4pin ATX connector in parallel of 12V from FMC because this adapter board use OR-ed power supply system.

3.3V power supply for SSD is controlled by on-board On-Off power switch, and CN5/CN6 for 12V fan is also synchronized with power switch, so that heat sink with cooling fan is available.

Figure-5 below shows M.2 SSD and heat sink with cooling fan.

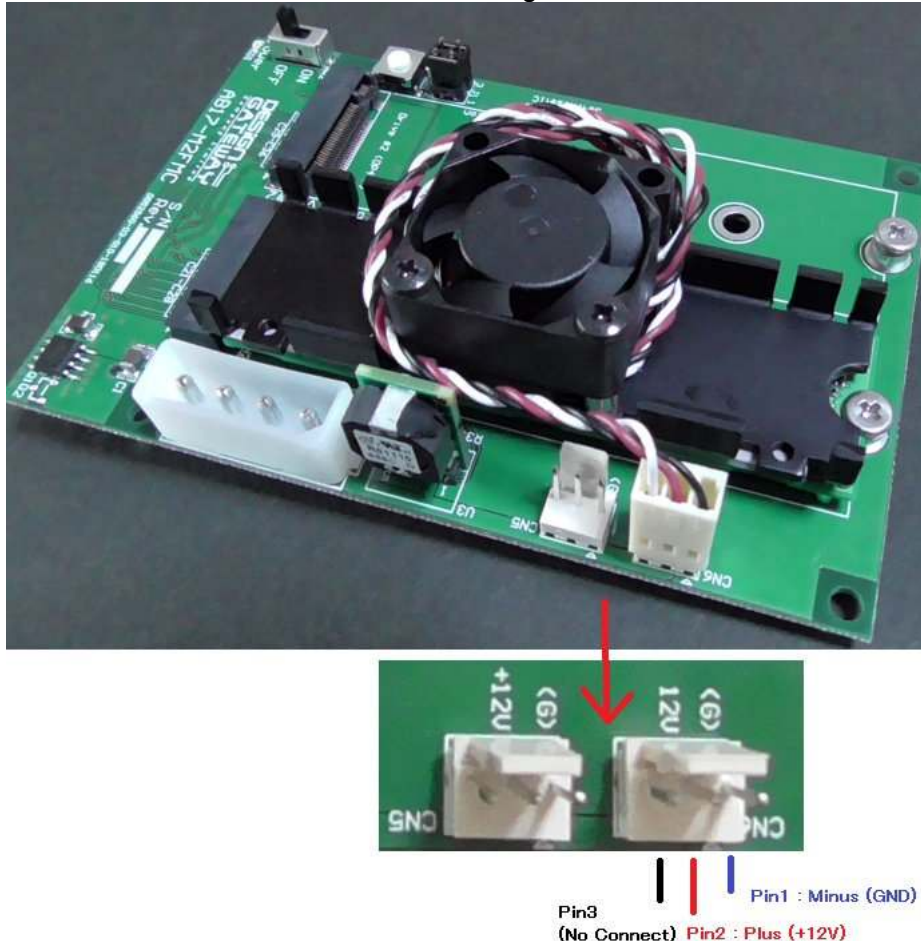

Figure-5: M.2 SSD and heat sink with cooling fan (fan power from CN5/6 connector)

Example product of M.2 heat sink with cooling fan is as follows.

Vendor : ADATA

Product: XPG STORM RGB M.2 2280 SSD heatsink

URL: <http://www.xpg.com/us/feature/494>

Note that some fan connector needs rework to adjust pin position assignment.

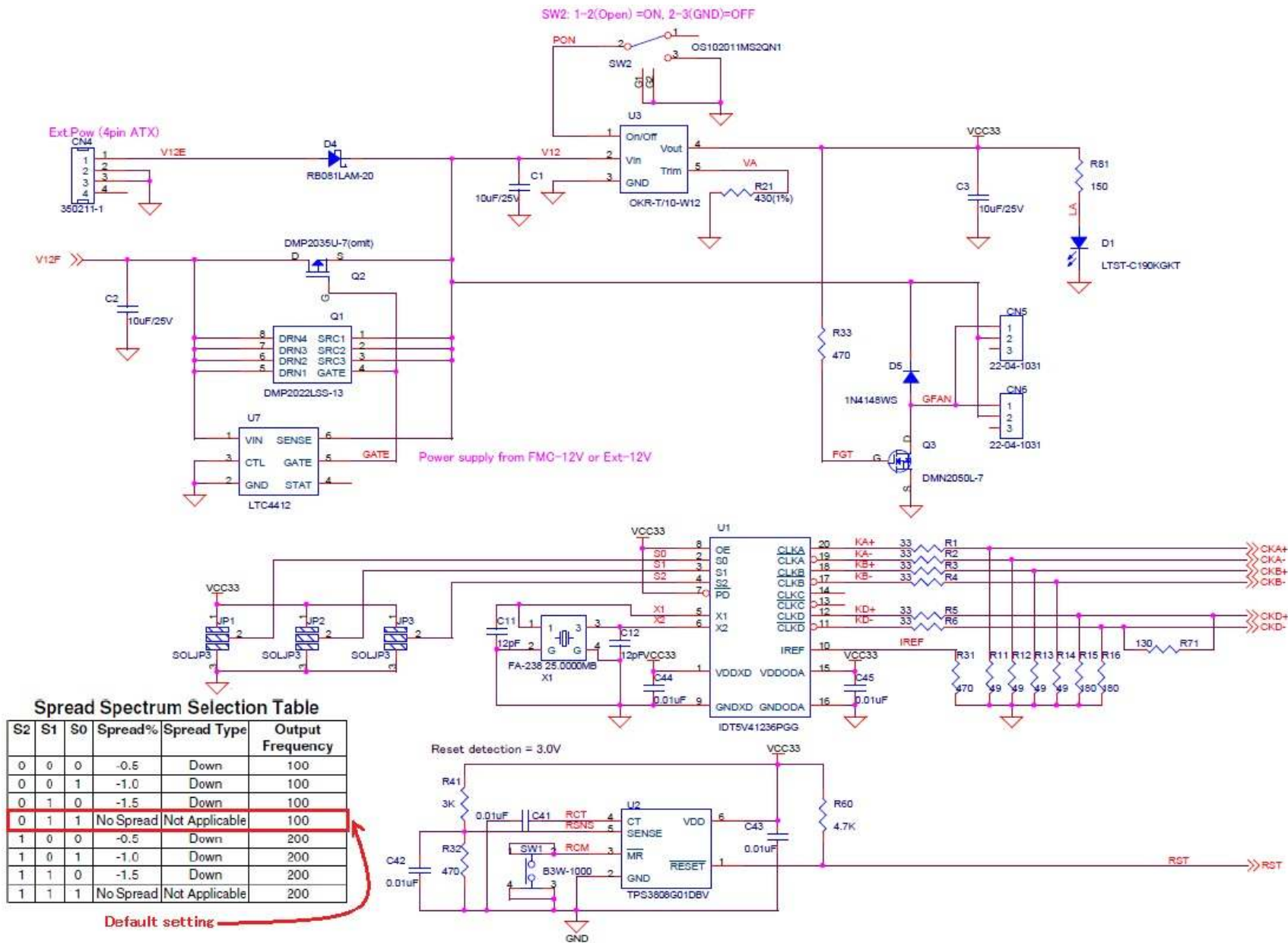

Spread Spectrum Selection Table

S2	S1	S0	Spread%	Spread Type	Output Frequency
0	0	0	-0.5	Down	100
0	0	1	-1.0	Down	100
0	1	0	-1.5	Down	100
0	1	1	No Spread	Nct Applicable	100
1	0	0	-0.5	Down	200
1	0	1	-1.0	Down	200
1	1	0	-1.5	Down	200
1	1	1	No Spread	Nct Applicable	200

Default setting

Figure-6: Adapter board schematic (1/2)

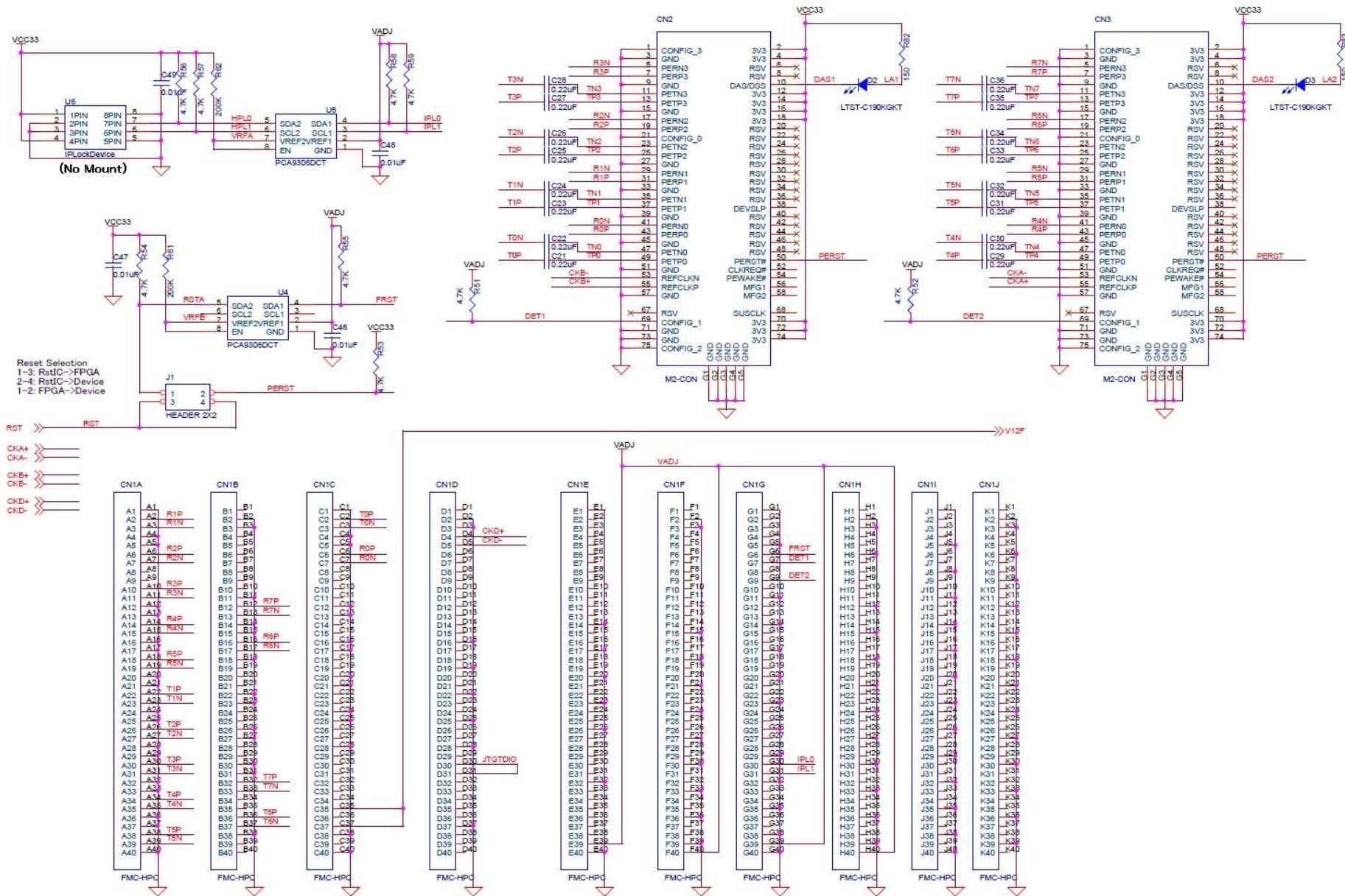

Figure-7: Adapter board schematic (2/2)

Disclaimer

The manufacturer of the product limits liability in following situation or use.

- Any damage to the FPGA evaluation board connected with the adapter board.
- Any damage to the SSD device connected with the adapter board.
- DesignGateway does not always guarantee M.2 operation between FPGA board and M.2 SSD device via the adapter board.

[Contact]

URL : <http://www.design-gateway.com>

Email : info@design-gateway.com

Revision History

Revision	Date	Description
1.0J	2-Mar-2018	Initial Japanese manual
1.0E	2-Mar-2018	Initial English manual

Mouser Electronics

Authorized Distributor

Click to View Pricing, Inventory, Delivery & Lifecycle Information:

[Design Gateway:](#)

[AB17-M2FMC](#)