



EKF



TECHNICAL MANUAL

HMI PRO-Screen

1 DESCRIPTION AND APPLICATION

The HMI PRO-Screen is a human machine interface device used to create monitoring systems and control technological processes.

The device settings and programming shall be made with the PRO-Screen master software.

The HMI PRO-Screen fits all industry applications based on the work of programmable logic controllers, automation control systems and industrial automation. It can work in conjunction with devices from any producers. The HMI PRO-Screen complies with the requirements of IEC 61131-2:2017.

2 TECHNICAL DATA

Table 1 - Main characteristics

Parameter	Value				
	RSC-4	RSC-7	RSC-7E	RSC-10E	RSC-15E
Hardware characteristics					
Processor	720MHz ARM9	600MHz ARM Cortex-A8			1G ARM Cortex A8
Flash-memory	1 GB	128 MB			256 MB
Program memory	64 MB	128 MB			512 MB
Real Time Clock (RTC)	Embedded				
Display					
Type	4-wire resistive TFT LCD				
Size	4,3" (16:9)	7" (16:9)	7" (16:9)	10,1" (16:9)	15,6" (16:9)
Illumination	LED				
Resolution	800×480	1024×600			1920 ×1080
Brightness	250 cd/m ²	400 cd/m ²			250 cd/m ²
Time between failures for illumination, min.	50 000 h at temperature of 25 °C				

Table 1 continued

Parameter	Value				
	RSC-4	RSC-7	RSC-7E	RSC-10E	RSC-15E
Connectors and interfaces					
COM-ports	COM1: RS232/ RS485/ RS422 COM3: RS232	COM1/COM3: RS232/RS485/RS422 COM2: RS485			COM1/ COM3: RS232/ RS485/ RS422 COM2: RS485/ RS422
Ethernet	No		10M/100M Ethernet		
Supported protocols	Modbus RTU (Master/Slave), Modbus ASCII (Master)		Modbus RTU (Master/Slave), Modbus ASCII (Master), Modbus TCP (Master/Slave)		
USB Device	1xUSB Slave 2.0	1xUSB Slave 2.0, 1xUSB Host 2.0			
Port for SD-card	No	Available			
Power supply					
Type of supply voltage	Constant 24 V				
Range	9...28 V				18...28 V
Power consumption, max.	2.5 W	7 W	10 W	18 W	
General characteristics					
Degree of protection by IEC 60529	IP65 - front-side IP20 - connector-side				
Operating temperature	0...50 °C				

Table 1 continued

Parameter	Value				
	RSC-4	RSC-7	RSC-7E	RSC-10E	RSC-15E
Operating humidity	10...90 % (no condensation)				
Storage temperature	-20...+60 °C				
Housing material	ABS+PC				Aluminium
Weight	0,3 kg	0,56 kg		0,92 kg	2,25 kg

3 TYPE CODE

RSC - X1 X2

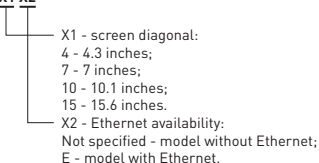

4 OVERALL DIMENSIONS

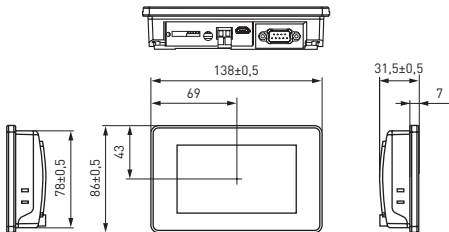

Fig. 1 - RSC-4 Overall dimensions

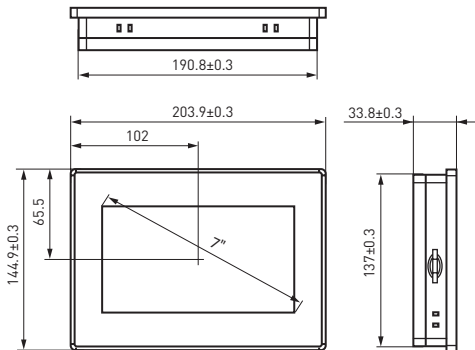

Fig. 2 - RSC-7 and RSC-7E Overall dimensions

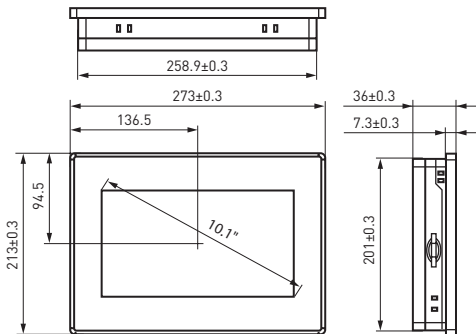

Fig. 4a - RSC-10E Overall dimensions

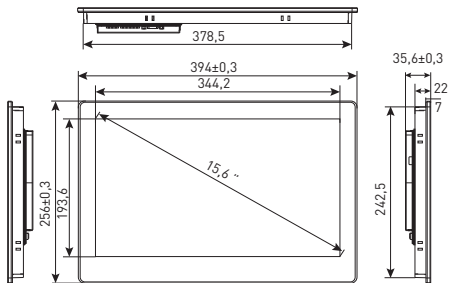

Fig. 4a - RSC-15E Overall dimensions

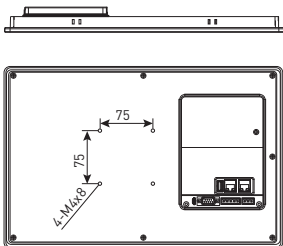

Fig. 4b - VESA Installation dimensions for RSC-15E

5 INSTALLATION

The HMI is designed to be installed in the enclosure. It can be installed at any tilting angle for user comfort.

Protect the back panel of the device from moisture and dirt. The front panel is protected by a rubber seal.

HMI Installation:

1. Place the HMI into the mounting opening of the enclosure.
2. Insert the fasteners into the HMI housing.
3. Tighten the mounting screws.

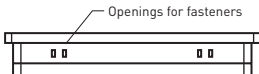

Fig. 5 - HMI Installation

The HMI RSC-15E can be mounted to a wall with a bracket. For this purpose, there is VESA 75x75 mount on the back panel of the HMI (mounting screws included).

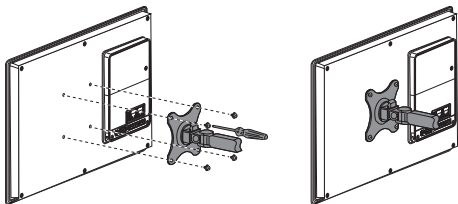

Fig.6 - Bracket mount

6 CONNECTION

Power supply

The HMI shall be powered from distributed power mains with 24 V DC rated voltage or from a local power supply of suitable capacity. When powered from a distributed network, install a surge protector in front of the HMI. The power connection diagram is shown in Tables 2, 3.

Connectors and interfaces

The HMI has various peripheral devices. Their description and wiring diagrams are given in fig. 7.

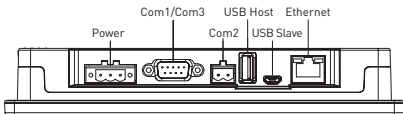

Fig.7 PRO-Screen Back side view

Table 2 - RSC-4, RSC-7, RSC-7E, RSC-10E Power and Interface Connectors Description









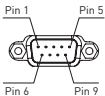

Power supply (left to right)		
	Pin1	FG
	Pin2	0V
	Pin3	DC24V
COM port DB9 (COM1/COM3)		
	Pin1	Rx-(B)
	Pin2	RxD (COM1 RS232)
	Pin3	TxD (COM1 RS232)
	Pin4	Tx-
	Pin5	GND
	Pin6	Rx+(A)
	Pin7	RxD (COM3 RS232)
	Pin8	TxD (COM3 RS232)
	Pin9	Tx+
PORT RS-485 (COM2)		
	Pin1	A+ (COM2 RS485)
	Pin2	B- (COM2 RS485)
Ethernet Port		
	RJ45	Communication with controller or server
USB		
	USB Type A	USB drive connection
	MicroUSB	Project loading and debugging

Table 3 - RSC-15E interface and power connector description

Power supply (left to right)		
	Pin1	DC24V
	Pin2	0V
	Pin3	FG
COM port DB9 (COM1/COM3)		
	Pin1	Rx-(B)
	Pin2	RxD (COM1 RS232)
	Pin3	TxD (COM1 RS232)
	Pin4	Tx-
	Pin5	GND
	Pin6	Rx+(A)
	Pin7	RxD (COM3 RS232)
	Pin8	TxD (COM3 RS232)
	Pin9	Tx+
Port RS-485/422 (COM2)		
	Pin1	Rx+(A)
	Pin2	Rx-(B)
	Pin3	GND
	Pin4	Tx+
	Pin5	Tx-
Ethernet Port		
	RJ45	Communication with controller or server
USB		
	USB Type A	USB drive connection
	MicroUSB	Project loading and debugging

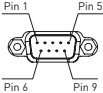
7 DELIVERY SCOPE

HMI - 1 pc.;

Fastening kit - 1 pc.;

Technical manual - 1 pc.

8 SAFETY REQUIREMENTS

Do not operate HMI's with visual mechanical damage.

Only qualified personnel is authorized to operate the device.

Failure to follow the guidelines herein may result in severe injuries and equipment damage.

9 TRANSPORTATION AND STORAGE

The HMI's can be transported by any means of enclosed transport that prevents the packed products from exposure to mechanical impacts and vibrations. The HMI's shall be stored indoors in the original package at the ambient temperature from -20...+60 °C.

10 MANUFACTURER'S WARRANTY

The manufacturer guarantees the products comply with the declared characteristics, provided that the consumer follows the operation, transportation and storage conditions.

Warranty period: 3 years from the date of sale specified in section 13 herein.

Shelf life: 3 years from the date of manufacture specified in section 12 herein.

Service life: 10 years.

Manufacturer: For information, refer to the product package.

Importer and EKF trademark service representative:

EKF ELECTRICAL SOLUTION – FZCO, Dubai Silicon Oasis, DDP, Building A2, Dubai, United Arab Emirates.

Importer and EKF trademark service representative on the territory of the Russian Federation: OOO «Electroresheniya», Otradnaya st., 2b bld. 9, 5th floor, 127273, Moscow, Russia. Tel.: +7 (495) 788–88–15.

Importer and EKF trademark service representative on the territory of the Republic of Kazakhstan: TOO «Energoresheniya Kazakhstan», Kazakhstan, Almaty, Bostandyk district, Turgut Ozal st., 247, apt 4.

11 DISPOSAL

Life-expired and failed products shall be disposed of in compliance with the national and local laws and regulations in force.

To dispose of the product, send it to an authorized company for recycling in compliance with the national and local laws and regulations in force.

12 CERTIFICATE OF ACCEPTANCE

The HMI PRO-Screen has been approved for operation.

Quality control stamp

Date of manufacture «__» _____ 20__г.



13 NOTE OF SALE

Date of sale «__» _____ 20__г.

Seller's signature

Seller's stamp



www.ekfgroup.com

v2