

REV.	DATE	DESCRIPTION
NC	12/22/03	INITIAL RELEASE

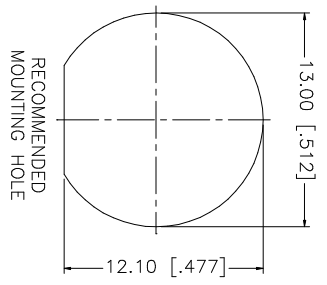
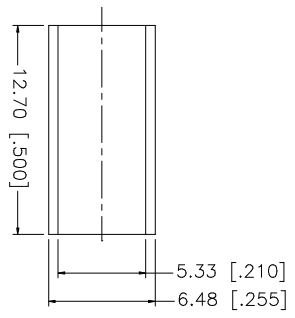
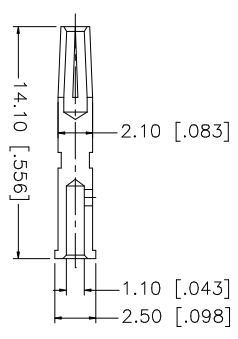
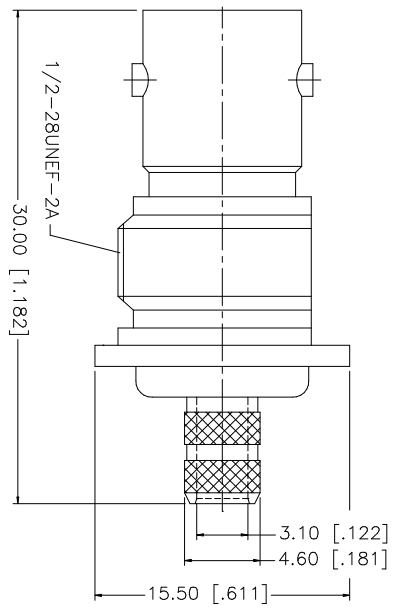
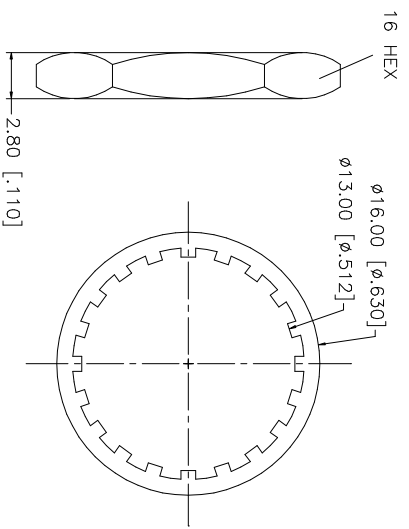
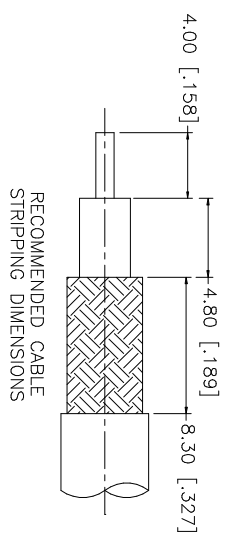

8																			
7																			
6	FERRULE	COPPER	NICKEL	1															
5	HEX NUT	BRASS	NICKEL	1															
4	LOCK WASHER	BRASS	NICKEL	1															
3	CONTACT PIN	PHOS. BRONZE	GOLD	1															
2	INSULATOR	TEFLON	NATURAL	1															
1	BODY	BRASS	NICKEL	1															
DESCRIPTION		MATERIAL		FINISH		QTY													
UNLESS OTHERWISE SPECIFIED DIMENSIONS ARE IN MILLIMETERS. DIMENSIONS IN [ ] ARE IN INCHES AND FOR CUSTOMER REFERENCE ONLY.										UNLESS OTHERWISE SPECIFIED TOLERANCES FOR MILLIMETERS ARE:									
0.5 - 8mm ± 0.20mm										0.5 - 8mm ± 0.20mm									
8 - 30mm ± 0.40mm										8 - 30mm ± 0.40mm									
30 - 120mm ± 0.50mm										30 - 120mm ± 0.50mm									
UNLESS OTHERWISE SPECIFIED TOLERANCES FOR INCHES ARE:										UNLESS OTHERWISE SPECIFIED TOLERANCES FOR INCHES ARE:									
.020 - .315 = ± 0.007"										.020 - .315 = ± 0.007"									
.315 - 1.180 = ± 0.015"										.315 - 1.180 = ± 0.015"									
1.180 - 4.724 = ± 0.020"										1.180 - 4.724 = ± 0.020"									
DO NOT SCALE DRAWING																			
APPROVALS					DATE					CAD FILE									
DRAWN G.R.S.					12/22/03					C:/112/112236.DWG									
CHECKED										PART DESCRIPTION									
ISSUED										BNC BULKHEAD CRIMP JACK									
SHEET 1 OF 1										ISOLATED GROUND (FOR RG-58/U)									
										PART NO. 112236									
										DWG. NO. 112236.DWG									
										REV. NC									
										SIZE A									
										SCALE NA									

**Amphenol Connex**

# Mouser Electronics

Authorized Distributor

Click to View Pricing, Inventory, Delivery & Lifecycle Information:

[Amphenol:](#)

[112236](#)