

Breather/Filter Caps

Standard and Pressure Relief

Weights

Standard type: 0.277 kg

Pressure Relief type: 0.333 kg

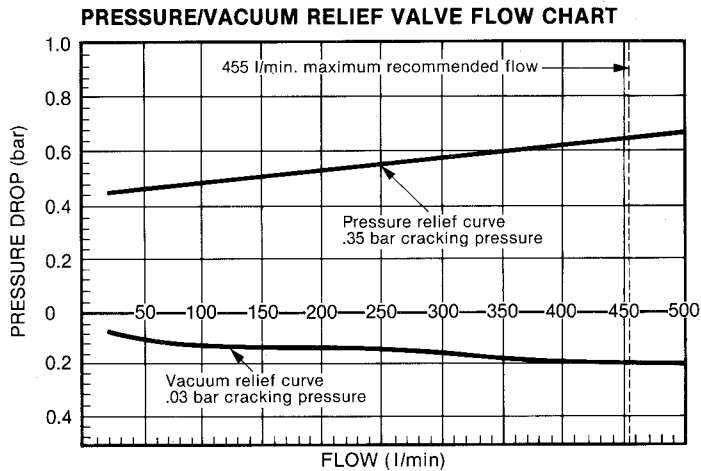
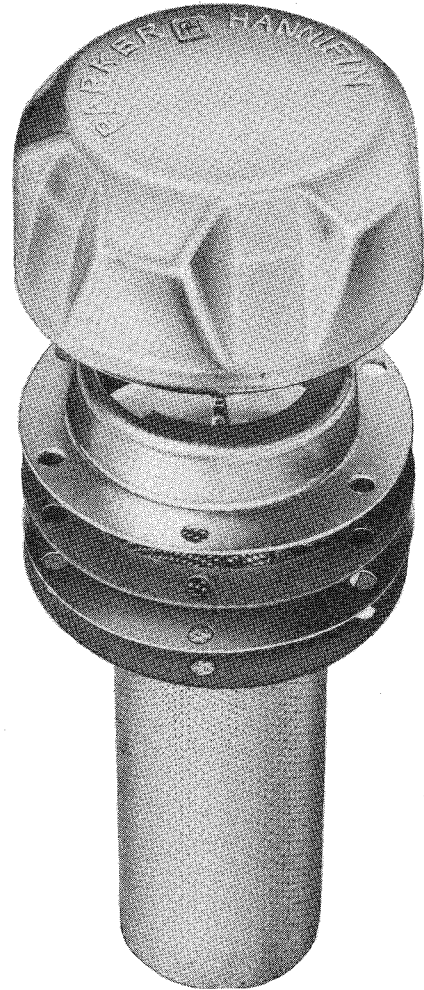

Symbols

Standard

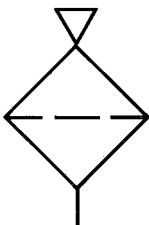

With relief valve

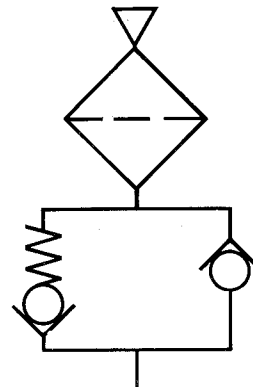

- Maximum flow rate 455 l/min
- Breather Elements 10 or 40 micron
- Filter Strainer 30 mesh
- Maximum pressure drop 0.014 bar across clean element
- Suitable for use with mineral oil and diesel fuel
- Plated steel components to resist corrosion

- Optional relief valve to safeguard against excessive tank pressure to within 0.35 bar or maintain tank vacuum to within 0.03 bar
- Maximum working temperature for pressure relief valve: 80°C
- Optional locking tab available
- Supplied complete with mounting gaskets and self-tapping screws

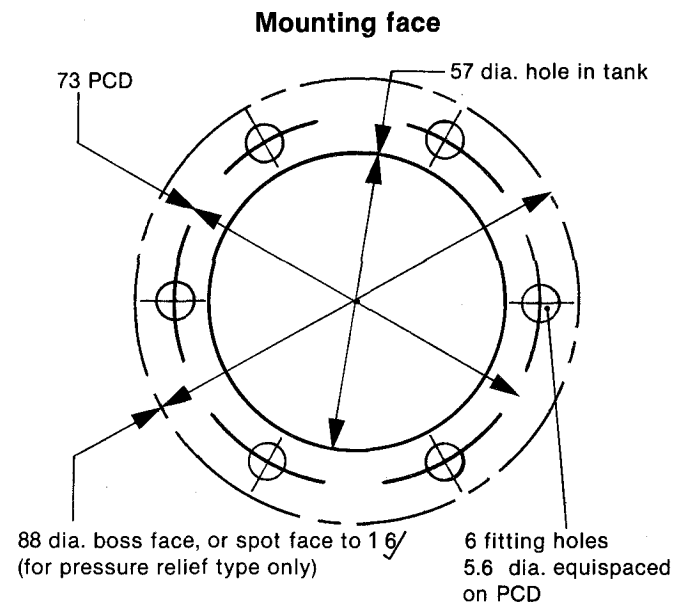
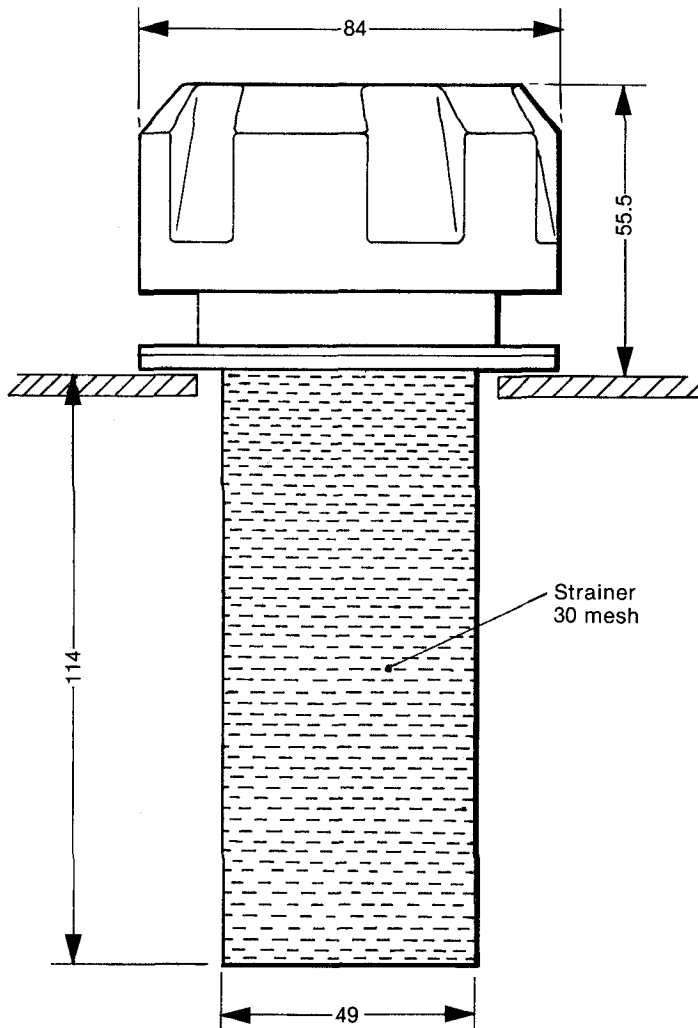

ORDERING INFORMATION Specify part number as shown below

Description	Part number
Standard breather/filler with 10 micron breather element	H00153-001
Standard breather/filler with 40 micron breather element	H00153-003
Pressure relief breather/filler with 10 micron breather element	H00153-002
Pressure relief breather/filler with 40 micron breather element	H00153-004