

THESE DRAWINGS ARE THE PROPERTY OF QUALTEK ELECTRONICS AND NOT TO BE REPRODUCED FOR OR COMMUNICATED TO A THIRD PARTY WITHOUT THE EXPRESS WRITTEN PERMISSION OF AN OFFICER OF QUALTEK ELECTRONICS.

REVISION			
REV.	DESCRIPTION	DATE	APPROVED
B	RoHS Compliancy	06-01-06	DP
C	Notes Updated	08-09-07	DP
D	Added UL and CSA file number	01-13-10	LY
E	Reduction in Size of the Insulator Between Terminals	05-05-16	LY
F	Updated Approvals	08-15-19	LY

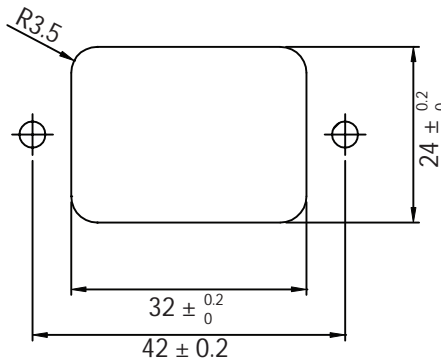

PANEL CUTOUT

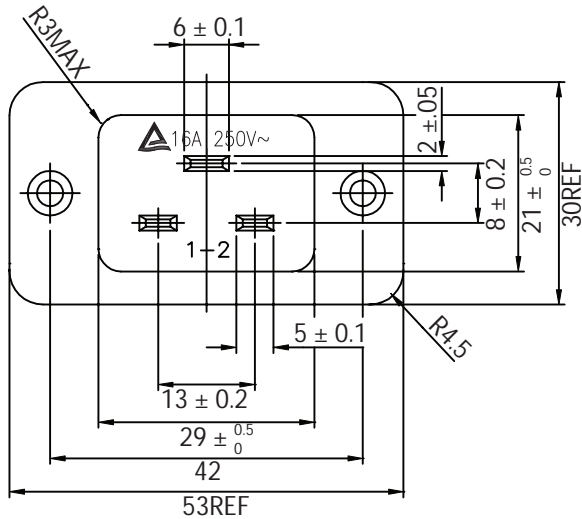
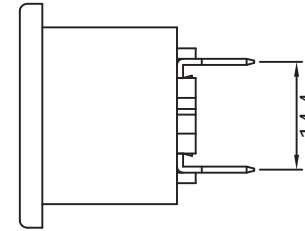
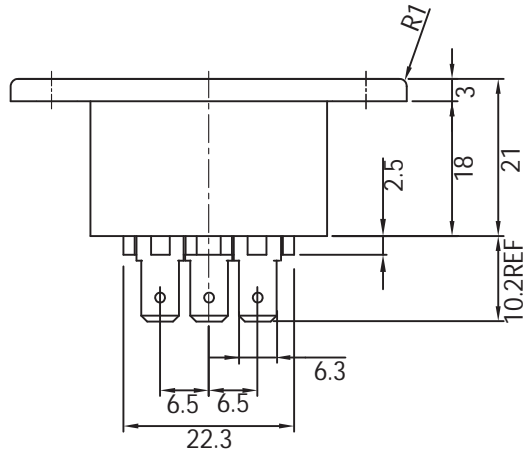
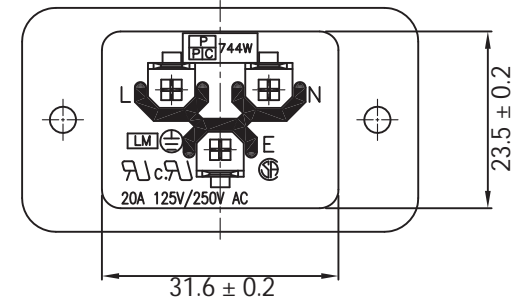

NOTES:

RATING:

UL, CSA: 20A 125V AC/ 20A 250V AC
 TUV: 16A 250V AC
 APPROVALS: UL, CSA, TUV
 UL FILE: E139592
 CSA FILE: LR75389
 IEC 60320 C20
 BODY COLOR: BLACK
 RoHS COMPLIANT

CONTROLLED

Dim range (mm)		Tolerance +/- (mm)	Qualtek Electronics Corp. PPC DIVISION		
0-1		0.15	Part Number: 744W-00/04		RoHS Compliant
1-6		0.20	Description: AC RECEPTACLE		
6-18		0.30	UNIT: mm		REV. F
18-50		0.50	Drawn / Date	Checked / Date	Approved / Date
50-120		0.70	B.Zhang	02-26-03	JJH / 02-26-03
120-250		0.90			
250-500		1.20			

Mouser Electronics

Authorized Distributor

Click to View Pricing, Inventory, Delivery & Lifecycle Information:

[Qualtek:](#)

[744W-00/04](#)