

ISS.	AMEND	DATE
1	ISSUED	16/02/18

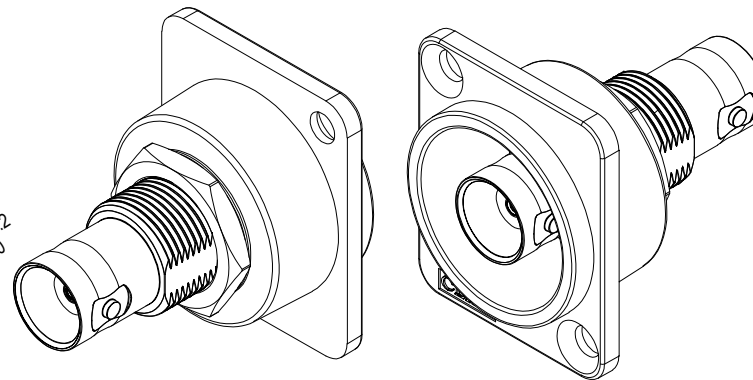

ITEM	DESCRIPTION	MATERIAL	FINISH
1	FRAME	POLYAMIDE UL94 V2	BLACK
2	NUT	BRASS	NICKEL
3	WASHER	BRASS	NICKEL
4	BNC	ALLOY	NICKEL
5	BNC INSULATION	POM	BLACK

CP303090 - CSK HOLES

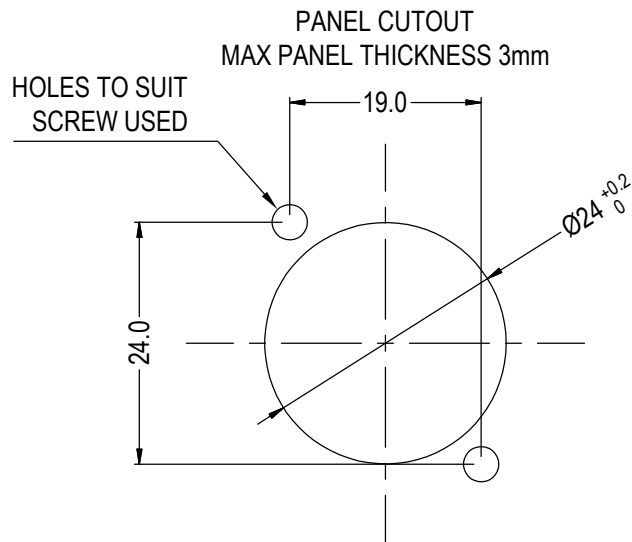
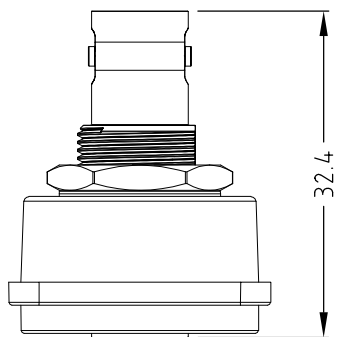
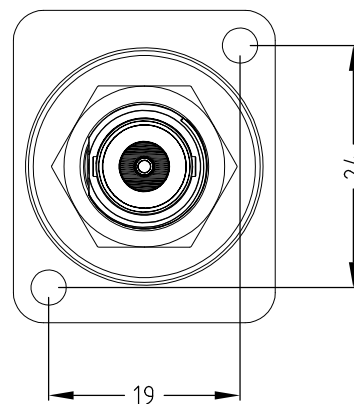
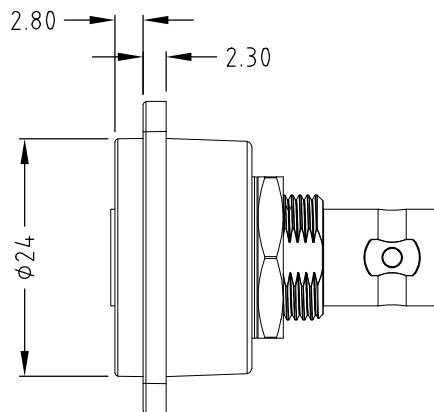
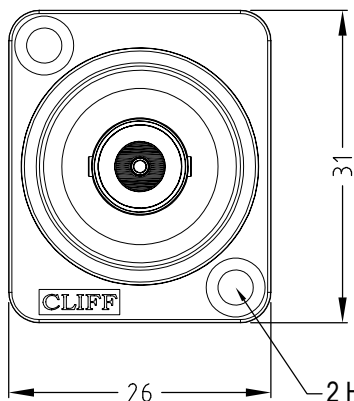

2 HOLES: $\varnothing 3.50$ CSK $82^\circ \times \varnothing 5.85$
'X' VERSION HAS $\varnothing 2.50$ HOLES.

VARIANTS	
PART NO.	HOLE DETAILS
CP303090	HOLE $\varnothing 3.50 \times$ CSK $82^\circ \times \varnothing 5.85$
CP303090X	PLAIN HOLE $\varnothing 2.50$

CP303090X - $\varnothing 2.50$ PLAIN HOLES

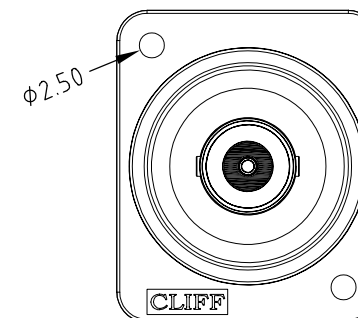

RoHS
COMPLIANT

TOLERANCE
NO DEC. PLACE \pm
1 DEC. PLACE \pm
2 DEC. PLACE \pm
HOLE $\varnothing \pm$
ANGLES \pm
UNLESS
OTHERWISE STATED

DO NOT SCALE

Cliff Electronic Components Ltd.

76 Holmethorpe Avenue, Holmethorpe Industrial Estate,
Redhill, Surrey, RH1 2PF, England, UK
Tel: 01737-771375 Fax: 01737-766012 Website: www.cliffuk.co.uk

DIMENSIONS IN MILLIMETERS UNLESS OTHERWISE STATED. WORK TO DIMENSIONS. REMOVE ALL BURRS. IF IN DOUBT ASK.

3rd ANGLE PROJECTION:

MATERIAL: SEE TABLE

FINISH: SEE TABLE

DRAWN: T.J.O.

APPROVED: D.P.J.

TITLE: XRP12 BNC 50 OHM

DRWG. No. **CP303090**

FORM: A4DRWGf