

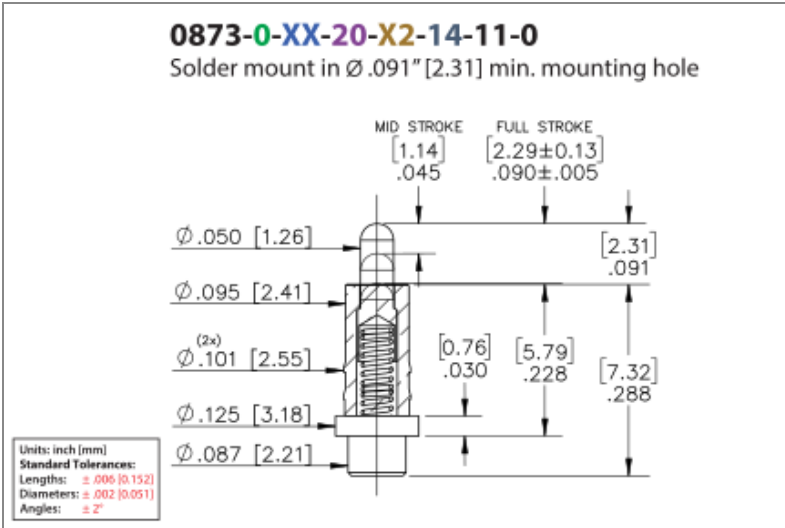

PRODUCT NUMBER: 0873-0-15-20-82-14-11-0

www.mill-max.com  
DATA SHEET



## 0873-0-15-20-82-14-11-0 SPECIFICATIONS

General Info	
<b>Description<sup>1</sup>:</b>	Through Hole Mount Spring-Loaded Pin
<b>Plunger Type:</b>	Round
<b>Mounting Feature<sup>2</sup>:</b>	Through-Hole Solder Mount
<b>Mounting Hole:</b>	.091" (2,311mm)
<b>Initial Height:</b>	.379" (9,627mm)
<b>Stroke:</b>	.090" (2,286mm)
<b>Packaging:</b>	Packaged in Bulk
<b>RoHS<sup>3</sup>:</b>	Yes
<b>Product Lifecycle<sup>4</sup>:</b>	Active

Materials
<b>Shell Material<sup>5</sup>:</b> Brass Alloy
<b>Shell Plating<sup>6</sup>:</b> 20 $\mu$ " Gold over Nickel
<b>Spring Plating<sup>7</sup>:</b> 10 $\mu$ " Gold over Nickel

Technical Specs	
<b>Durability:</b>	100,000 to 1,000,000 Cycles @ Mid-Stroke
<b>Operating Temperature Range<sup>8</sup>:</b>	-55/+125° C
<b>Current Rating<sup>9</sup>:</b>	See Spring Specifications Below
<b>Contact Resistance<sup>10</sup>:</b>	See Spring Specifications Below
<b>Shock<sup>11</sup>:</b>	No Elect. Discontinuity > 1 $\mu$ s @ 50g
<b>Vibration<sup>12</sup>:</b>	No Elect. Discontinuity > 1 $\mu$ s @ 10-2000HZ, 20 G

## NOTES:

1. Standard Tolerances:  
Lengths +/- .006" (0,15)  
Diameters: +/- .002" (0,051)  
Angles: +/- 2°
2. For through-hole solder mounting of this part, the suggestion is to make the finished hole size, at its minimum, .004" larger than the diameter being soldered into the mounting hole.
3. Mill-Max products labeled with the RoHS symbol are compliant with all three ROHS Directives. All of our products previously described as RoHS (2002/95/EC) and RoHS-2 (2011/65/EC) are also compliant with RoHS-3 (2015/863/EU).
4. Part is Active and in Production, No Scheduled Obsolescence
5. Brass Alloy 360 per ASTM B 16, or 385 per ASTM B455
6. GOLD per ASTM B 488, Type 1 (99.7% min. gold), Code C (130-200 HK {Knoop hardness}); NICKEL per ASTM B 689, Type 2 (Bright)
7. GOLD per ASTM B 488, Type 1 (99.7% min. gold), Code C (130-200 HK {Knoop hardness}), NICKEL per ASTM B 689, Type 2 (Bright)
8. Storage per IEC 60512-11-(4,9,10,12) and peak operating temperature per IEC 60512-5-2, Test 5b
9. Per IEC 60512-5-2; Current Carrying Capacity; Current Derating
10. Per EIA-364-23C: Low Level Contact Resistance.
11. Per IEC 60512-6-3: Test 6c: Shock
12. Per IEC 60512-6-4: Test 6d: Vibration (sinusoidal)

## ADDITIONAL PARTS, PACKAGING, & ASSEMBLY INFO

### 0873-0-57 Tape & Reel Details

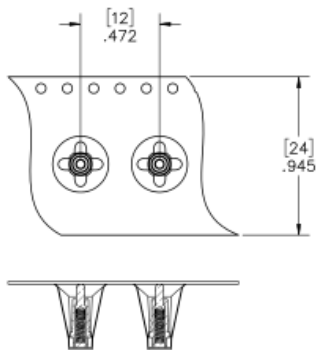

## SPRING:

<b>#82 SPRING</b> HIGH FORCE SPRING	Full Stroke Capability : .090"± .005" [2,29 ± 0,127]
Spring Material : Stainless Steel 302	Force @ Mid. Stroke : 120 g ± 20 g
Mid. Stroke : .045" [1,14]	Initial Force (Pre-Load) : 25 g

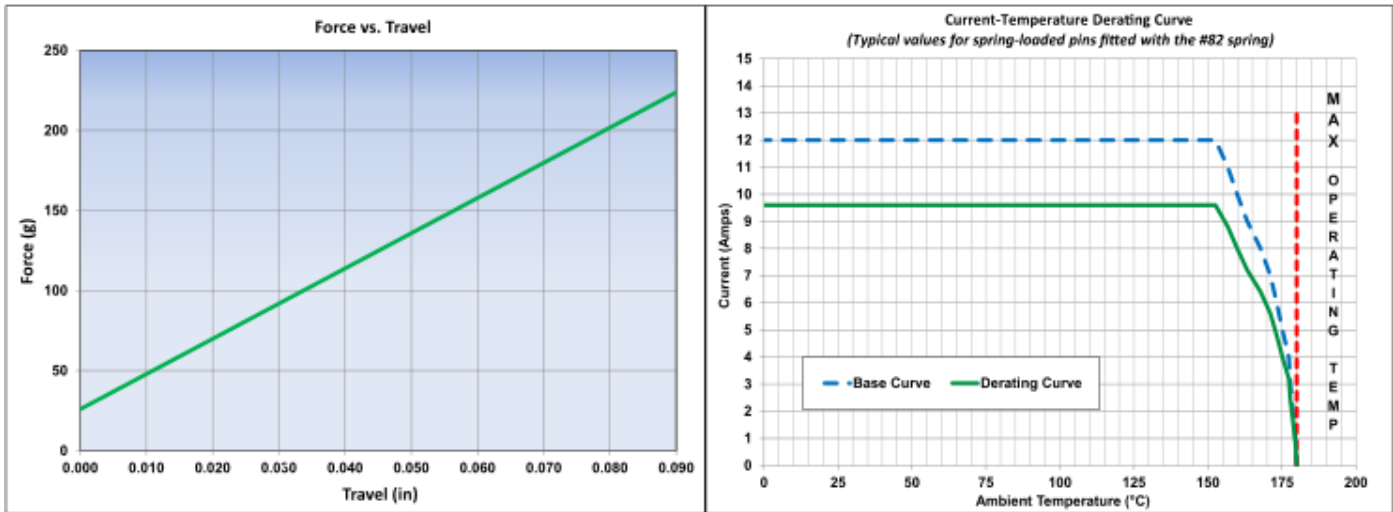

The stroke, force and current rating values are measured using spring pins with an internal construction per the design specification. Individual spring pin performance may vary from these values based on design differences.

Material	Stainless Steel	Grams Force	120
Max Stroke	0.09	Maximum Current	12A @ 30° C Temp. Rise
Maximum Operating Temp @ Max Current	150.00° C	20% De-rated Maximum Current	9.60A
Contact Resistance	20.00mΩ Max		

## ADDITIONAL NOTES AND SPECIFICATIONS

In the interest of improved design, quality and performance, Mill-Max reserves the right to make changes in its specifications without prior notice. Specifications and tolerances are provided wherever possible. The tolerance on dimensions of critical to function features is typically held tighter than the stated standard tolerances, such as press-fits, holes and lengths affecting the coplanarity of SMT products. Due to the wide variety of interconnects Mill-Max offers, the specific tolerances vary from product to product. If you need information regarding the tolerance of a particular part, please contact Technical Services.

## RELATED LINKS AND DOCUMENTS

Engineering Notebook: ( <https://www.mill-max.com/engineering-notebooks/introduction-to-spring-loaded-pogo-pins-connectors> )

Environmental Compliance: ( <https://www.mill-max.com/rohs> )