

THIS DRAWING IS UNPUBLISHED. RELEASED FOR PUBLICATION
 © COPYRIGHT - By - ALL RIGHTS RESERVED.

LOC	DIST	REVISIONS					
CM	00	P	LTR	DESCRIPTION	DATE	DWN	APVD
		G1		REVISED PER ECO-11-004820	11MAR11	RK	HMR

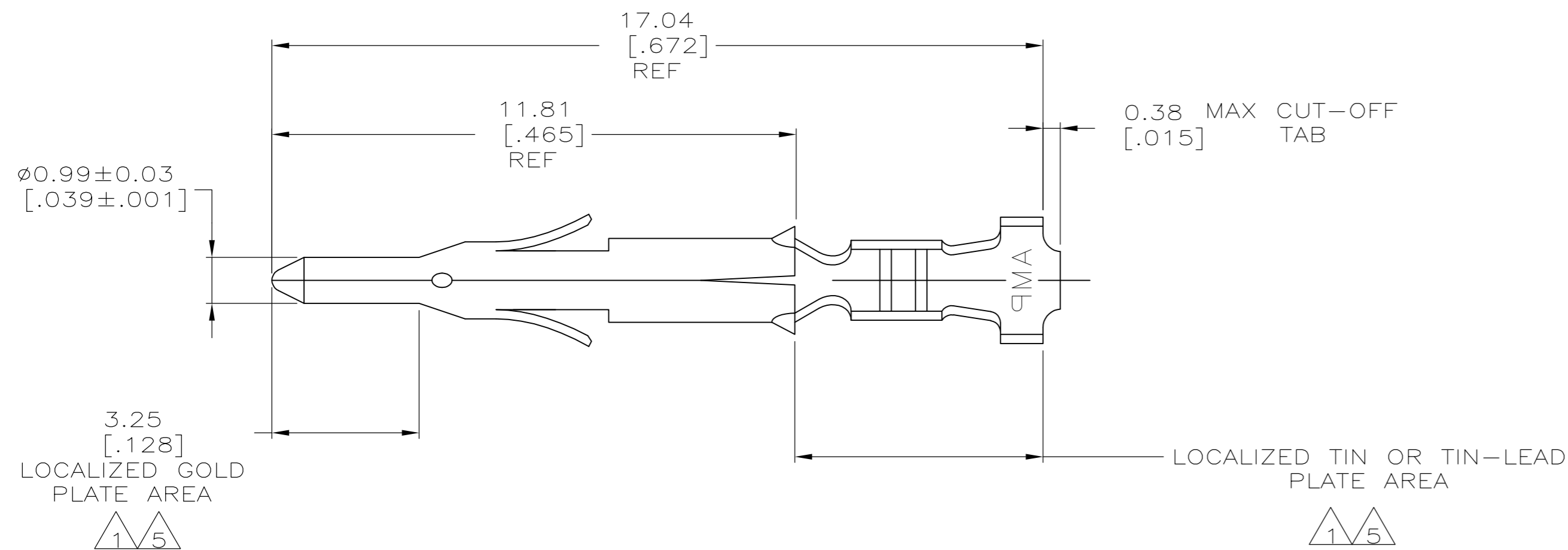

- 1. 0.00076 [.000030] MIN GOLD IN LOCALIZED GOLD PLATE AREA AND 0.00254 [.000100] MIN BRIGHT TIN-LEAD IN LOCALIZED TIN-LEAD PLATE AREA OVER 0.0013 [.000050] MIN NICKEL.
- 2. WIRE RANGE: 0.12 - 0.4mm² (26-22 AWG).
- 3. INSULATION RANGE: 1.20-1.75 [.047-.069] DIA.
- 4. DIMENSIONS IN BRACKETS ARE IN INCHES.
- 5. 0.00076 [.000030] MIN GOLD IN LOCALIZED GOLD PLATE AREA AND 0.00254 [.000100] MIN BRIGHT TIN IN LOCALIZED TIN PLATE AREA OVER 0.0013 [.000050] MIN NICKEL.

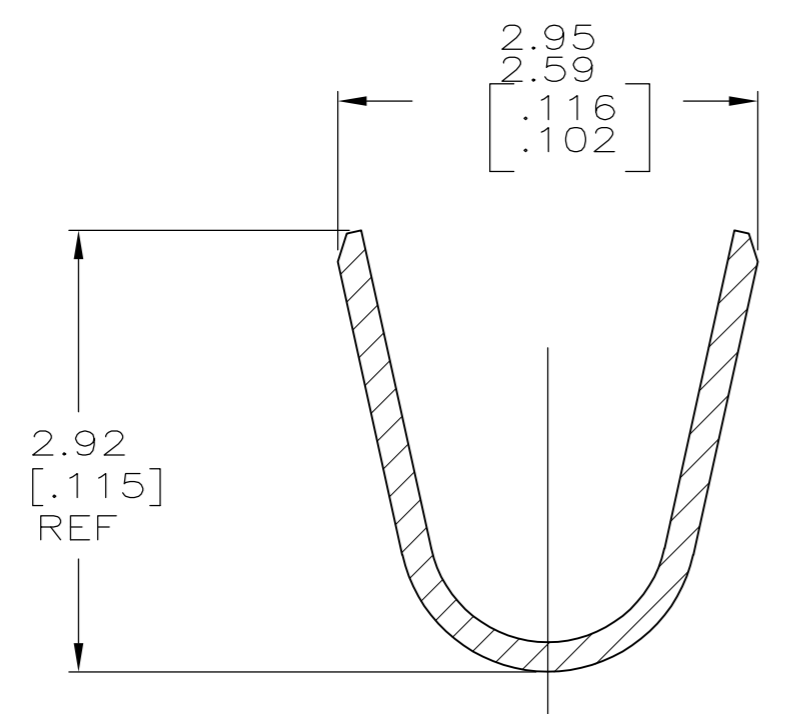
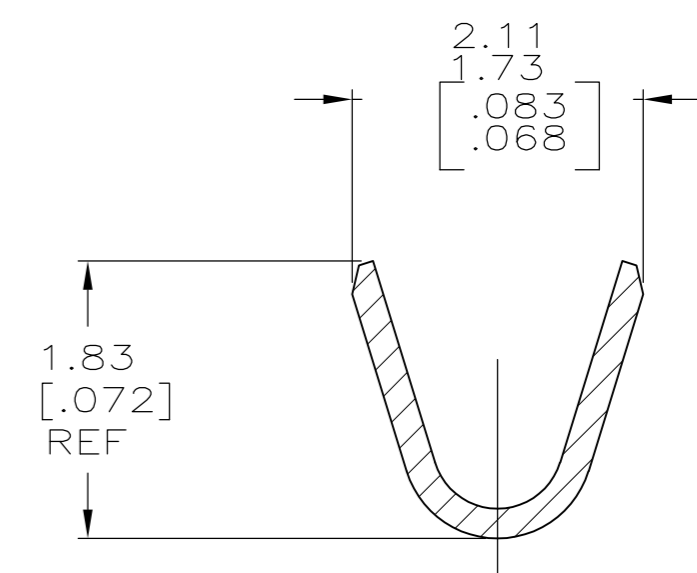
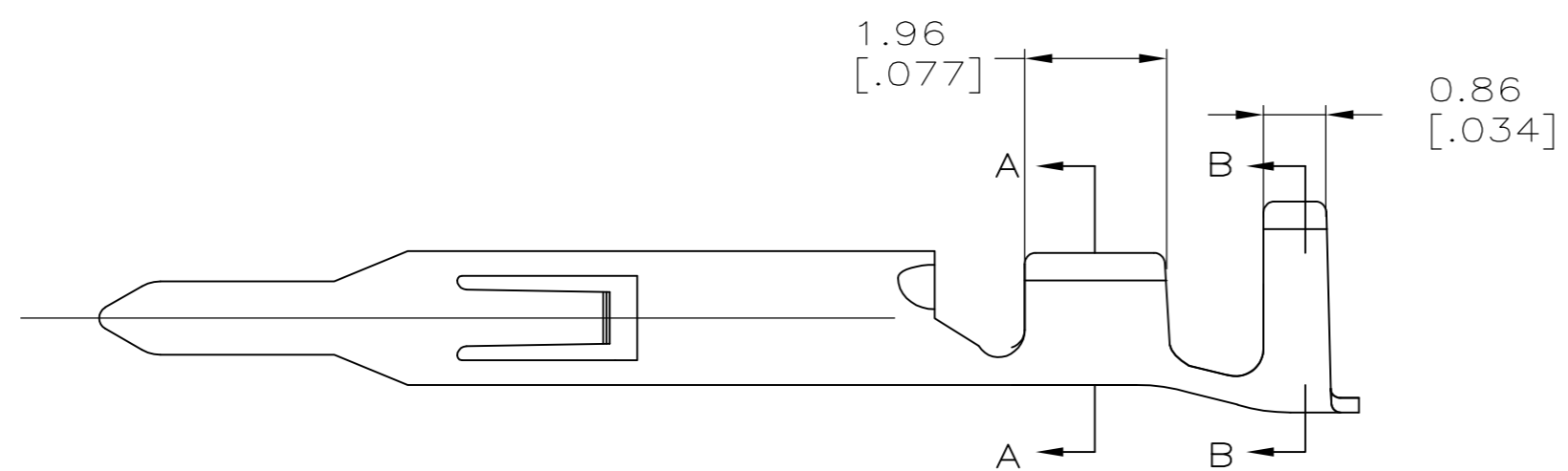

5	0.20 [.008] BRASS	1-770985-0
1	0.20 [.008] BRASS	770985-3
PRE-TIN	0.20 [.008] BRASS	770985-1
FINISH	MATERIAL	PART NUMBER

THIS DRAWING IS A CONTROLLED DOCUMENT.

DIMENSIONS: mm [INCHES]	TOLERANCES UNLESS OTHERWISE SPECIFIED:	DWN S. HOOVER 05MAR03				
	0 PLC ± -	CHK C. JONES 05MAR03				
	1 PLC ± -	APVD C. JONES 05MAR03				
	2 PLC ± 0.13[.005]	PRODUCT SPEC				
	3 PLC ± -	APPLICATION SPEC				
MATERIAL	FINISH	WEIGHT	SIZE A2	CAGE CODE 00779	DRAWING NO. 770985	RESTRICTED TO
		CUSTOMER DRAWING	SCALE 10:1	SHEET 1 of 1	REV G1	

